



VARIAN

vacuum technologies

DS102 1Ph

DS202 1Ph

DS302 1Ph

DS402 1Ph

DS402 3Ph

DS602 1Ph

DS602 3Ph

***Dual Stage Rotary
Vane Pumps***

Model 949-9315

Model 949-9320

Model 949-9325

Model 949-9330

Model 949-9331

Model 949-9335

Model 949-9336

(I) MANUALE DI ISTRUZIONI

(D) BEDIENUNGSHANDBUCH

(F) NOTICE DE MODE D'EMPLOI

(GB) INSTRUCTION MANUAL

DS102 – DS202 – DS302
DS402 – DS602





VARIAN
vacuum technologies

Dear Customer,

Thank you for purchasing a VARIAN vacuum product. At VARIAN Vacuum Technologies we make every effort to ensure that you will be satisfied with the product and/or service you have purchased.

As part of our Continuous Improvement effort, we ask that you report to us any problem you may have had with the purchase or operation of our product. On the back side you find a Corrective Action Request form that you may fill out in the first part and return to us.

This form is intended to supplement normal lines of communications and to resolve problems that existing systems are not addressing in an adequate or timely manner.

Upon receipt of your Corrective Action Request we will determine the Root Cause of the problem and take the necessary actions to eliminate it. You will be contacted by one of our employees who will review the problem with you and update you, with the second part of the same form, on our actions.

Your business is very important to us. Please, take the time and let us know how we can improve.

Sincerely,

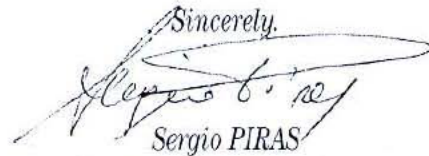

Sergio PIRAS

*Vice President and General Manager
VARIAN Vacuum Technologies*

Note: Fax or mail the Customer Request for Action (see backside page) to VARIAN Vacuum Technologies (Torino) - Quality Assurance or to your nearest VARIAN representative for onward transmission to the same address.

CUSTOMER REQUEST FOR CORRECTIVE / PREVENTIVE / IMPROVEMENT ACTION

TO : VARIAN VACUUM TECHNOLOGIES TORINO - QUALITY ASSURANCE

FAX N° : XXXX - 011 - 9979350

ADDRESS: VARIAN S.p.A. - Via F.lli Varian, 54 - 10040 Leinì (Torino) - Italy



E-MAIL : marco.marzio@varianinc.com

NAME _____	COMPANY _____	FUNCTION _____
<p>ADDRESS : _____</p> <p>TEL. N° : _____ FAX N° : _____</p> <p>E-MAIL : _____</p>		
<p>PROBLEM / SUGGESTION :</p> <p>_____</p> <p>_____</p> <p>_____</p> <p>_____</p>		
<p>REFERENCE INFORMATION (model n°, serial n°, ordering information, time to failure after installation, etc.) :</p> <p>_____</p> <p>_____</p> <p>_____</p> <p style="text-align: right;">DATE _____</p>		

<p>CORRECTIVE ACTION PLAN / ACTUATION (by VARIAN VTT)</p> <p>_____</p> <p>_____</p> <p>_____</p> <p>_____</p> <p>_____</p>	<p>LOG N° _____</p>
--	---------------------

XXXX = Code for dialing Italy from your country (es. 01139 from USA; 00139 from Japan, etc.)



ISTRUZIONI PER L'USO	1
GEBRAUCHSANLEITUNG	3
MODE D'EMPLOI	5
INSTRUCTIONS FOR USE	7
TECHNICAL INFORMATION	9
SECTION I	9
TECHNICAL DESCRIPTION	9
LUBRICATION	9
VACUUM SEALS	10
GAS BALLAST VALVE	10
ANTI-SUCKBACK DEVICE	10
TECHNICAL DATA	14
DIMENSIONS	15
SAFETY PRECAUTIONS	17
TRANSPORT AND INSTALLATION	17
PRELIMINARY OPERATIONS	17
SECTION II	18
ELECTRICAL MOTORS	18
Single phase universal motors	18
Three phase universal motors	20
CONNECTIONS TO THE INLET AND EXHAUST FLANGES	21
STARTING AND RUNNING THE PUMP	21
STOPPING THE PUMP	22
SAFETY RULES	22
WARNING NOTES 	22
CAUTION NOTES 	23
MAINTENANCE ACTIONS	23
LUBRICANTS	24
SCHEDULED MAINTENANCE CARDS	26
UNSCHEDULED MAINTENANCE CARDS	31
TROUBLESHOOTING AND CORRECTIVE ACTION	61
SPARE PARTS LIST	63

INFORMAZIONI GENERALI

Questa apparecchiatura è destinata ad uso professionale. L'utilizzatore deve leggere attentamente il presente manuale di istruzioni ed ogni altra informazione aggiuntiva fornita dalla Varian prima dell'utilizzo dell'apparecchiatura. La Varian si ritiene sollevata da eventuali responsabilità dovute all'inosservanza totale o parziale delle istruzioni, ad uso improprio da parte di personale non addestrato, ad interventi non autorizzati o ad uso contrario alle normative nazionali specifiche.

Le pompe DS102 1Ph, DS202 1Ph, DS302 1Ph, DS402 1Ph, DS402 3Ph, DS602 1Ph e DS602 3Ph sono delle pompe rotative bistadio a palette, a tenuta in bagno d'olio, azionate da motore elettrico mono o trifase.

Queste pompe da alto vuoto sono adatte al pompaggio di gas non corrosivi.

Nei paragrafi seguenti sono riportate tutte le informazioni necessarie a garantire la sicurezza dell'operatore durante l'utilizzo dell'apparecchiatura. Informazioni dettagliate sono fornite nell'appendice "Technical information".

Questo manuale utilizza le seguenti convenzioni:



PERICOLO!

I messaggi di pericolo attirano l'attenzione dell'operatore su una procedura o una pratica specifica che, se non eseguita in modo corretto, potrebbe provocare gravi lesioni personali.



ATTENZIONE!

I messaggi di attenzione sono visualizzati prima di procedure che, se non osservate, potrebbero causare danni all'apparecchiatura.

NOTA

Le note contengono informazioni importanti estrapolate dal testo.

IMMAGAZZINAMENTO

Durante il trasporto e l'immagazzinamento delle pompe non devono essere superate le seguenti condizioni ambientali:

- temperatura: da -20 °C a +70 °C
- umidità relativa: 0 - 95% (non condensante)

PREPARAZIONE PER L'INSTALLAZIONE

La pompa viene fornita in un imballo protettivo speciale; se si presentano segni di danni, che potrebbero essersi verificati durante il trasporto, contattare l'ufficio vendite locale.

Il peso dell'imballo, comprensivo della pompa, è, al massimo, di circa 32 [Kg].

Durante l'operazione di disimballaggio, prestare particolare attenzione a non lasciar cadere la pompa e a non sottoporla ad urti o vibrazioni.

Non disperdere l'imballo nell'ambiente. Il materiale è completamente riciclabile e risponde alla direttiva CEE 85/399 per la tutela dell'ambiente.

NOTA

La pompa non può essere danneggiata rimanendo semplicemente esposta all'atmosfera. Si consiglia comunque di mantenerla chiusa fino al momento dell'installazione sul sistema onde evitare eventuale inquinamento da polvere.

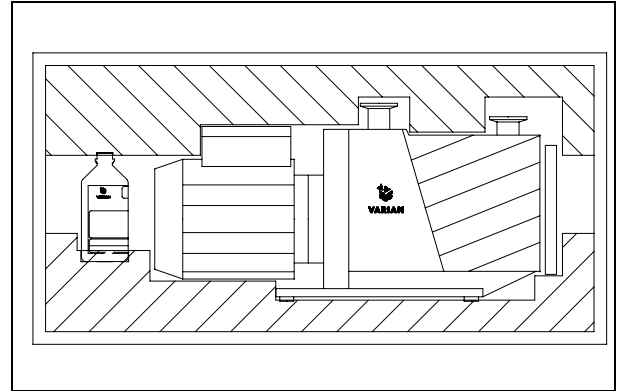

INSTALLAZIONE

Non installare e/o utilizzare la pompa in ambienti esposti ad agenti atmosferici (pioggia, gelo, neve), polveri, gas aggressivi, in ambienti esplosivi o con elevato rischio di incendio.

Durante il funzionamento è necessario che siano rispettate le seguenti condizioni ambientali:

- temperatura: da +12 °C a +40 °C
- umidità relativa: 0 - 95% (non condensante).



PERICOLO!

Per proteggere contro corto-circuiti o sovraccarichi, si deve installare un interruttore automatico sulla linea d'alimentazione principale verso i dispositivi Varian, di capacità adeguata (vedere la tabella seguente):

P/N	110 Vac	220 Vac	380 Vac
949-9315	10 A	6 A	
949-9320	10 A	6 A	
949-9325	10 A	6 A	
949-9330	16 A	7.5 A	
949-9331		6 A	6 A
949-9335	16 A	7.5 A	
949-9336		6 A	4 A



ATTENZIONE!

Prima di avviare la pompa, occorre procedere al rifornimento di olio lubrificante, poiché la pompa viene fornita scarica.



PERICOLO!

Togliere i tappi di protezione posti sulle flange di aspirazione e scarico prima di ogni successiva operazione. L'aria contenuta all'interno della pompa, in caso di accensione involontaria, può proiettarla contro l'operatore.



PERICOLO!

Durante l'installazione prestare la massima attenzione che la flangia di aspirazione sia collegata alla camera da evacuare e che la flangia di scarico non sia tappata (vedere la figura seguente).

La pompa non deve essere usata come compressore.

La massima pressione interna al contenitore dell'olio non deve superare 1,5 bar (abs).

L'inosservanza di queste precauzioni può causare danni alla macchina ed all'operatore.

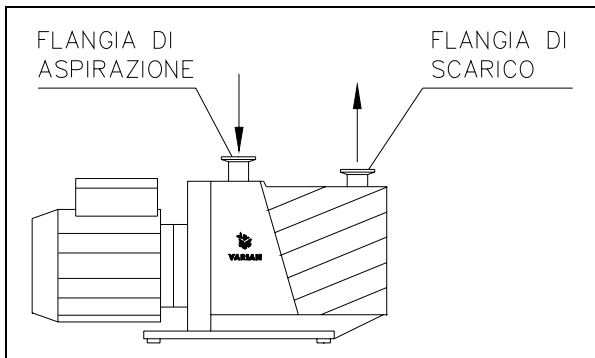

ATTENZIONE!

Controllare che la tensione di alimentazione corrisponda a quella indicata sul cartellino del motore.

Collegare la pompa all'alimentazione.

ATTENZIONE!

Nel caso di motore trifase, una inversione di polarità provoca l'inversione del verso di rotazione della pompa, con conseguenti possibili danni di natura meccanica.

USO

Prima di mettere la pompa in servizio effettivo è necessario, per il raggiungimento del vuoto limite, far marciare per circa un'ora la pompa con zavorra aperta allo scopo di eliminare l'umidità nell'olio.

L'accensione della pompa non richiede particolari manovre; è sufficiente collegarla all'alimentazione elettrica agendo sull'interruttore bipolare (versione con motore monofase) o onnipolare (versione con motore trifase).

PERICOLO!

La pompa è progettata per operare con fluidi neutri o non corrosivi. È assolutamente vietato l'impiego con sostanze potenzialmente esplosive o infiammabili.

Lo spegnimento della pompa non richiede particolari manovre; è sufficiente scollegarla dall'alimentazione elettrica agendo sull'interruttore bipolare (versione con motore monofase) o onnipolare (versione con motore trifase).

MANUTENZIONE

Il personale addetto alla condotta ed alla manutenzione della pompa deve essere ben addestrato e deve avere un'approfondita conoscenza delle norme antinfortunistiche.

PERICOLO!

Le alte tensioni possono causare morte al contatto. Operare sempre con la massima cautela e secondo le norme antinfortunistiche in vigore.

PERICOLO!

Quando la macchina è alimentata prestare attenzione per la presenza di parti in movimento e di alta tensione.

PERICOLO!

Nel caso si debba procedere ad operazioni di manutenzione della pompa al termine di un periodo di esercizio, è necessario lasciarla raffreddare, poiché la temperatura esterna può superare i 60 °C.

PERICOLO!

Escludere sempre l'alimentazione della pompa prima di compiere operazioni di manutenzione. Apporre specifici cartelli di avvertenza: APPARECCHIATURA IN MANUTENZIONE - NON INSERIRE L'ALIMENTAZIONE, in corrispondenza dell'interruttore di alimentazione. Al termine ripristinare i dispositivi di sicurezza.

PERICOLO!

Non effettuare la sostituzione dell'olio subito dopo l'arresto della macchina, in quanto la temperatura dello stesso può essere elevata.

ATTENZIONE!

In fase di sostituzione di pezzi, operare con attenzione. In particolare nel caso di adozione di motore trifase, una inversione di polarità provoca l'inversione del verso di rotazione della pompa, con conseguenti possibili danni di natura meccanica.

NOTA

Prima di rispedire al costruttore una pompa per riparazioni è indispensabile compilare e far pervenire al locale ufficio vendite la scheda "Sicurezza e Salute" allegata al presente manuale di istruzioni. Copia della stessa deve essere inserita nell'imballo della pompa prima della spedizione.

Qualora una pompa dovesse essere rottamata, procedere alla sua eliminazione nel rispetto delle normative nazionali specifiche.

SMALTIMENTO

Significato del logo "WEEE" presente sulle etichette

Il simbolo qui sotto riportato applicato in ottemperanza alla direttiva CE denominata "WEEE".

Questo simbolo (**valido solo per i paesi della Comunità Europea**) indica che il prodotto sul quale è applicato, NON deve essere smaltito insieme ai comuni rifiuti domestici o industriali, ma deve essere avviato ad un sistema di raccolta differenziata.

Si invita pertanto l'utente finale a contattare il fornitore del dispositivo, sia esso la casa madre o un rivenditore, per avviare il processo di raccolta e smaltimento, dopo opportuna verifica dei termini e condizioni contrattuali di vendita.

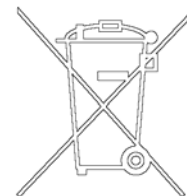

ALLGEMEINE HINWEISE

Dieses Gerät ist für den professionellen Gebrauch bestimmt. Vor dem Gebrauch soll der Benutzer dieses Handbuch sowie alle weiteren von Varian mitgelieferten Zusatzinformationen genau lesen. Bei vollständiger bzw. teilweiser Nichtbeachtung der enthaltenen Hinweise, unsachgemäßem Gebrauch durch ungeschultes Personal, nicht autorisierten Eingriffen und Benutzung unter Mißachtung der nationalen Bestimmungen übernimmt Firma Varian keinerlei Haftung.

Die Pumpen DS102 1Ph, DS202 1Ph, DS302 1Ph, DS402 1Ph, DS402 3Ph, DS602 1Ph und DS602 3Ph sind dichte ölbadeschmierte zweistufige Flügelzellenpumpen, die von einem Ein- oder Dreiphasenstrommotor betätigt werden.

Diese Hochvakuumpumpen eignen sich für das Pumpen von nicht korrosiven Gasen.

In den folgenden Abschnitten sind alle erforderlichen Informationen für die Sicherheit des Bedieners bei der Verwendung des Geräts aufgeführt. Detaillierte technische Informationen sind im Anhang "Technical Information" enthalten.

In dieser Gebrauchsanleitung werden Sicherheitshinweise folgendermaßen hervorgehoben:



GEFAHR!

Die Gefahrenhinweise richten die Aufmerksamkeit des Bedieners auf eine spezielle Prozedur oder Praktik, die bei unkorrekter Ausführung schwere Personenschäden zur Folge haben könnte.



ACHTUNG!

Die Warnhinweise vor bestimmten Prozeduren machen den Bediener darauf aufmerksam, daß bei Nichteinhaltung Schäden am Gerät entstehen können.

ANMERKUNG

Die Anmerkungen enthalten wichtige Informationen, die aus dem Text hervorgehoben werden.

LAGERUNG

Während des Transports und der Lagerung der Pumpen sollen die folgenden Umgebungsbedingungen gegeben sein:

- Temperatur: -20 °C bis +70 °C
- Relative Feuchtigkeit: 0 - 95% (niederschlagsfrei)

VOR DER INSTALLATION

Die Pumpe wird in einer speziellen Schutzverpackung geliefert. Eventuelle Transportschäden sind der zuständigen örtlichen Verkaufsstelle zu melden.

Das Verpackungsgewicht beträgt, einschließlich der Pumpe, maximal 32 Kg.

Beim Auspacken ist darauf zu achten, daß die Pumpe nicht fallengelassen oder Stößen oder Vibrationen ausgesetzt wird.

Das Verpackungsmaterial ist ordnungsgemäß zu entsorgen. Es ist vollständig recyclebar und entspricht der EG-Richtlinie 85/399 für den Umweltschutz.

ANMERKUNG

Die Pumpe kann, wenn sie einfach der Atmosphäre ausgesetzt ist, nicht beschädigt werden. Sie sollte jedoch bis zur Installation an der Anlage geschlossen bleiben, um Verunreinigungen durch Staub zu vermeiden.

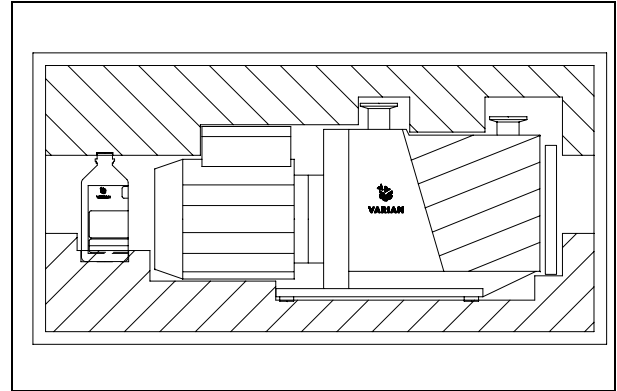

INSTALLATION

Die Pumpe darf nicht in Umgebungen installiert und/oder benutzt werden, die ungeschützt vor Witterungsbedingungen (Regen, Frost, Schnee), Staub und aggressiven Gasen sind und in denen Explosions- oder erhöhte Brandgefahr besteht.

Während des Betriebs sollen die folgenden Umgebungsbedingungen gegeben sein:

- Temperatur: +12 °C bis +40 °C
- Relative Feuchtigkeit: 0 - 95% (niederschlagsfrei).



GEFAHR!

Zum Schutz vor Kurzschlüssen oder Überlastungen, muss ein automatischer Schalter in die Hauptspeisungsleitung zu den Varian-Vorrichtungen installiert werden (siehe folgende Tabelle):

P/N	110 Vac	220 Vac	380 Vac
949-9315	10 A	6 A	
949-9320	10 A	6 A	
949-9325	10 A	6 A	
949-9330	16 A	7.5 A	
949-9331		6 A	6 A
949-9335	16 A	7.5 A	
949-9336		6 A	4 A



ACHTUNG!

Die Pumpe ist vor ihrer Inbetriebnahme mit Schmieröl zu füllen, da sie leer geliefert wird.



GEFAHR!

Vor Aufnahme jeglicher Arbeiten sind die Schutzkappen an den Saug- und Druckflanschen zu entfernen. Die im Pumpeninnern enthaltene Luft könnte diese bei unbeabsichtigter Einschaltung gegen den Bediener schleudern.



GEFAHR!

Bei der Installation ist unbedingt darauf zu achten, dass der Saugflansch an die zu entleerende Kammer angeschlossen ist und der Ablassflansch nicht verschlossen ist (siehe nachstehende Abbildung).

Die Pumpe darf nicht als Verdichter verwendet werden.

Der Druck im Ölbehälter darf nicht größer als 1,5 bar (abs) sein. Bei Nichtbeachtung dieser Anweisungen besteht Schadensgefahr für das Gerät und die Bedienperson.

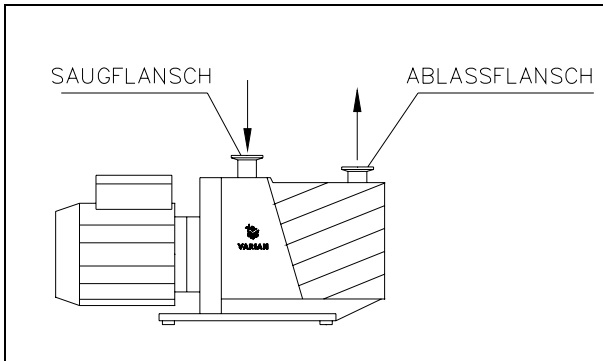

⚠️ ACHTUNG!

Kontrollieren, daß die Versorgungsspannung mit der Spannungsangabe auf dem Typenschild des Motors übereinstimmt.

Die Pumpe an das Versorgungsnetz anschließen.

⚠️ ACHTUNG!

Bei Dreiphasenstrommotoren bewirkt eine Polumkehrung die Umkehrung des Drehsinns der Pumpe, was Schäden an der Mechanik zur Folge haben kann.

GEBRAUCH

Vor der eigentlichen Inbetriebnahme der Pumpe ist es zur Erreichung des Grenzvakuums erforderlich, die Pumpe ungefähr eine Stunde mit geöffnetem Ballast laufen zu lassen, um die Feuchtigkeit aus dem Öl zu entfernen.

Die Einschaltung der Pumpe erfordert keine speziellen Schritte, sie braucht nur durch Betätigung des zweipoligen (Version mit Einphasenstrommotor) oder des allpoligen Trennschalters (Version mit Dreiphasenstrommotor) an die elektrische Energieversorgungsquelle angeschlossen werden.

⚠️ GEFAHR!

Die Pumpe ist für den Betrieb mit neutralen und nicht korrosiven Fluiden konzipiert. Der Einsatz mit potentiell explosions- oder feuergefährlichen Substanzen ist streng verboten.

Die Ausschaltung der Pumpe erfordert keine speziellen Schritte, sie braucht nur durch Betätigung des zweipoligen (Version mit Einphasenstrommotor) oder des allpoligen Trennschalters (Version mit Dreiphasenstrommotor) von der elektrischen Energieversorgungsquelle getrennt zu werden.

WARTUNG

Das für den Betrieb und die Wartung zuständige Personal soll geschult sein und über eine solide Kenntnis der Unfallschutzvorschriften verfügen.

⚠️ GEFAHR!

Hochspannungen können bei Kontakt tödliche Folgen haben. Es ist stets mit größter Vorsicht und gemäß der geltenden Unfallschutzvorschriften vorzugehen.

⚠️ GEFAHR!

Bei eingeschaltetem Gerät ist auf Bewegungs- und Hochspannungsteile zu achten.

⚠️ GEFAHR!

Falls die Pumpe im Anschluß an den Betrieb gewartet werden soll, ist abzuwarten, bis sie abgekühlt ist, da ihre Oberfläche eine Temperatur von 60°C überschreiten kann.

⚠️ GEFAHR!

Vor Wartungsarbeiten ist die Pumpe stets energiefrei zu schalten. Am Netzschalter sind spezielle Warnschilder "INSTANDHALTUNG AM GERÄT – NICHT EINSCHALTEN" anzubringen. Nach Abschluß der Arbeiten sind die Sicherheitseinrichtungen wieder zu aktivieren.

⚠️ GEFAHR!

Keine Ölwechsel unmittelbar nach Stillsetzung des Gerätes vornehmen, da die Öltemperatur sehr hoch sein kann.

⚠️ ACHTUNG!

Bei Ersatz von Teilen ist mit Vorsicht vorzugehen. Insbesondere bei der Version mit Dreiphasenstrommotor bewirkt eine Polumkehrung die Umkehrung des Drehsinns der Pumpe, was Schäden an der Mechanik zur Folge haben kann.

ANMERKUNG

Bevor dem Hersteller eine Pumpe zur Reparatur zurückgesandt wird, ist das Formular "Sicherheit und Gesundheit" in der Anlage zum vorliegenden Handbuch auszufüllen und der lokalen Verkaufsstelle zuzustellen. Eine Kopie des Formulars ist der Pumpenverpackung vor dem Versand beizulegen.

Bei eventueller Verschrottung einer Pumpe ist diese entsprechend der einschlägigen nationalen Vorschriften zu entsorgen.

ENTSORGUNG

Bedeutung des "WEEE" Logos auf den Etiketten

Das folgende Symbol ist in Übereinstimmung mit der EU-Richtlinie WEEE (Waste Electrical and Electronic Equipment) angebracht.

Dieses Symbol (**nur in den EU-Ländern gültig**) zeigt an, dass das betreffende Produkt nicht zusammen mit Haushaltsmüll entsorgt werden darf sondern einem speziellen Sammelsystem zugeführt werden muss.

Der Endabnehmer sollte daher den Lieferanten des Geräts - d.h. die Muttergesellschaft oder den Wiederverkäufer - kontaktieren, um den Entsorgungsprozess zu starten, nachdem er die Verkaufsbedingungen geprüft hat.

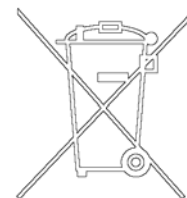

INDICATIONS GÉNÉRALES

Cet appareillage a été conçu en vue d'une utilisation professionnelle. Il est conseillé à l'utilisateur de lire attentivement cette notice d'instructions ainsi que toute autre indication fournie par Varian avant d'utiliser l'appareil. Varian décline par conséquent toute responsabilité en cas de non-respect total ou partiel des instructions fournies, d'utilisation incorrecte de la part d'un personnel non formé, d'opérations non autorisées ou d'un emploi contraire aux réglementations nationales spécifiques.

Les pompes DS102 1Ph, DS202 1Ph, DS302 1Ph, DS402 1Ph, DS402 3Ph, DS602 1Ph e DS602 3Ph sont des pompes rotatives à deux stades à palettes, étanches en bain d'huile, actionnées par un moteur électrique mono ou triphasé.

Ces pompes à vide poussé sont adaptées au pompage de gaz non corrosifs.

Les paragraphes suivants fournissent toutes les indications nécessaires pour garantir la sécurité de l'opérateur pendant l'utilisation de l'appareillage. Des renseignements plus détaillés se trouvent dans l'appendice "Technical information".

Cette notice utilise les signes conventionnels suivants:



DANGER!

Les messages de danger attirent l'attention de l'opérateur sur une procédure ou une manœuvre spéciale dont la mauvaise exécution risque de provoquer de graves lésions.



ATTENTION !

Les messages d'attention apparaissent avant certaines procédures dont le non-respect peut endommager sérieusement l'appareillage.

NOTE

Les notes contiennent des renseignements importants, extrapolés du texte.

EMMAGASINAGE

Pendant le transport et l'emmagasinement des pompes, il faut veiller à respecter les conditions environnementales suivantes :

- température: de -20 °C à +70 °C
- humidité relative: 0 - 95% (non condensante)

PRÉPARATION POUR L'INSTALLATION

La pompe est fournie dans un emballage de protection spécial; si l'on constate des marques de dommages pouvant s'être produits pendant le transport, contacter aussitôt le bureau de vente local.

Le poids total de l'emballage et de la pompe est au maximum de 32 Kg.

Pendant l'opération d'ouverture de l'emballage, veiller tout particulièrement à ne pas laisser tomber la pompe et à ne lui faire subir aucun choc ni aucune vibration

Ne pas jeter l'emballage dans la nature. Le matériel est entièrement recyclable et il est conforme à la directive CEE 85/399 en matière de protection de l'environnement.

NOTE

La pompe ne peut être endommagée en restant simplement exposée à l'atmosphère. Il est de toute façon conseillé de la garder dans son emballage jusqu'au moment de sa mise en fonction afin d'éviter toute pollution due à la poussière

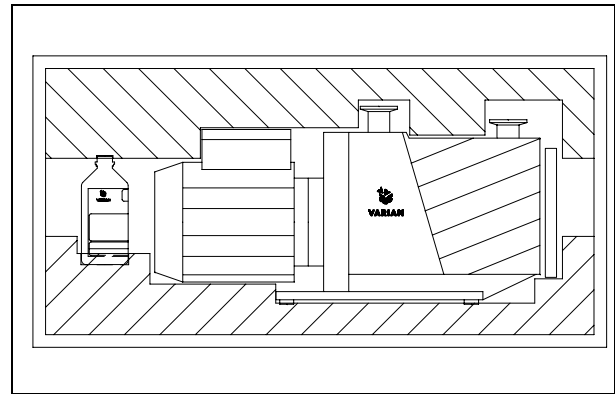

INSTALLATION

Ne pas installer et/ou utiliser la pompe dans des milieux exposés aux agents atmosphériques (pluie, gel, neige), à des poussières, à des gaz agressifs ainsi que dans des milieux explosifs ou à risque élevé d'incendie.

Pendant le fonctionnement, il est nécessaire de respecter les conditions environnementales suivantes :

- Température: de +12 °C à +40 °C
- Humidité relative : 0 - 95% (non condensante).



DANGER!

Pour protéger contre les court-circuits ou les surintensités, il faut installer un disjoncteur automatique sur la ligne d'alimentation principale vers les dispositifs Varian, de bonne capacité (voir tableau ci-dessous):

P/N	110 Vac	220 Vac	380 Vac
949-9315	10 A	6 A	
949-9320	10 A	6 A	
949-9325	10 A	6 A	
949-9330	16 A	7.5 A	
949-9331		6 A	6 A
949-9335	16 A	7.5 A	
949-9336		6 A	4 A



ATTENTION !

Avant toute utilisation de la pompe, il est impératif de procéder à son remplissage en huile de lubrification car elle est livrée vide.



DANGER!

Avant toute autre opération, retirer les bouchons de protection placés sur les brides d'aspiration et de vidange. En cas de mise en marche inopinée de l'appareillage, l'air contenu à l'intérieur de la pompe peut les projeter contre l'opérateur.



DANGER!

Pendant l'installation, faire très attention que la bride d'aspiration soit reliée à la chambre à vider et que la bride d'évacuation ne soit pas bouchée (voir la figure ci-après).

La pompe ne doit pas être utilisée comme un compresseur.

La pression maximale à l'intérieur du réservoir d'huile ne doit pas dépasser 1,5 bar (abs).

Le non-respect de ces précautions peut entraîner un danger pour l'opérateur et l'endommagement de la machine.

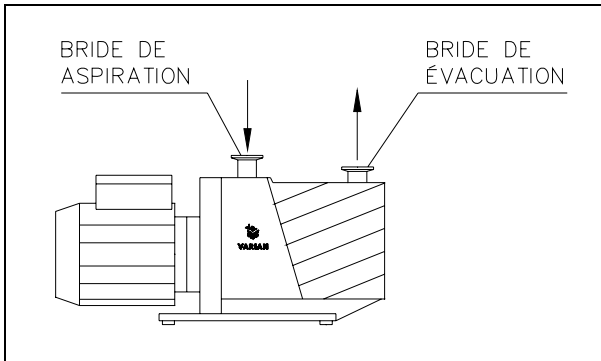

ATTENTION !

Contrôler que la tension d'alimentation correspond à la tension indiquée sur la plaquette du moteur.

Brancher la pompe à la source d'alimentation.

ATTENTION !

En cas de moteur triphasé, une inversion de polarité provoque l'inversion du sens de rotation de la pompe et peut entraîner des dommages de nature mécanique

UTILISATION

Avant la mise en service de la pompe, il est nécessaire, pour atteindre le vide maximum, de faire fonctionner la pompe pendant environ une heure avec le reniflard ouvert afin de supprimer l'humidité de l'huile.

La mise en marche de la pompe ne requiert aucune manœuvre particulière ; il suffit de la brancher à l'alimentation électrique et d'agir sur l'interrupteur bipolaire (version avec moteur monophasé) ou unipolaire (version avec moteur triphasé).

DANGER!

La pompe a été conçue pour fonctionner avec des fluides neutres ou non corrosifs. L'emploi de substances potentiellement explosives ou inflammables est strictement interdit.

L'arrêt de la pompe ne requiert aucune manœuvre particulière ; il suffit de la débrancher de l'alimentation électrique en agissant sur l'interrupteur bipolaire (version avec moteur monophasé) ou unipolaire (version avec moteur triphasé).

MAINTENANCE

Le personnel chargé de la conduite et de la maintenance de la pompe doit avoir reçu la formation nécessaire et posséder une connaissance approfondie des normes de prévention des accidents du travail.

DANGER!

Les hautes tensions peuvent entraîner la mort par contact. Veiller à toujours opérer avec le maximum de prudence et dans le respect des normes de prévention des accidents du travail en vigueur.

DANGER!

Lorsque la machine est sous alimentation, faire attention à la présence d'organes en mouvement et de haute tension.

DANGER!

En cas de nécessité de procéder à des opérations de maintenance de la pompe au terme d'une période de fonctionnement, il est indispensable de la laisser refroidir car sa température extérieure peut être supérieure à 60°C.

DANGER!

Avant toute opération de maintenance, il est impératif de toujours couper l'alimentation de la pompe. Placer les pancartes spécifiques d'avertissement : APPAREILLAGE EN COURS DE MAINTENANCE – NE PAS BRANCHER L'ALIMENTATION, près de l'interrupteur d'alimentation. Au terme des opérations de maintenance, restaurer les dispositifs de sécurité.

DANGER!

Ne pas effectuer la substitution d'huile immédiatement après l'arrêt de la machine car la température de cette dernière peut être élevée.

ATTENTION !

En phase de substitution de pièces, opérer avec le maximum d'attention. En particulier, en cas de moteur triphasé, une inversion de polarité provoque l'inversion du sens de rotation de la pompe et peut entraîner des dommages de nature mécanique.

NOTE

Avant de retourner une pompe au constructeur pour réparation, il est indispensable de remplir et d'adresser au bureau local de vente la fiche "Sécurité et Santé" jointe à la présente notice d'instructions. Une copie de celle-ci devra être mise dans l'emballage de la pompe avant expédition.

En cas de mise au rebut de la pompe, procéder à son élimination conformément aux réglementations nationales en la matière.

MISE AU REBUT

Signification du logo "WEEE" figurant sur les étiquettes

Le symbole ci-dessous est appliqué conformément à la directive CE nommée "WEEE".

Ce symbole (**uniquement valide pour les pays de la Communauté européenne**) indique que le produit sur lequel il est appliqué NE doit PAS être mis au rebut avec les ordures ménagères ou les déchets industriels ordinaires, mais passer par un système de collecte sélective.

Après avoir vérifié les termes et conditions du contrat de vente, l'utilisateur final est donc prié de contacter le fournisseur du dispositif, maison mère ou revendeur, pour mettre en œuvre le processus de collecte et mise au rebut.

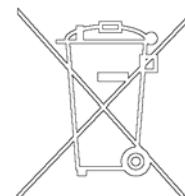

GENERAL INFORMATION

This equipment is destined for use by professionals. The user should read this instruction manual and any other additional information supplied by Varian before operating the equipment. Varian will not be held responsible for any events occurring due to non-compliance, even partial, with these instructions, improper use by untrained persons, non-authorized interference with the equipment or any action contrary to that provided for by specific national standards.

The DS102 1Ph, DS202 1Ph, DS302 1Ph, DS402 1Ph, DS402 3Ph, DS602 1Ph and DS602 3Ph pumps are dual-stage, rotary vane pumps oil sealed, driven by a single-phase or three-phase electric motor.

These high vacuum pumps are suitable for pumping non corrosive gases.

The following paragraphs contain all the information necessary to guarantee the safety of the operator when using the equipment. Detailed information is supplied in the appendix "Technical Information".

This manual uses the following standard protocol:



WARNING!

The warning messages are for attracting the attention of the operator to a particular procedure or practice which, if not followed correctly, could lead to serious injury.



CAUTION

The caution messages are displayed before procedures which, if not followed, could cause damage to the equipment.

NOTE

The notes contain important information taken from the text.

STORAGE

When transporting and storing the pumps, the following environmental requirements should not be exceeded:

- temperature: from -20° to +70 °C
- relative humidity: 0 - 95% (non-condensing)

PREPARATION FOR INSTALLATION

The pump is supplied in a special protective packing. If this shows signs of damage which may have occurred during transport, contact your local sales office.

Total weight of the pack, including the pump, is approx. 32 Kg. When unpacking the pump, be sure not to drop it and avoid any kind of sudden impact or shock vibration to it.

Do not dispose of the packing materials in an unauthorized manner. The material is 100% recyclable and complies with EEC Directive 85/399.

NOTE

Normal exposure to the environment cannot damage the pump. Nevertheless, it is advisable to keep it closed until it is installed in the system, thus preventing any form of pollution by dust.

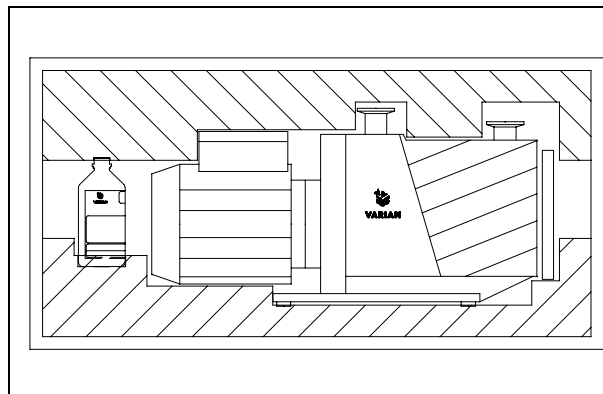

INSTALLATION

Do not install or use the pump in an environment exposed to atmospheric agents (rain, snow, ice), dust, aggressive gases, or in explosive environments or those with a high fire risk. During operation, the following environmental conditions must be respected:

- temperature: from +12 °C to +40 °C
- relative humidity: 0 - 95% (non-condensing)



WARNING!

Protect against short circuits and overload by installing on Varian Device electrical main line an automatic circuit breaker of proper capacity (see table here below):

P/N	110 Vac	220 Vac	380 Vac
949-9315	10 A	6 A	
949-9320	10 A	6 A	
949-9325	10 A	6 A	
949-9330	16 A	7.5 A	
949-9331		6 A	6 A
949-9335	16 A	7.5 A	
949-9336		6 A	4 A



CAUTION

Before starting the pump, fill up with lubricating oil as the pump is delivered empty.



WARNING!

Take out the protective caps on the suction and exhaust flanges before doing anything else. In the event of an accidental start-up, the air inside the pump could violently expel the protective caps and harm the operator.



WARNING!

During installation, pay maximum attention that the suction flange is connected to the vacuum chamber and the exhaust flange is not closed (see the following figure).

The pump must not be used as a compressor. Maximum pressure inside the oil container must not exceed 1.5 bar (abs.)

Non-observance of these precautions may be dangerous for the machine and the operator.

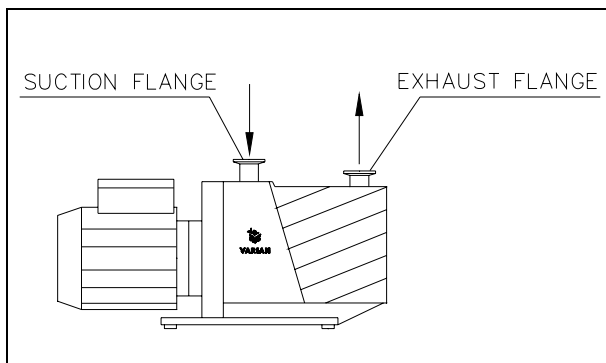

CAUTION

Check that your electrical mains voltage corresponds to that indicated on the motor's plate.

Connect the pump to the power supply.

CAUTION

Pay special attention to the three-phase motor, where an inversion of polarity causes inversion of the direction of rotation of the pump with consequent possibilities of mechanical damage.

USE

Before being put into service, in order to reach maximum vacuum, the pump must be left running for about an hour with the gas ballast valve open. This will eliminate any humidity from the oil.

There are no special procedures for switching the pump on; it needs only to be connected to the electric power by means of the bipolar switch (version with single-phase motor) or of the multipolar switch (version with three-phase motor).

WARNING!

The pump is designed for operation with neutral or non-corrosive fluids. It is absolutely forbidden to use potentially explosive or flammable substances.

There are no special procedures for switching the pump off; it needs only to be disconnected from the electric power by means of the bipolar switch (version with single-phase motor) or of the multipolar switch (version with three-phase motor).

MAINTENANCE

Personnel responsible for pump operation and maintenance must be well-trained and must be aware of the accident prevention rules.

WARNING!

Death may result from contact with high voltages. Always take extreme care and observe the accident prevention regulations in force.

WARNING!

When machine is powered take care on account of moving parts and high voltages.

WARNING!

If you have to perform maintenance on the pump after a considerable time in operation, leave it to cool as temperature of the outer surface may be in excess of 60 °C.

WARNING!

Always disconnect the power supply to the pump before starting maintenance work. Place a special warning signs over the power supply breaker switch: MACHINE UNDERGOING MAINTENANCE - DO NOT POWER ON. When finished, remove the safety warning.

WARNING!

Do not change the oil immediately after stopping the machine as the oil temperature may still be high.

CAUTION

When replacing a part, take great care. Pay special attention to the three-phase motor, where an inversion of polarity causes inversion of the direction of rotation of the pump with consequent possibilities of mechanical damage.

NOTE

Before returning the pump to the constructor for repairs the "Health and Safety" sheet attached to this instruction manual must be filled-in and sent to the local sales office. A copy of the sheet must be inserted in the pump package before shipping.

If a pump is to be scrapped, it must be disposed of in accordance with the specific national standards.

DISPOSAL

Meaning of the "WEEE" logo found in labels

The following symbol is applied in accordance with the EC WEEE (Waste Electrical and Electronic Equipment) Directive. This symbol (**valid only in countries of the European Community**) indicates that the product it applies to must NOT be disposed of together with ordinary domestic or industrial waste but must be sent to a differentiated waste collection system. The end user is therefore invited to contact the supplier of the device, whether the Parent Company or a retailer, to initiate the collection and disposal process after checking the contractual terms and conditions of sale.

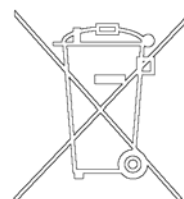

SECTION I

TECHNICAL DESCRIPTION

The DS102 1Ph, DS202 1Ph, DS302 1Ph, DS402 1Ph, DS402 3Ph, DS602 1Ph and DS602 3Ph pumps are dual-stage, rotary vane pumps oil sealed, driven by a single-phase or three-phase electric motor.

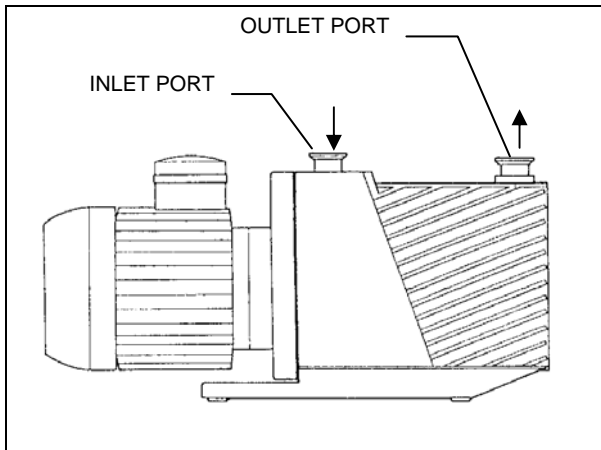

These vacuum pumps are suitable for pumping non corrosive gases.

The main features are:

- all parts in direct contact with the fluid pumped are free of copper alloys;
- all materials are carefully selected to provide extended life;
- a high capacity gas ballast device allow to pump condensable vapors;
- all the parts composing the pump are fully replaceable due to the close machining tolerances and to the centering obtained by using reference pins;
- due to its design features and low number of gaskets, the pump requires little maintenance, disassembly and reassemble are easy and require minimal time.

The pump works with force-feed lubrication, provided by an auxiliary gear-pump driven by the rotor of the vacuum pump itself. This ensures proper lubrication even when pressures are close to atmospheric.

The entire pump functional block is immersed in the oil contained in the casing. The oil guarantees perfect sealing of the discharge valves, enters the pump to ensure lubrication and sealing of the parts inside, facilitates heat dissipation and reduces pump noise.

The pump is equipped with a special anti-suckback device which automatically isolates the vacuum system when the pump stops. This avoids rises in pressure or oil flow in the vacuum system while air is allowed back into the stator chambers.

The air entering the pump after the anti-suckback device has closed prevents the oil in the casing from filling the stator chambers.

The inner seals are achieved by the lubricating oil, thanks to the close machining tolerances.

There is only one oil seal on the rotor shaft, the one preventing oil from seeping out of the pump. This seal acts on a bushing fitted onto the shaft. Simple replacement of this seal grants the rotor a practically unlimited life (pumps DS402 1Ph, DS402 3Ph, DS602 1Ph, DS602 3Ph). On the DS102 1Ph, DS202 1Ph and DS302 1Ph pumps, this seal acts on a surface-hardened area of the shaft guaranteeing long rotor life.

The vacuum pumps are connected directly to the electric motor through a flexible coupling, so that motion is transmitted even in case of poor alignment.

A fan fitted on the joint and housed in the pump support produces a forced air flow over the finned surfaces of the casing to avoid oil overheating.

LUBRICATION

The pump's lubricating system is force-feed type.

Oil circulation is obtained by means of a gear pump connected to the rotor shaft.

The oil is drawn through a gauze filter to prevent any foreign bodies from entering the pump.

Shunt-mounted on the delivery line is a hydraulic piston which, besides actuating the anti-suckback device (see *ANTI-SUCKBACK DEVICE*), also regulates pressure by discharging excess oil flow directly into the tank.

The required flow of oil under pressure passes through ducts that are drilled in the walls of the pump and lubricates the bushings and the inside parts.

VACUUM SEALS

A special feature of this pump is the low number of gaskets that are employed.

The seals in the circuit are obtained by means of VITON gaskets.

The careful surface finish of the various parts of the pump means that vacuum sealing of the functional block is ensured by the film of oil separating metal surfaces. Sealing of the rotor shaft is guaranteed by a rotating gasket with dust-guard lip.

The suction flange and duct are sealed by mean of OR gaskets.

GAS BALLAST VALVE

When the pump sucks in vapors, these condense during compression and mix with the oil, forming an emulsion (an aqueous vapor, for example) or a solution (organic solvent vapors, for example).

A number of problems arise from this, such as the impossibility of obtaining high vacuums, the alteration of the properties of the oil, could cause scaling on parts of the pump.

To avoid this, during compression at the second stage, atmospheric air is let into the pump through an adjustable valve, or "gas ballast valve", located at the top of the pump.

In this way, the discharge valve of the second stage opens through the effect of the atmospheric air before the partial pressure of the vapor reaches saturation point, thus preventing condensation from occurring. The vapors are expelled mixed with air.

ANTI-SUCKBACK DEVICE

The pump is equipped with a special anti-suckback device to avoid air pressure rises and/or oil backflow towards the evacuated vessel when the pump is switched off. This device has a shutter which automatically closes the suction duct.

In this way the pump and vacuum system are completely isolated from each other and air can enter the pump without any risk for the vacuum produced in the system.

The device includes some special features, namely:

- drive obtained avoiding any form of contamination of the inlet duct by fluids (oil and/or air) used to command the shutter. Thanks to this, when the pump is started again, the pump-down to vacuum conditions is extremely fast as these contaminants are not present and no degassing is therefore required;
- suction flange maintained closed even when the pump is idle, so that pollutants cannot enter from the environment and no oil can overflow from the pump.

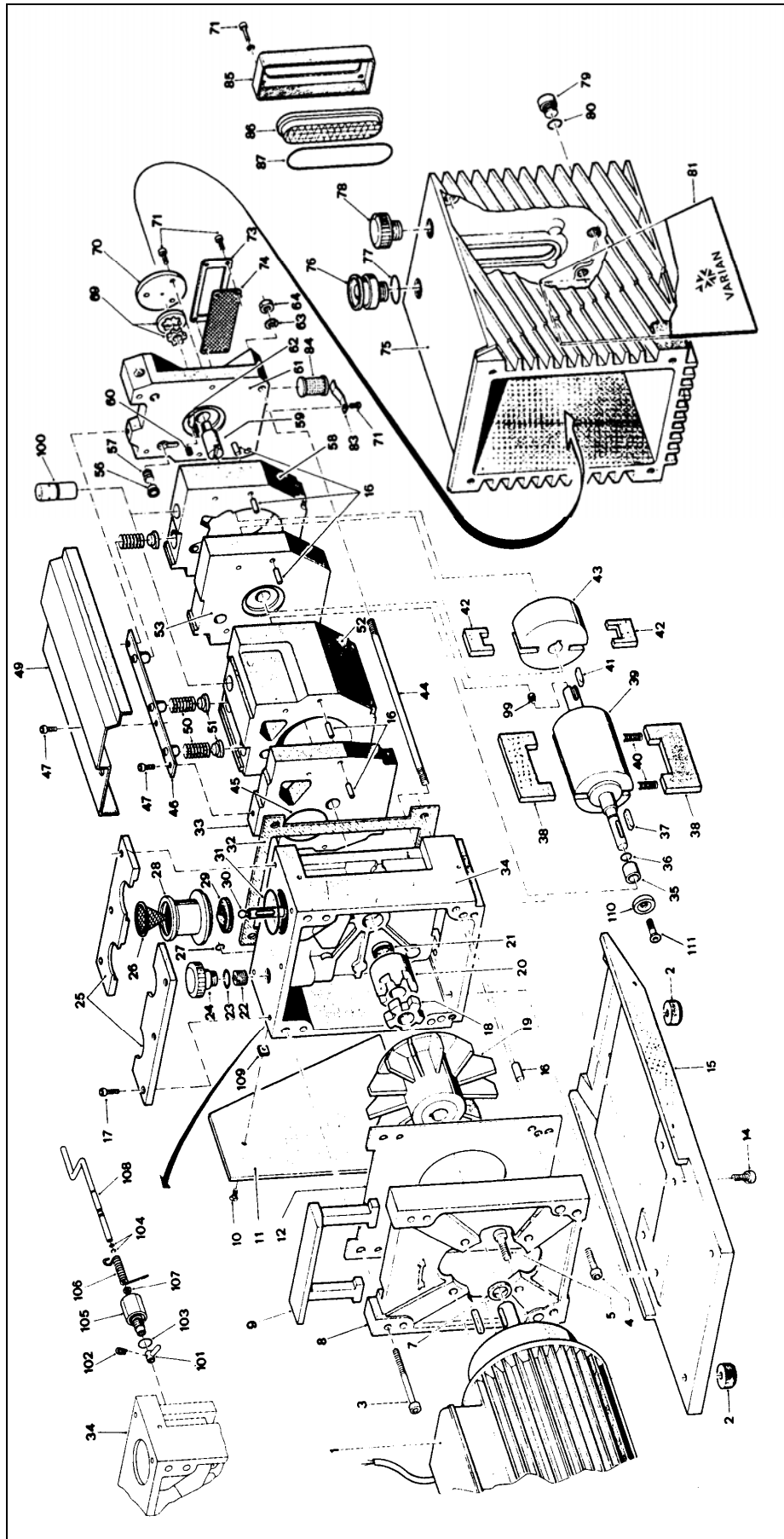

View of the pump

Legend (cf. figure *View of the pump*)

N°	Description	DS 102	DS202	DS302	DS402	DS602
1	Electric motor	SR03700702	SR03700702	SR03700702	SR03700703	SR03700703
1A	Electric motor 370-450W	SR03700865	SR03700865	SR03700865		
1B	Three phase electric motor	SR03700922	SR03700922	SR03700922	SR03700704	SR03700704
2	Rubber foot					
3	Screw					
4	Screw					
5	Screw					
7	Spacer					
8	Motor support					
9	Handle					
10	Screw					
11	Right sideplate					
12	Board					
14	Screw					
15	Support plate					
16	Cylindrical pin	(4) - (1)	(4) - (2)	(4) - (2)	(5) - (3)	(5) - (3)
17	Screw					
18	Rubber crown	(4) - (1)	(4) - (2)	(4) - (2)	(5) - (3)	(5) - (3)
19	Half-joint with fan					
20	Half-joint (pump side)					
21	Oil-seal ring	(4) - (1)	(4) - (2)	(4) - (2)	(5) - (3)	(5) - (3)
22	Special screw					
23	OR gasket	(4) - (1)	(4) - (2)	(4) - (2)	(5) - (3)	(5) - (3)
24	Gas Ballast Valve knob	SR03700219	SR03700219	SR03700219	SR03700219	SR03700219
25	Half-plate					
26	Inlet screen	SR03700237	SR03700237	SR03700237	SR03700237	SR03700237
27	OR gasket	(4) - (1)	(4) - (2)	(4) - (2)	(5) - (3)	(5) - (3)
28	Suction flange					
29	Anti-suckback shutter	(4) - (1)	(4) - (2)	(4) - (2)	(5) - (3)	(5) - (3)
30	Piston					
31	OR gasket	(4) - (1)	(4) - (2)	(4) - (2)	(5) - (3)	(5) - (3)
32	Casing gasket	(4) - (1)	(4) - (2)	(4) - (2)	(5) - (3)	(5) - (3)
33	Inner plate	SR03700260	SR03700260	SR03700260	SR03700362	SR03700362
34	Pump support					
35	Anti-wear bushing				SR03700370	SR03700370
36	OR gasket	(4) - (1)	(4) - (2)	(4) - (2)	(5) - (3)	(5) - (3)
37	Kei motor side	SR8999980101	SR8999980101	SR8999980101	SR8999980301	SR8999980301
38	First stage vane	(1)	(2)	(2)	(3)	(3)
39	First stage rotor	SR03700273	SR03700319	SR03700319	SR03700371	SR03700371
40	Spring	(4) - (1)	(4) - (2)	(4) - (2)	(5) - (3)	(5) - (3)
41	Tongue	SR8999980001	SR8999980001	SR8999980001	SR8999980401	SR8999980401
42	Second stage vane	(1)	(2)	(2)	(3)	(3)
43	Second stage rotor	SR03700269	SR03700269	SR03700269	SR03700367	SR03700367
44	Tie-rod	SR03700209	SR03700308	SR03700308	SR03700335	SR03700335
45	OR gasket	(4) - (1)	(4) - (2)	(4) - (2)	(5) - (3)	(5) - (3)
46	Bracket					
47	Screw					
49	Valve cover plate					
50	Valve spring	(4) - (1)	(4) - (2)	(4) - (2)	(5) - (3)	(5) - (3)

N°	Description	DS 102	DS202	DS302	DS402	DS602
51	Valve gasket	(4) - (1)	(4) - (2)	(4) - (2)	(5) - (3)	(5) - (3)
52	First stage stator	SR03700261	SR03700316	SR03700495	SR03700363	SR03700419
53	Middle plate	SR03700262	SR03700262	SR03700262	SR03700421	SR03700421
56	GasBallast Valve shutter	(4) - (1)	(4) - (2)	(4) - (2)	(5) - (3)	(5) - (3)
57	GasBallast Valve spring	(4) - (1)	(4) - (2)	(4) - (2)	(5) - (3)	(5) - (3)
58	Second stage stator	SR03700321	SR03700321	SR03700321	SR03700364	SR03700364
59	Oil pump joint	SR03700280	SR03700280	SR03700280	SR03700390	SR03700390
60	Special screw					
61	End plate	SR03700285	SR03700285	SR03700285	SR03700391	SR03700391
62	Tongue					
63	Washer					
64	Nut					
69A	External oil pump gear	SR03700281	SR03700281	SR03700281	SR03700281	SR03700281
69B	Internal oil pump gear	SR03700277	SR03700277	SR03700277	SR03700277	SR03700277
70	Oil pump cover					
71	Screw					
73	Plate					
74	Filter					
75	Casing					
76	Exhaust flange					
77	OR gasket	(4) - (1)	(4) - (2)	(4) - (2)	(5) - (3)	(5) - (3)
78	Oil fill plug	03.701218	03.701218	03.701218	03.701218	03.701218
79	Oil drain plug	SR03700256	SR03700256	SR03700256	SR03700256	SR03700256
80	Oil drain plug gasket	SR03700256	SR03700256	SR03700256	SR03700256	SR03700256
81	Left sideplate					
83	Spring					
84	Filter					
85	Flange					
86	Sight glass	03.701326	03.701326	03.701326	03.701326	03.701326
87	OR gasket	(4) - (1)	(4) - (2)	(4) - (2)	(5) - (3)	(5) - (3)
99	Special screw					
100	Piston					
101	Arm					
102	Spring	(1)	(2)	(2)	(3)	(3)
103	OR gasket	(4) - (1)	(4) - (2)	(4) - (2)	(5) - (3)	(5) - (3)
104	OR gasket	(4) - (1)	(4) - (2)	(4) - (2)	(5) - (3)	(5) - (3)
105	Sleeve					
106	Spring	(1)	(2)	(2)	(3)	(3)
107	Ring	(4) - (1)	(4) - (2)	(4) - (2)	(5) - (3)	(5) - (3)
108	Arm					
109	Insert					
110	Special washer					
111	Screw					

NOTES

- (1) Part of DS 102 Major Maintenance Kit (P/N 9499380)
- (2) Part of DS 202-302 Major Maintenance Kit (P/N9499381)
- (3) Part of DS 402-602 Major Maintenance Kit (P/N 9499382)
- (4) Part of DS 102-202-302 Minor Maintenance Kit (P/N 9499370)
- (5) Part of DS 402-602 Minor Maintenance Kit (P/N 9499371)

TECHNICAL DATA

The following table lists the main technical data of the DS102 1Ph, DS202 1Ph, DS302 1Ph, DS402 1Ph, DS402 3Ph, DS602 1Ph and DS602 3Ph pumps.

TECHNICAL DATA	Hz	UNITS	DS102	DS202	DS302	DS402	DS602
FREE AIR DISPLACEMENT	60	l/min (cfm)	114 (4)	192 (6,8)	285 (10)	410 (14,5)	605 (21,4)
	50	l/min (m ³ /h)	95 (5,7)	160 (9,6)	237 (14,2)	342 (20,5)	540 (30,2)
PUMPING SPEED *	60	cfm	3,5	5,8	8,2	12,3	18,3
	50	m ³ /h	5	8,3	11,6	17,4	26
ULTIMATE PARTIAL PRESSURE *		mbar	10 ⁻⁴	10 ⁻⁴	10 ⁻⁴	10 ⁻⁴	10 ⁻⁴
ULTIMATE TOTAL PRESSURE *		mbar	2·10 ⁻³	2·10 ⁻³	2·10 ⁻³	2·10 ⁻³	2·10 ⁻³
ULTIMATE TOTAL PRESSURE WITH GAS BALLAST *		mbar	2·10 ⁻²	2·10 ⁻²	2·10 ⁻²	1·10 ⁻²	1·10 ⁻²
WATER VAPOR TOLERANCE		mbar	15	15	20	30	30
WATER VAPOR CAPACITY		g/h	60	100	160	350	550
OIL CAPACITY min/max		l	0,3/0,5	0,4/0,6	0,4/0,6	0,6/1	0,6/1
MOTOR RATING 1ph	50/60	kW	0,45/0,55	0,45/0,55	0,45/0,55	0,75/0,90	0,75/0,90
MOTOR RATING 3ph	50/60	kW				0,75/0,90	0,75/0,90
NOMINAL ROTATION SPEED	50	rpm	1500	1500	1500	1500	1500
	60	rpm	1800	1800	1800	1800	1800
OIL TEMPERATURE (pump operating) **		°C	50	50	52	70	72
		°F	122	122	126	158	162
Installation category	II						
Pollution degree	2						
OPERATING TEMPERATURE RANGE		°C	12 - 40	12 - 40	12 - 40	12 - 40	12 - 40
WEIGHT		Kg	22	24	24	36	36
		lb	48	53	53	79	79
INLET FLANGE		DN	25KF	25KF	25KF	25KF	25KF
EXHAUST FLANGE		DN	25KF	25KF	25KF	25KF	25KF
Dimensions (cf. also next table):							
- length, 1ph		mm	454	491	491	530	530
- width		mm	134	134	134	164	164
- height		mm	212	212	212	242	242
Input single phase versions ***							
Nominal voltages:	50	V	$\frac{100}{200-240}$	$\frac{100}{200-240}$	$\frac{100}{200-240}$	$\frac{100}{200-240}$	$\frac{100}{200-240}$
	60	V	$\frac{100-120}{200-230}$	$\frac{100-120}{200-230}$	$\frac{100-120}{200-230}$	$\frac{100-120}{200-230}$	$\frac{100-120}{200-230}$
Maximum currents:	50	A	$\frac{8,8}{5,4}$	$\frac{8,8}{5,4}$	$\frac{8,8}{5,4}$	$\frac{11,8}{6,2}$	$\frac{11,8}{6,2}$
	60	A	$\frac{8,8}{4,4}$	$\frac{8,8}{4,4}$	$\frac{8,8}{4,4}$	$\frac{12,8}{6,4}$	$\frac{1,8}{6,4}$

* According to PNEUROP 6602

** At ultimate total pressure, 20 °C (68 °F) room temperature

*** For more details about the electrical motors see pages from 17 to 20

DIMENSIONS

MODEL	UNITS	A	B	C	D	H	L	M	N	P	R	W
DS102	mm	30	30	35	3	212	430	250	100	105	165	132
	inch	1,18	1,18	1,38	0,12	8,3	16,9	9,8	3,9	4,1	6,5	5,2
DS202	mm	30	30	35	3	212	467	250	100	105	205	132
	inch	1,18	1,18	1,38	0,12	8,3	18,4	9,8	3,9	4,1	8,1	5,2
DS302	mm	30	30	35	3	212	467	250	100	105	205	132
	inch	1,18	1,18	1,38	0,12	8,3	18,4	9,8	3,9	4,1	8,1	5,2
DS402	mm	40	40	40	6	242	541	261	130	100	230	164
	inch	1,57	1,57	1,57	0,24	9,5	21,3	10,3	5,1	3,9	9,1	6,5
DS602	mm	40	40	40	6	242	541	261	130	100	230	164
	inch	1,57	1,57	1,57	0,24	9,5	21,3	10,3	5,1	3,9	9,1	6,5

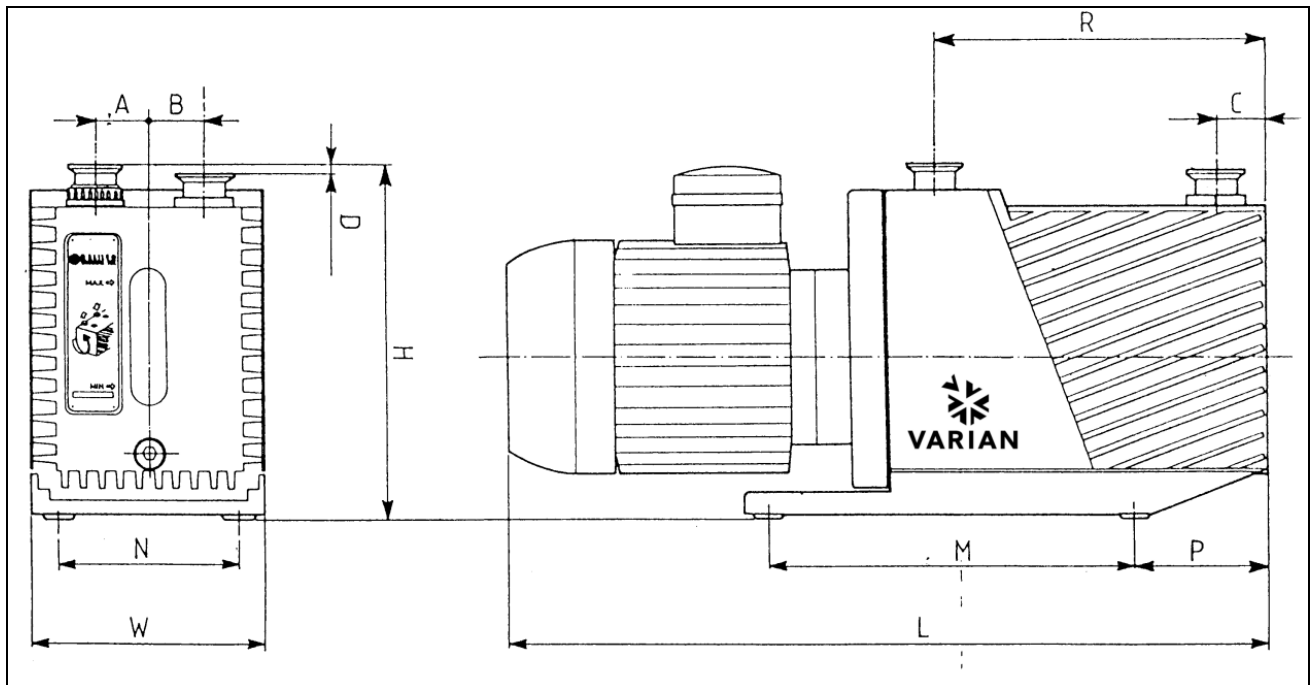

Pump dimensions

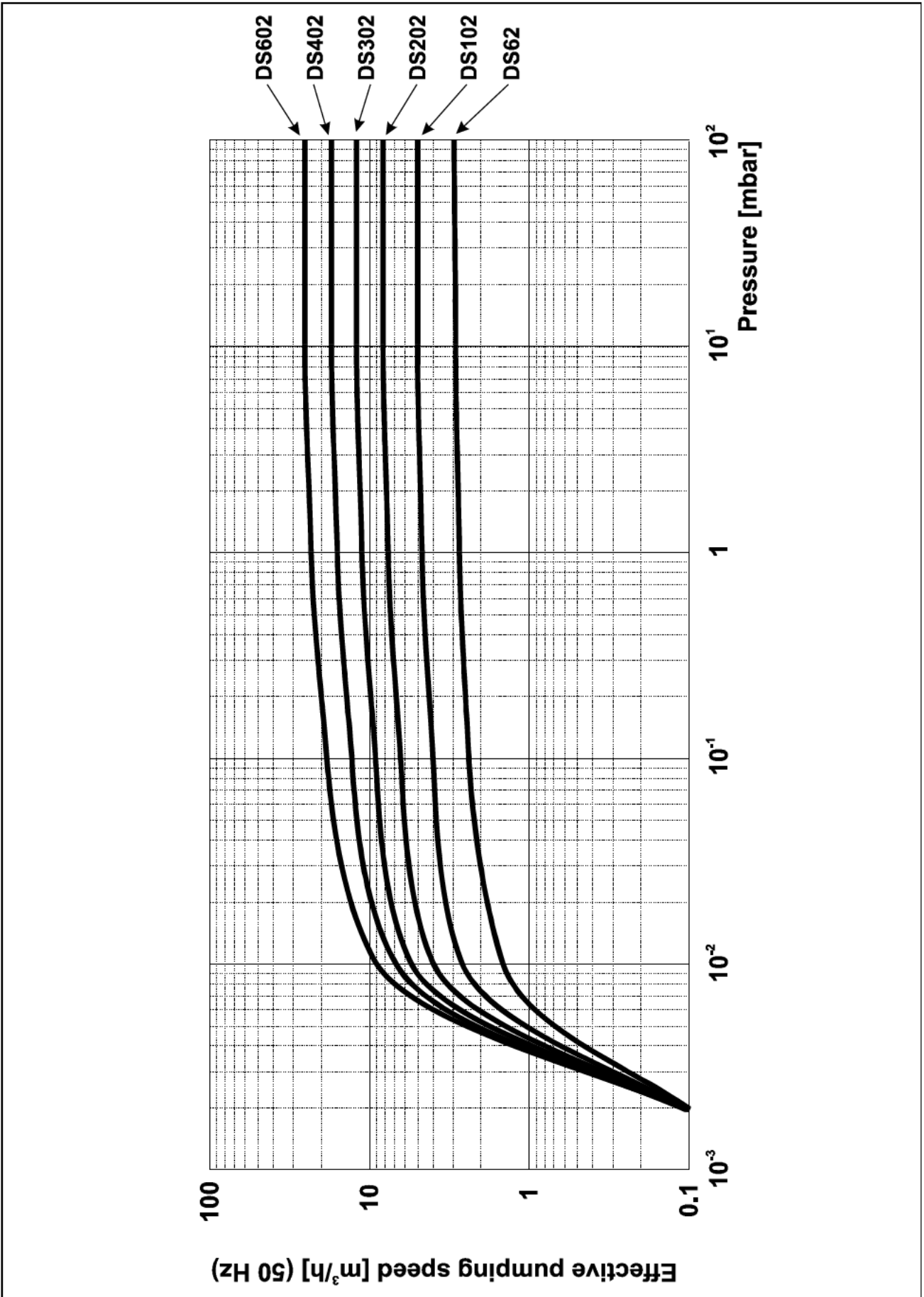

Typical Performance Curves

SAFETY PRECAUTIONS

- Always carry the pump by means of the handles provided.
- The pump must be set in position taking the upmost care in order to avoid accidental falls.



WARNING!

In case of a need to handle the pump after a period of operation, it must be left to cool first as the external surface temperature may be in excess of 60 °C.

TRANSPORT AND INSTALLATION

The pumps are shipped to the customer inside cardboard boxes.

Total weight of the pack, including the pump, is between 30 Kg. and 40 Kg. according to the different pump models.

The case must be handled with care, using appropriate lifting equipment.



CAUTION

When moving the case, ensure that it is securely bound to the lifting equipment and that the equipment is strong enough to support the weight.

The pump's working environment is a traditional industrial environment. Naturally sites with corrosive vapors or excessive heat are best avoided.

Room temperature should ideally be between 12 °C and 40 °C.

If the temperature is not inside this range, consult Varian technical service for the changes required.

Setting the pump in position should be performed as follows:

- Pump laid on the ground. There are no special instructions for this type of installation, except that the floor should be as flat as possible and suited to bear the weight of the pump (it should ideally be a concrete floor) and of any accessories mounted on it. Note that the pump is stable on its base plate and it should not be necessary to anchor it to the floor with bolts and screws; also vibrations to and from the pump are greatly reduced by the use of rubber feet.

- Pump off the ground. In this case, the user must design a suitable support structure, remembering the following points:
 - * the plane supporting the pump must be perfectly horizontal;
 - * the structure should be adequately rigid;
 - * the relevant safety precautions should be applied.

Note also that the pump should be attached to the supporting structure after replacing the rubber feet with special anti-vibration feet, which should be screwed to the pump base and to the supporting plane.

After taking the pump out of its packing case, you are advised to make the following checks:

- a. Ensure that the pump has not suffered any damage during shipping.
- b. Check that the guards are mounted correctly (side plates, refs. 11 and 81 in fig. *View of the pump*) and that there are no uncovered or loose parts.

PRELIMINARY OPERATIONS

Before starting the pump, fill up with lubricating oil as the pumps are delivered empty.

NOTE

A tin of oil is included in the packing.

For details on how to fill up, see Scheduled Maintenance Card 01.



CAUTION

Oil must be poured into the casing through the special threaded plughole and NOT through the suction line.



WARNING!

Take out the protective caps on the suction and exhaust flanges before doing anything else. In the event of an accidental start-up, the air inside the pump could violently expel the protective caps and harm the operator.

SECTION II
ELECTRICAL MOTORS

Single phase universal motors

They are world wide motors, dual voltages and dual frequencies, and they are in accordance with major international standards (UL, CSA, CE). On the table below are shown the technical specifications of the different motors.

 **CAUTION**

Before connecting to the mains, check the position of the voltage selector situated inside the electrical box (see next paragraph).

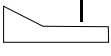
	HIGH VOLTAGE	200 to 240 V, 50/60 Hz
	LOW VOLTAGE	100 to 120 V, 50/60 Hz

Voltage selector

The motor has a main on/off bipolar switch.

The motor includes a thermal protection against overloads. If the motor is switched off by this relay, it can be started again after a few minutes.

Consult the trouble shooting section in order to understand and remove the overload cause.

NOTE

If fuses are installed on the power line, they must be in accordance with the table below.

If you start a pump at low temperature, the current absorbed by the motors will be for several seconds higher than the nominal one, for this reason the fuse on the line must be of the slow-blow type.

Motor specifications for different pumps

PUMP	NOMINAL VOLTAGE [V]	Hz	RPM	kW	START UP CURRENT [A]	FULL LOAD CURRENT [A]	MAXIMUM FUSE RATING [A]
DS 102 DS 202 DS 302	100	50	1450	0.45	44	8.8	10
	100 to 120	60	1730	0.55	42	8.8	10
	200 to 240	50	1450	0.45	27	5.4	8
	200 to 230	60	1730	0.55	24	4.4	6
DS 402 DS 602	100	50	1450	0.75	75	11.8	16
	100 to 120	60	1730	0.90	82	12.8	16
	200 to 240	50	1450	0.75	43	6.2	8
	200 to 230	60	1730	0.90	39	6.4	8

Single-Phase Universal Motors Voltage Setting

 **CAUTION**

Before connecting to the mains, check that your electrical mains voltage corresponds to the motor voltage setting.

To modify the voltage setting, change the position of the voltage selector situated inside the motor electrical box.

To confirm the change of the voltage setting from High Voltage to Low Voltage, glow the orange label above the yellow label positioned on the electrical box cover.

 **WARNING!**

Disconnect the motor from the mains before opening the electrical box.

 **WARNING!**

Close the motor electrical box cover before connecting to the main.

The motors are factory set to operate at 200-240 V (50/60 Hz) nominal voltages.

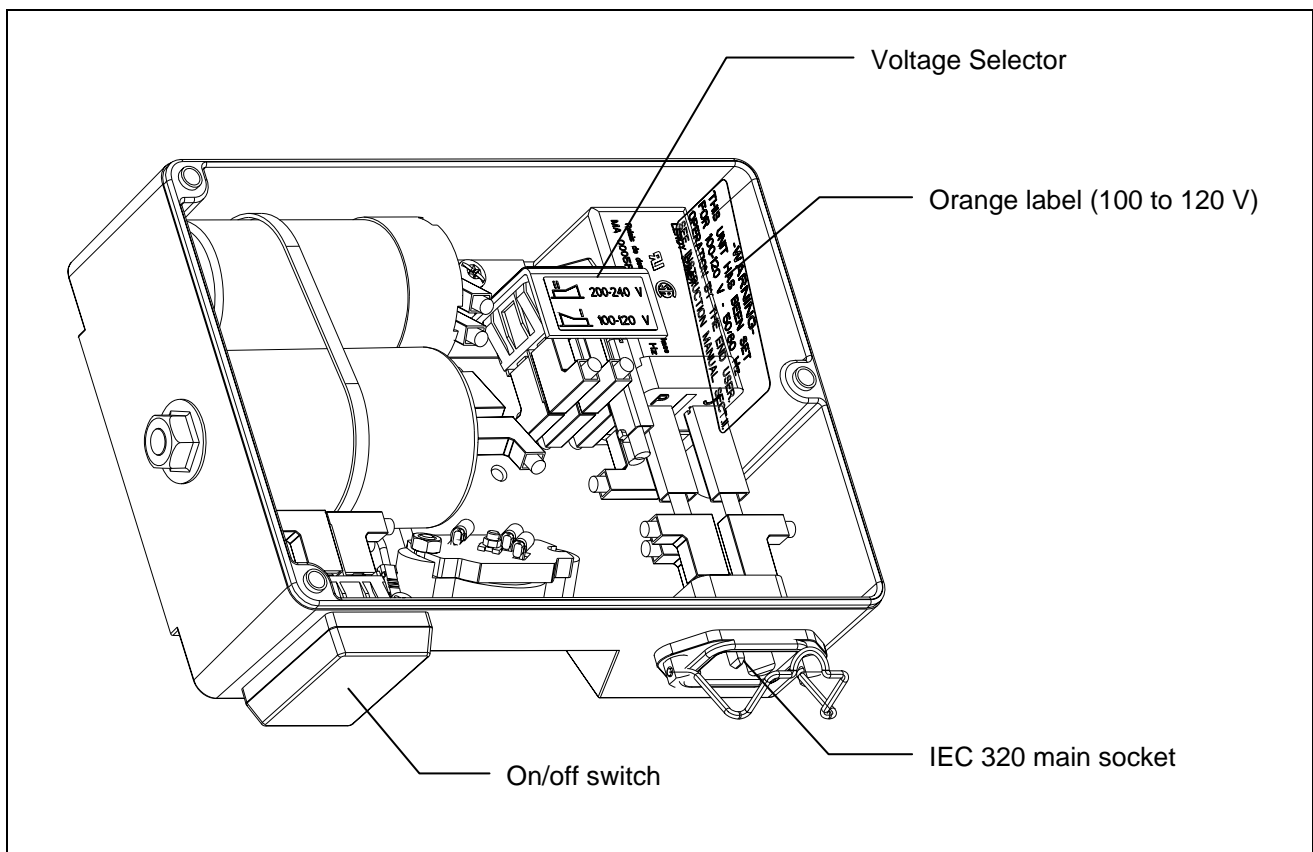

Motor Electrical box

Three phase universal motors

They are world wide motors in accordance with major international standards (UL, CSA, CE). On the table below are shown the technical specifications of the different motors.



CAUTION

Before starting the pump, give a short activation to the power switch, in order to check that the motor turns in the direction indicated by the arrow on the motor body. Should it rotate in the opposite direction, invert the connection of any two phases on the motor terminals.

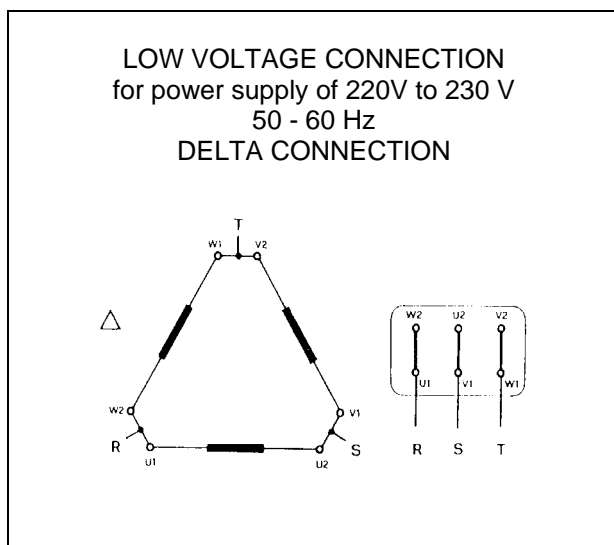
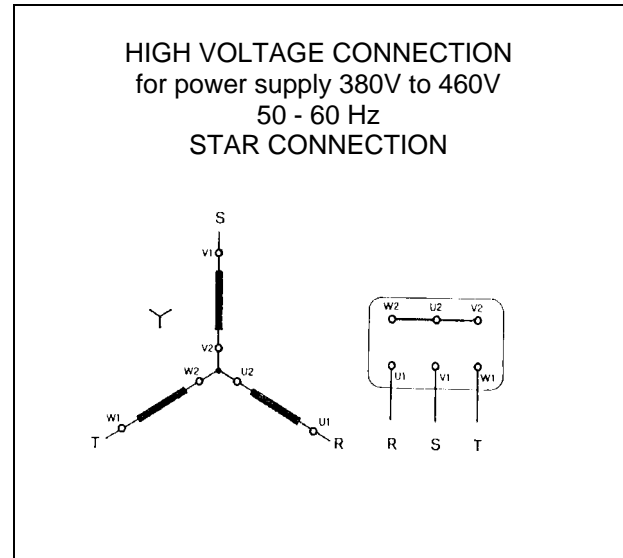

Electrical Connections of Three-Phase World Wide Motors

To connect the motor to the three-phase mains, follow the wiring diagram on the motor plate or on the inside of the terminal strip.

Install a multipolar switch on the power line, with contact spacing of at least 3 mm. A magneto-thermal switch must be installed downstream of this switch, tripping at 130-140 % of the nominal current.

CONNECTION	FREQ. [Hz]	NOMINAL VOLTAGES [V]	POWER [KW]	START UP CURRENT [A]	CURRENT [A]	MAX FUSE RATING [A]
STAR	50	380 to 415	0.75	15	2.6	4
STAR	60	460	0.90	14	2.4	4
DELTA	50	200 to 240	0.75	26	4.4	6
DELTA	60	200 to 230	0.90	21	4.8	6

 **CAUTION**

It is recommended to connect the pump to the power supply through a dedicated switch on the main electrical panel of the installation, or in proximity of the power supply connection point.

Before starting the pump, give a short activation to the power switch, in order to check that the motor turns in the direction indicated by the arrow on the motor body. Should it rotate in the opposite direction, invert the connection of any two phases on the motor terminals.

One of the most effective method to verify the rotational way of the motor, it is to start the pump with a sheet of paper on the pump inlet. If the paper is sucked by the pump then the motor runs in the right way.

CONNECTIONS TO THE INLET AND EXHAUST FLANGES

Remove the protective caps from both flanges. Connect the system to be evacuated to the inlet flange, using a centering ring with OR and a locking collar.

NOTE

For guaranteed reliable sealing, use an OR gasket in Perbunan or Viton.

The inlet duct is equipped with a sieve filter preventing solid particles from entering and damaging the pump.

NOTE

When the gases to be pumped out contain dust, it is advisable to insert a dust filter before the inlet flange.

NOTE

When the gases to be pumped out contain large quantities of vapor, it is advisable to include a condense separator before the inlet flange.

To make best use of the pump's capacity, use only short, straight piping, with a diameter not smaller than that of the inlet flange.

NOTE

If rigid piping is used, it is good practice to use a flexible joint in order to avoid undue forcing of the connection on the pump.

The exhaust duct must be connected to a pipe that will take away the pumped out gases.

NOTE

Application of an oil trap filter is necessary to avoid pollution of the surrounding atmosphere by the oil present in the exhaust duct during pump operation.

 **CAUTION**

Never block the pump exhaust line. This would cause overpressure in the casing with the risk of breaking the glass window of the level indicator and/or expelling the oil seal gasket.

STARTING AND RUNNING THE PUMP

Before being put into service, in order to reach maximum vacuum, the pump must be left running for about an hour with the gas ballast valve open. This will eliminate any humidity from the oil.

 **WARNING!**

The pump is designed for operation with neutral or non-corrosive fluids. It is absolutely forbidden to use potentially explosive or flammable substances.

NOTE

If the pump is started with cold oil, initially more than normal noise will be heard; this will last for a few minutes only until the oil reaches its working temperature.

There are no special instructions for normal operation of the pump, which is delivered to you after completion of a running-in cycle in the factory. The maintenance operations for a pump in working condition may be found on the Scheduled Maintenance Cards.

If the pump is sucking in environments with liquids or vapors, it is important to leave it to run with the gas ballast open so as to avoid condensation of the vapors and contamination of the lubricating oil as a result. When there is no danger of the oil being contaminated, the gas ballast valve should be closed to reduce the pump's power absorption.

The gas ballast valve will prove useful in the cold season when, due to the lower room temperatures, it takes longer for the pump to reach rated temperature when switched on. Compression of the air forced in by the gas ballast valve develops heat, which in turn increases temperature of the oil faster.

NOTE

If gases without vapors are sucked in, you are advised to open the gas ballast device from time to time in order to eliminate the traces of humidity they contain.

NOTE

For repetitive work cycles, with brief time intervals in between, it is better not to stop the pump.

STOPPING THE PUMP

There are no special procedures for switching the pump off; it needs only to be disconnected from the electric power by means of the bipolar switch (version with single-phase motor - see section *MODELS WITH SINGLE-PHASE UNIVERSAL MOTORS*) or of the multipolar switch (version with three-phase motor - see section *MODELS WITH THREE-PHASE UNIVERSAL MOTORS*).

When the pump is stopped, the anti-suckback device makes it possible to maintain vacuum in the vessel connected on the inlet flange of the pump.

If the pump is expected to be stopped for a lengthy period, or in any case if it has pumped in large amounts of vapors, it is good practice to run it with the gas ballast open and the inlet line closed for a few minutes before switching off in order to limit the risk of corrosion or scaling due to pollution of the oil by condensed vapors.

SAFETY RULES

Personnel responsible for pump operation and maintenance must be well-trained and must be aware of the accident prevention rules.

The accident prevention precautions contained in this section must be respected at all times during operation and maintenance of the pump to avoid damage to operators and to the pump.

These precautions are provided in the form of WARNING and CAUTION notes.



WARNING!

Operating procedures, technical information and precautions which, if not respected and/or implemented correctly may cause body harm to operators.



CAUTION

Operating procedures, technical information and precautions which, if not respected and/or implemented correctly may cause damage to the pump.

WARNING NOTES

- a. Death may result from contact with high voltages. Always take extreme care and observe the accident prevention regulations in force.
- b. Always disconnect the power supply to the pump before maintenance work. Place a special warning signs over the power supply breaker switch: MACHINE UNDERGOING MAINTENANCE - DO NOT POWER ON.
- c. If you are performing maintenance after the pump has been operating for a considerable time, allow sufficient time for it to cool as the external surface temperature may be in excess of 60 °C.
- d. Failure to provide the pump with an earth connection may cause serious damage to operators. Always ensure that there is an earth connection and that it complies with the standards.
- e. When cleaning the pump and its component parts, avoid the use of flammable or toxic solvents, such as benzine, benzol, ether or alcohol. The recommendation is to use a soap and water solution, preferably in ultrasound washing machines, taking care to dry all the cleaned parts at temperatures under 100 °C in order to eliminate residual moisture.
- f. Prolonged overloads or breakdowns may cause the electric motor to overheat, and to release noxious smoke; remove the power immediately as a precaution and do not approach the pump at least until you have provided ventilation to drive out the smoke. Take care not to breathe in the fumes remaining inside the pump in the course of repair work.
- g. In case of fire, do not throw water on the pump. Switch the power off and use CO₂ extinguishers.
- h. Carefully inspect the flanges to ensure that there are no dust, oil, dirt or defects of the mating surfaces, before making the required connections.
- i. Ensure that all joints and couplings are locked correctly before starting the pump again after repair work.
- j. Do not wear any objects that may become entangled in the mechanisms and/or act as conductors (chains, bracelets, etc.).
- k. Ensure that the tools to be used are in perfect working condition and have insulating grips, where necessary. Check that the insulating material of the cables and that the conductors of the test equipment do not show any signs of damage.

- l. Do not replace the oil immediately after stopping the machine as the oil may still be at high temperature.
- m. Perform repairs in clean and, where possible, dust-free areas. Protect all the clearances of connection points with suitable plastic caps and cover the machined surface areas of all parts stripped down until they are put back on the pump again.
- n. Do not start the pump if the protective side-plates (refs. 11 and 81 of fig. *View of the pump*) are not properly in place.

CAUTION NOTES 

- a. Before putting the pump back into operation after a breakdown, inspect it and check carefully for any other signs of damage.
- b. Use only tools that are in perfect working order and specially designed for the job; use of inappropriate or ineffective tools may cause serious damage.
- c. Perform repairs in clean and, where possible, dust-free areas. Protect all the clearances of connection points with suitable plastic caps and cover the machined surface areas of all parts stripped down until they are put back on the pump again.
- d. Always check the lubricant and that it is properly distributed through the pump; inadequate lubrication may damage the pump seriously.
- e. Give the parts some form of marking as you strip them down to ensure that you reassemble them again in the proper order.
- f. Check that there are no scratches or grooves on the machined shafts, in their seats inside the pump or on machine-ground surfaces. Slight scratches and abrasions may be eliminated with very fine emery paper or by a little light grinding.
- g. Before putting a group together, always spread a little oil over inner parts and mating surfaces. Replace all seals with original spare parts before reassembling components.

MAINTENANCE ACTIONS

Maintenance may be seen as the totality of all scheduled and unscheduled maintenance work.

Maintenance includes:

- 1. **SCHEDULED MAINTENANCE:** Maintaining the nominal state of operation.
- 2. **UNSCHEDULED MAINTENANCE:** Restoring the nominal state of operation

NOTE

The frequency with which repairs are performed depends on the process and presence of substances that shorten pump life (dust, abrasives, solvents, water, chemically aggressive substances).

The pump must be cleaned at regular intervals of time.

 **CAUTION**

Do not clean with Alcohol the plastic or rubber components of the pump.

Use only the strictly necessary amount of lubricant; an excess of lubricating oil, like when there is none, may sometimes compromise proper operation of the pump.

Only the recommended lubricants, or lubricating oils with similar characteristics and known and experimented quality, should be used.

Oil changes must be made with the oil at a sufficiently high temperature, after leaving the pump to cool for a few minutes following operation.

The drain and filler plugs must not be left open any longer than is strictly necessary.

When performing maintenance, look out for all signals that may precede a breakdown, in particular:

- traces of corrosion;
- oil leaks;
- slack joints or couplings.

Maintenance technicians must:

- be aware of all applicable national directives concerning accident prevention during work on motor-driven pumps and should know how to apply them;
- have read and understood all the sections on "Safety Rules";
- be familiar with the essential design features and operation of the pump;
- know how to use and consult the pump documentation;
- be concerned about proper operation of the pump;
- make a note of any irregularities in operation of the pump and take the necessary action, where appropriate.

Use original spare parts wherever possible and repair a broken part as best as possible on site or send it back to the manufacturer for repairs.

For all problems arising, or to order spare parts, refer to our service department.

Varian S.p.A. - Vacuum Technologies
Via Varian 54
10040 Leini (Torino) - Italy
Telephone: (39) 011.9979111
Fax: (39) 011.9979344

LUBRICANTS

It will be readily understood how important adequate lubrication is to high technology pumps like the Varian vacuum pumps. Correct use of appropriate lubricants makes a significant contribution to achieving best performance and warding off defects.

When handling lubricants, the following sanitary protection measures should be observed at all times:

- Avoid prolonged, excessive or repeated contact of the skin with products for lubrication, and also avoid directly inhaling the fumes or vapors of such products.
- Protect the skin by wearing appropriate clothes and equipment (e.g. special suits, glasses or, where permitted by the safety regulations, gloves) or by applying a special protective product.
- Clean the skin carefully after contact with the lubricants by washing freely with water and soap.
- Apply a skin cream after washing.
- Take off and change clothes or shoes on which oil has been spilled.
- Never put rags dripping with oil into the pockets of your clothes.

When disposing of waste lubricants, observe the following environment protection regulations:

- The lubricants risk contaminating the water and the ground! Therefore never pour lubricating products on to the ground, into water or in the sewage system. All violations of these rules are liable to persecution as provided for by law. When using lubricants always keep an oil can nearby.
- Take care in draining off waste oils. In disposal of these products respect all regulations in force concerning waste oil disposal.

The recommended lubricating oil is the Varian Rotary Vane Fluid DS19 Type. The Rotary Vane Fluid DS19 Type is a general purpose mechanical pump fluid specifically engineered to provide superior performance in high speed direct drive mechanical pumps.

These precisely distilled fluids (100% solvent refined neutral paraffinic oil) deliver lower base pressure capability, faster pump-down cycles, and reduced maintenance requirements on both the pump and the fluid.

It is absolutely necessary to continue using the lubricants initially used to fill the tank. If this is not possible for organizational or business reasons, use only products with the same characteristics as the previous oils.

Only use of lubricants of suitable quality will guarantee safe operation of the pumps.

 **CAUTION**

Mineral oils and the PFPE oil are incompatible. To change from one type to another, the pump must be stripped down completely and all parts washed carefully to eliminate all oil residues.

If you expect to have to use other lubricants, first find out if the two products are compatible. In cases of doubt, the lubricant used up to that time must be flushed out by way of a pump flushing procedure.

 **CAUTION**

To avoid the risk of contaminating the oil, absolute cleanliness of the pump and surrounding area must be ensured during the lubrication procedures.

Varian Rotary Vane Fluid DS19 Type characteristics

PROPERTY	UNIT OF MEASURE	ROTARY VANE FLUID DS19 Type
Vapor pressure @ 25 °C	Torr	1·10 ⁻⁵
Boiling point @ 0,01 torr	°C (°F)	112 (233)
Viscosity @ 40 °C	cSt (SUS)	55 (258)
Viscosity @ 100 °C	cSt (SUS)	8,1 (52,7)
Pour point	°C (°F)	-15 (5)
Flash point	°C (°F)	213 (415)
Fire point	°C (°F)	244 (472)
Density @ 25 °C	g/ml	0,87

Varian Rotary Vane Fluid DS19 Type vapor pressure curve

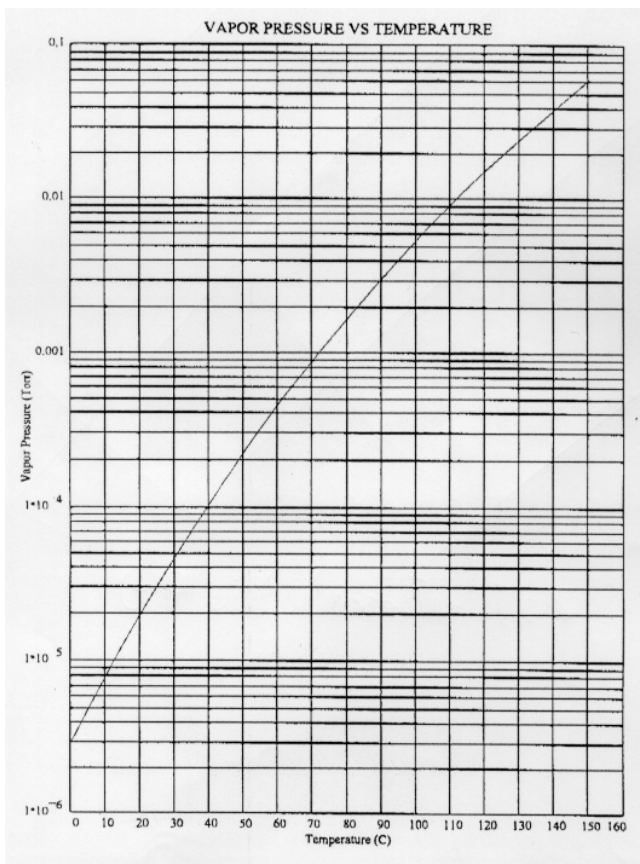

Varian Rotary Vane Fluid DS19 Type viscosity curve

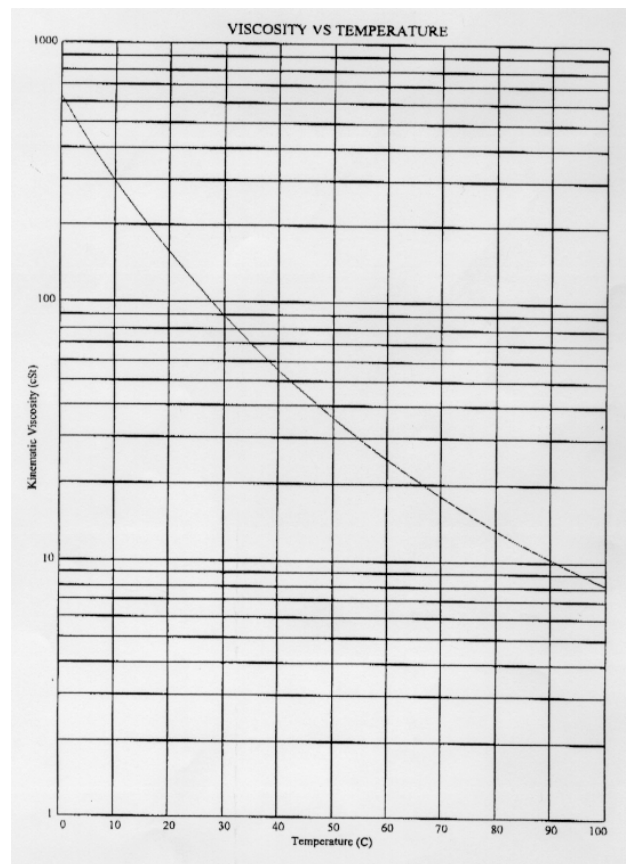

SCHEDULED MAINTENANCE CARDS

No.	FREQUENCY	PUMP STATUS (*)	OPERATION
01	MONTHLY	R	OIL LEVEL CHECKING
02	TWICE YEARLY	S	CLEANING THE INLET FILTER

(*) R=RUNNING S=STOPPED

NOTE

When the pump is equipped with:

- *a filter for dust on the inlet side*
 - *a condensation separator on the inlet side*
- these items must also be maintained, by following the Manufacturer's instructions.*
-

NOTE

The numbers used in the drawings on the Scheduled Maintenance Cards are those used in Figure View of the pump.

	Scheduled Maintenance	Card No. <div style="border: 1px solid black; width: 60px; margin: 5px auto; text-align: center;">01</div>
---	------------------------------	--

Pump type:	DS102 1Ph, DS202 1Ph, DS302 1Ph, DS402 1Ph, DS402 3Ph, DS602 1Ph, DS602 3Ph
-------------------	---

Frequency:	<div style="border: 1px solid black; padding: 2px;">MONTHLY</div>	Time:	<div style="border: 1px solid black; padding: 2px;">5 min.</div>	Machine status:	<div style="border: 1px solid black; padding: 2px; display: inline-block;">S</div> <div style="border: 1px solid black; padding: 2px; display: inline-block; margin-left: 5px;">R</div>
-------------------	---	--------------	--	------------------------	---

Type of action:	<div style="border: 1px solid black; padding: 2px;">LUBRICATION</div>
Item:	<div style="border: 1px solid black; padding: 2px;">LUBRICATING OIL 949-9390</div>

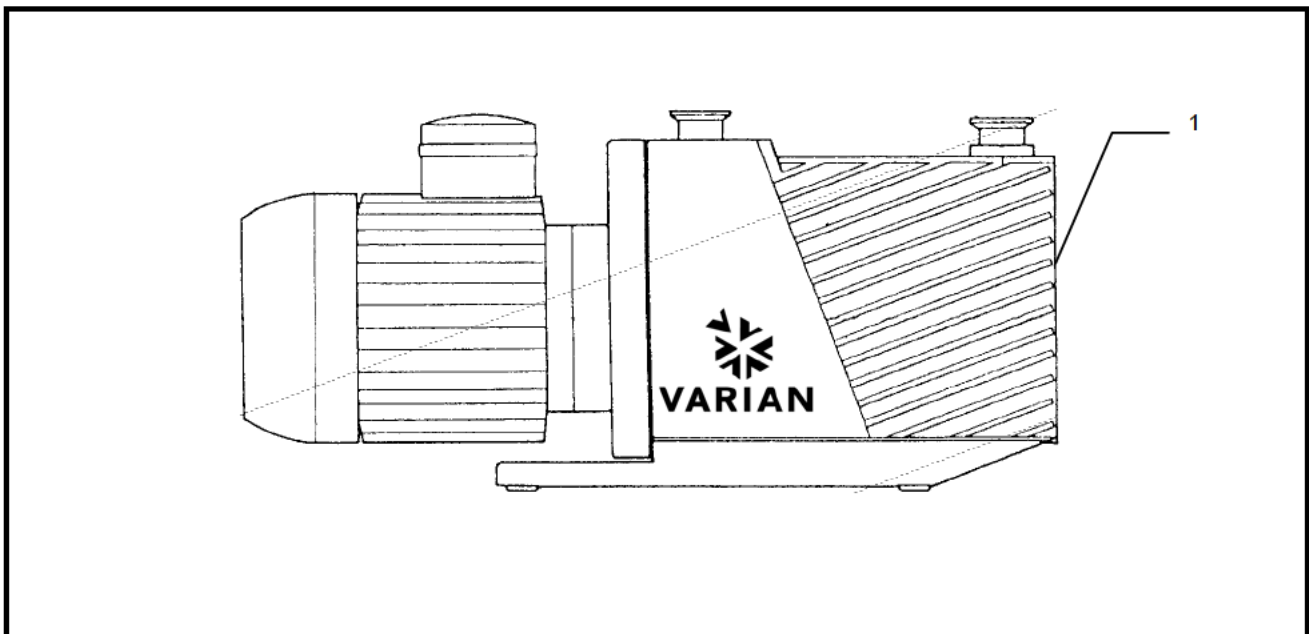

No.	Description	Time	Equipment	Materials
1	Check the oil level and top up if necessary.	5 min	<ul style="list-style-type: none"> • Cleaning rags • Liquid detergent 	Oil P/N 949-9390

 **WARNING!**

Machine powered: take care on account of moving parts and high voltages.

 **WARNING!**

If you have to perform maintenance on the pump after a considerable time in operation, leave it to cool as temperature of the outer surface may be in excess of 60°C.

1. Check the oil level through the sight glass: there are two clearly visible arrows indicating maximum and minimum levels for proper pump operation.

NOTE

The amount of oil consumed depends on the type of work, particularly on the volume being evacuated and on the frequency of the vacuum cycles.

2. If necessary, open the pump filling plug on the top plane of the pump and add oil.

NOTE

Before starting the procedure, check that the quality and type of oil used corresponds to the indications of Table Varian Rotary Vane Fluid DS19 Type characteristics of this manual.

 **CAUTION**

Take great care to avoid oily residues or dust from entering the pump and jeopardizing proper operation.

3. Close the fill plug and, using cotton or other suitable material rags, clean thoroughly the outer surface of the top plane of the pump.

 **CAUTION**

Never mix lubricants of different brands or quality. To change from one oil to another, the pump must be stripped down and all parts washed carefully, taking care to eliminate oil residues.

4. Open the gas ballast valve to purify the oil.

	Scheduled Maintenance	Card No. <div style="border: 1px solid black; width: 40px; margin: 0 auto; text-align: center; padding: 2px;">02</div>
---	------------------------------	--

Pump type:	DS102 1Ph, DS202 1Ph, DS302 1Ph, DS402 1Ph, DS402 3Ph, DS602 1Ph, DS602 3Ph
-------------------	---

Frequency:	<div style="border: 1px solid black; padding: 2px;">TWICE YEARLY</div>	Time:	<div style="border: 1px solid black; padding: 2px;">10 min.</div>	Machine status:	<div style="display: inline-block; border: 1px solid black; padding: 2px; margin-right: 5px;">S</div> <div style="display: inline-block; border: 1px solid black; padding: 2px;">R</div>
-------------------	--	--------------	---	------------------------	--

Type of action:	<div style="border: 1px solid black; padding: 2px;">CLEANING</div>
Item:	<div style="border: 1px solid black; padding: 2px;">INLET FILTER</div>

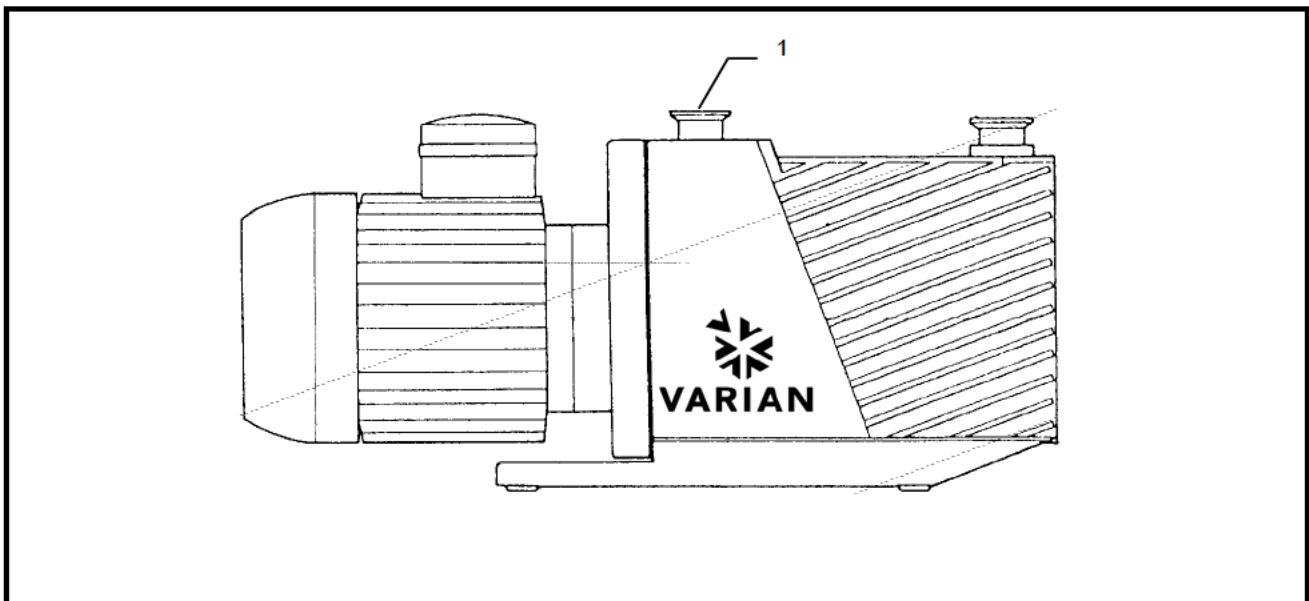

No.	Description	Time	Equipment	Materials
1	Clean the suction filter.	10 min.	<ul style="list-style-type: none"> • Compressed air gun 	

 **WARNING!**

Machine safety: disconnect all power lines. Hang the card "MACHINE UNDERGOING MAINTENANCE - DO NOT POWER ON" from the main breaker switch. When finished, remove the safety warning.

 **WARNING!**

If you have to perform maintenance on the pump after a considerable time in operation, leave it to cool as temperature of the outer surface may be in excess of 60 °C.

1. Remove the filter (26) from the inlet flange (28).
2. Clean the filter using an aqueous solution and dry with hot air.
3. Put the filter back in place.

 **CAUTION**

The filter element is designed to prevent solid particles in the air from entering the inside of the pump and if it is not working properly, serious damage could be caused the pump's inner parts. In such cases, it may be worthwhile installing a large surface area filter in the pump's suction line to improve effectiveness and reduce maintenance frequency.

If the pump sucks in gases and vapors that contain large quantities of solid particles, the filter must be checked and cleaned more often than indicated here.

UNSCHEDULED MAINTENANCE CARDS

No.	SUBJECT	FREQUENCY
101	General Warnings	
102	Changing the oil	Whenever necessary
103	Disassembly of oil level indicator	When damaged
104	Disassembly of anti-suckback device shutter	When damaged
105	Disassembly of electric motor and joint	When damaged
106	Disassembly of discharge valve	When damaged
107	Disassembly of oil circulating pump	When damaged
108	Disassembly of anti-suckback valve	When damaged
109	Disassembly of pump body	When damaged
110	Replacement of oil seal ring/wear bushing	When damaged
111	Disassembly of functional block rotors	When damaged

NOTE

The numbers used in the drawings on the Unscheduled Maintenance Cards are those used in Figure View of the pump.

	<p>Unscheduled Maintenance</p>	<p>Card No.</p> <div style="border: 1px solid black; padding: 2px; width: fit-content; margin: 0 auto;">101</div>
---	--------------------------------	---

Pump type: DS102 1Ph, DS202 1Ph, DS302 1Ph, DS402 1Ph, DS402 3Ph, DS602 1Ph, DS602 3Ph

Frequency: Time: Machine status:

Type of action: GENERAL WARNINGS

Item:

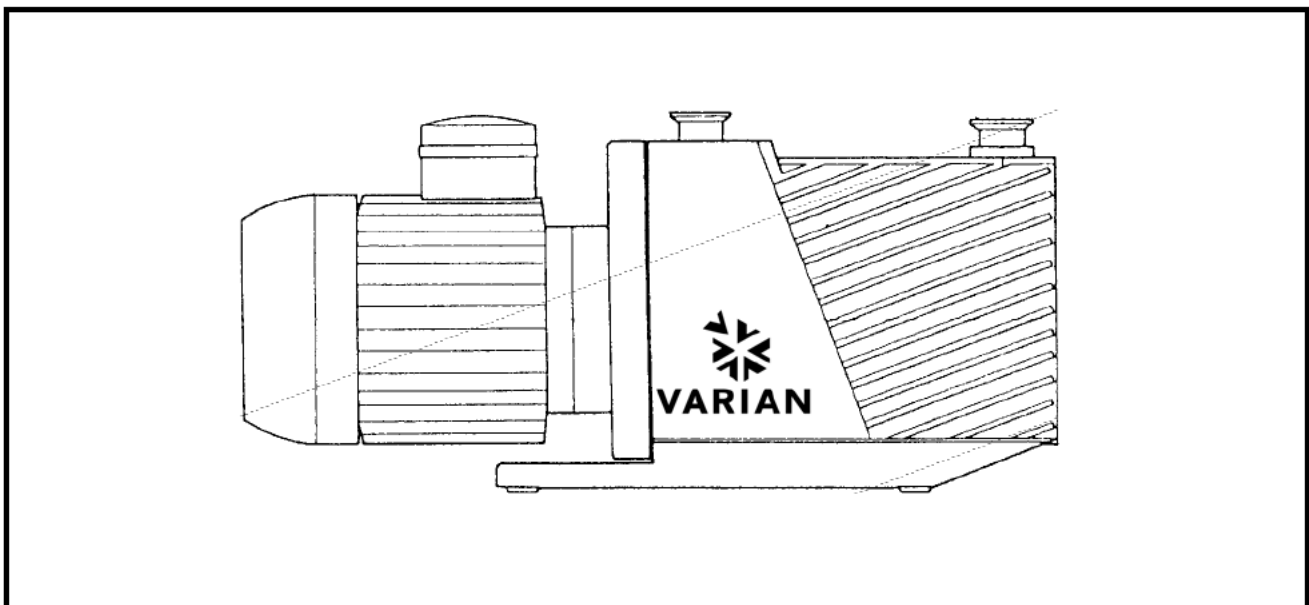

1. Pump disassembly and reassembly require some basic operations and use of tools found in most work-shops.

NOTE

The pump's component parts are modular and therefore fully interchangeable. Whenever parts have to be replaced, please specify in the order:

- Pump type
- Serial number (marked on pump identification plate).
- Reference number on the detailed diagram, name and part number as indicated on the spare parts and accessories list (section SPARE PARTS LIST of this manual).

To simplify maintenance work, two kits have been devised.

The Gaskets Kit, containing all the gaskets recommended for substitution after disassembly of the pump and the most commonly used removable parts.

You are advised to keep this kit in a dry room, away from heat and light (sun and UV rays) in order to prevent hardening of the elastomer parts.

The Maintenance Kit, including, as well as the Gaskets Kit, the 1st and 2nd stage vanes and other parts that it may be necessary to replace when overhauling the pump completely. These parts have a life of approx. two years under conditions of normal operation.

KIT	PUMP TYPE					ORDER CODE
	DS102 1Ph	DS202 1Ph	DS302 1Ph	DS402 1Ph DS402 3Ph	DS602 1Ph DS602 3Ph	
GASKETS KIT	X	X	X			949-9370
GASKETS KIT				X	X	949-9371
MAINTENANCE KIT	X					949-9380
MAINTENANCE KIT		X	X			949-9381
MAINTENANCE KIT				X	X	949-9382

2. Before reassembling the pump, all parts must be cleaned thoroughly with a soap and water solution and rinsed with demineralized water.

 **CAUTION**

Particular care must be taken in cleaning the lubrication ducts and oil passage nozzles, which must always be kept free of impurities.

 **CAUTION**

Take care that the soap and water solution does not remain in the various cavities and recesses of the pump, in the blind holes in particular.

3. Then dry the parts, by heating where possible but without using compressed air (it generally contains polluting substances), taking care not to exceed a temperature of 80 °C.
4. The sequence of reassembly is the inverse of the disassembly operation. Take the same precautions:
 - Spread some clean oil of the same type as used to lubricate the pump over the different parts, in particular the inner lip of the oil seal, the bushings and vanes.
 - If the oil seal has the dust-block lip, 2/3 fill the area between the two lips with ISOFLEX TOPAS NB5051 grease.

 **CAUTION**

Do not allow the grease into the area of the circumferential spring.

- Lock without forcing the nuts on the four tie-rods (44) connecting the parts of the pump block. Before locking, check that all parts are touching as required.
- Before putting the springs and shutters of the discharge valves back in, pour a little oil into the stators through the holes in the valves.

 **CAUTION**

Before hooking the recall spring to the anti-suckback command bar, make sure you have put the bar all the way into the sleeve of the rotary feedthrough to avoid bending the tapered part of the bar.

NOTE

On DS102 1Ph, DS202 1Ph and DS302 1Ph pumps, fit the joint on the motor shaft after careful removal of grease from the surfaces and application of LOCTITE 242.

VARIAN <i>vacuum technologies</i>	Unscheduled Maintenance	Card No.
		<div style="border: 1px solid black; padding: 2px; display: inline-block;">102</div>

Pump type:	<div style="border: 1px solid black; padding: 2px;">DS102 1Ph, DS202 1Ph, DS302 1Ph, DS402 1Ph, DS402 3Ph, DS602 1Ph, DS602 3Ph</div>
-------------------	---

Frequency:	<div style="border: 1px solid black; padding: 2px;">AS REQUIRED</div>	Time:	<div style="border: 1px solid black; padding: 2px;">30 min.</div>	Machine status:	S	R
-------------------	---	--------------	---	------------------------	----------	----------

Type of action:	<div style="border: 1px solid black; padding: 2px;">CHANGING OIL</div>
Item:	<div style="border: 1px solid black; padding: 2px;">LUBRICANT 949-9390</div>

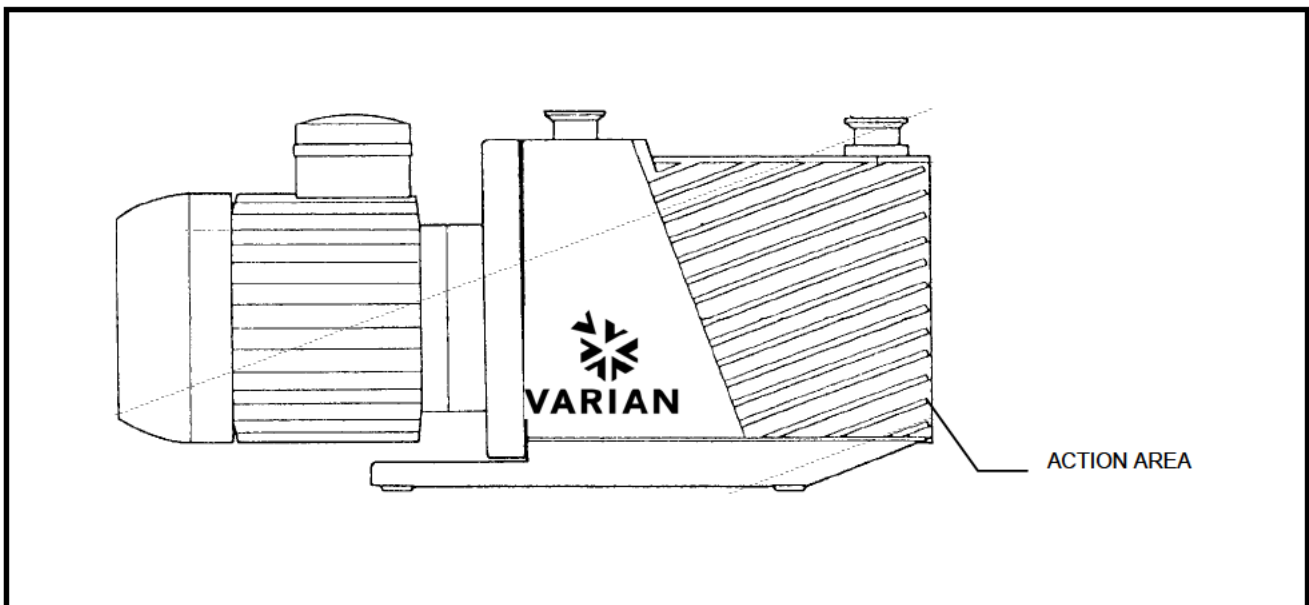

Materials required:	Equipment required:
<ul style="list-style-type: none"> • Varian Rotary Vane Fluid DS19 Type (1 liter) P/N 949-9390 	<ul style="list-style-type: none"> • Fixed wrench for oil exhaust. • Tank to collect oil. • Cotton (or other suitable material) rags for cleaning. • Soap and water solution for cleaning.

WARNING!

Do not change the oil immediately after stopping the machine as the oil temperature may still be high.

WARNING!

Machine safety: disconnect all power lines. Hang the card "MACHINE UNDERGOING MAINTENANCE - DO NOT POWER ON" from the main breaker switch. When finished, remove the safety warning.

! WARNING!

If you have to perform maintenance on the pump after a considerable time in operation, leave it to cool as temperature of the outer surface may be in excess of 60 °C.

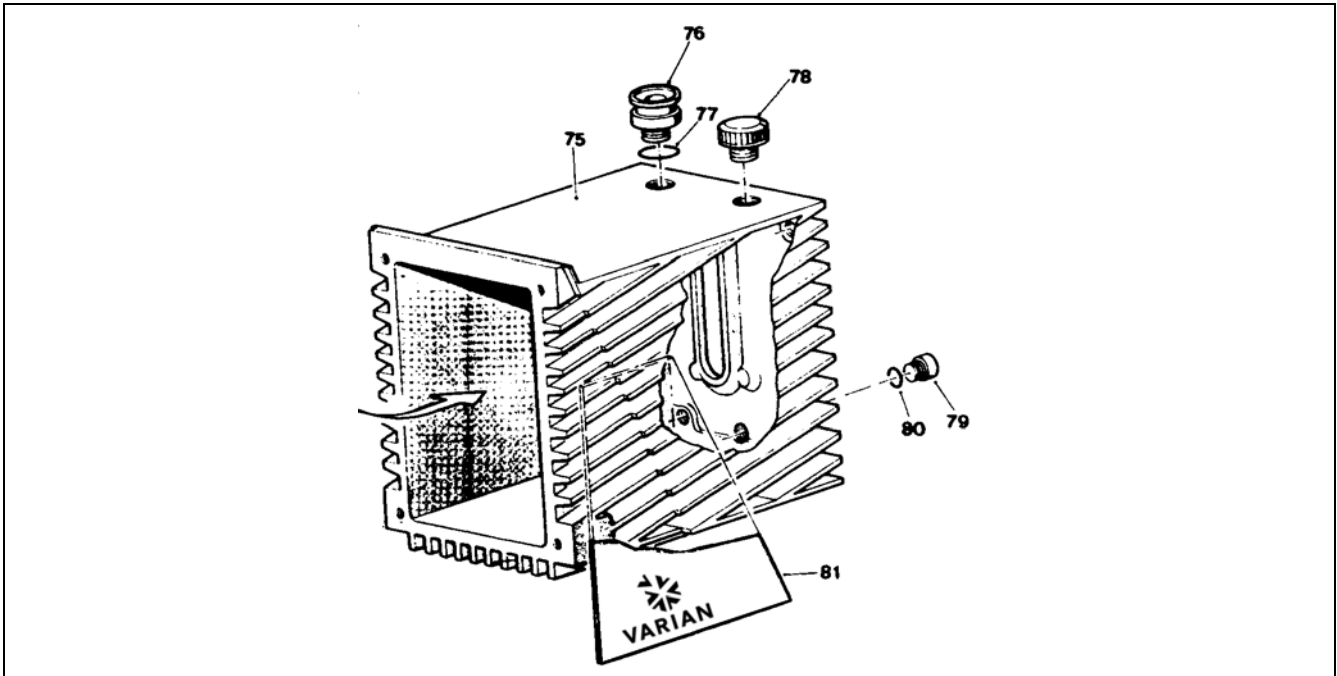

NOTE

The oil has to be replaced:

- 1) when it has become particularly dirty due to the presence of contaminants in the environments being evacuated;
- 2) when the degree of vacuum achieved by the pump is no longer satisfactory, even after running for one hour with the gas ballast device open.

1. Place a tank for the waste oil under the oil drain plug (79).

NOTE

You are advised to empty the pump before it cools down completely so that the oil flows out more easily.

NOTE

The pump contains up to 1 liter of oil - make sure the tank you use for the waste oil can hold this amount.

2. Open the oil drain plug (79) slowly; let the oil flow out by opening the fill plug (78) located at the top of the pump. In the meantime, clean the inside of the drain plug (magnetic plug).
3. After closing the drainage hole with its plug, make the pump perform a number of turns, giving it a brief current pulse, so as to let residual oil in the pump chambers flow out. Then drain off the residual oil again.
4. After all the oil has been drained, close the drain plug tight; take the tank of waste oil away and clean thoroughly, using rags of cotton or other suitable material to dry.
5. Clean thoroughly the pourer lip of the new oil tin; pour the oil slowly into the pump through the filler plug (78).

NOTE

Monitor through the sight glass at the front of the pump that you are not exceeding the maximum oil level permitted.

 **CAUTION**

For disposal of waste oil, it is strictly necessary to respect the currently applicable legislation on this matter.

6. To achieve a good vacuum level again, run the pump for one hour with the gas ballast open.

VARIAN <i>vacuum technologies</i>	Unscheduled Maintenance	Card No.
		<div style="border: 1px solid black; padding: 2px; display: inline-block;">103</div>

Pump type:	<div style="border: 1px solid black; padding: 2px;">DS102 1Ph, DS202 1Ph, DS302 1Ph, DS402 1Ph, DS402 3Ph, DS602 1Ph, DS602 3Ph</div>
-------------------	---

Frequency:	<div style="border: 1px solid black; padding: 2px;">WHEN DAMAGED</div>	Time:	<div style="border: 1px solid black; padding: 2px;">30 min.</div>	Machine status:	<div style="border: 1px solid black; padding: 2px; display: inline-block;"> S R </div>
-------------------	--	--------------	---	------------------------	---

Type of action:	<div style="border: 1px solid black; padding: 2px;">DISASSEMBLY</div>
Item:	<div style="border: 1px solid black; padding: 2px;">SIGHT GLASS</div>

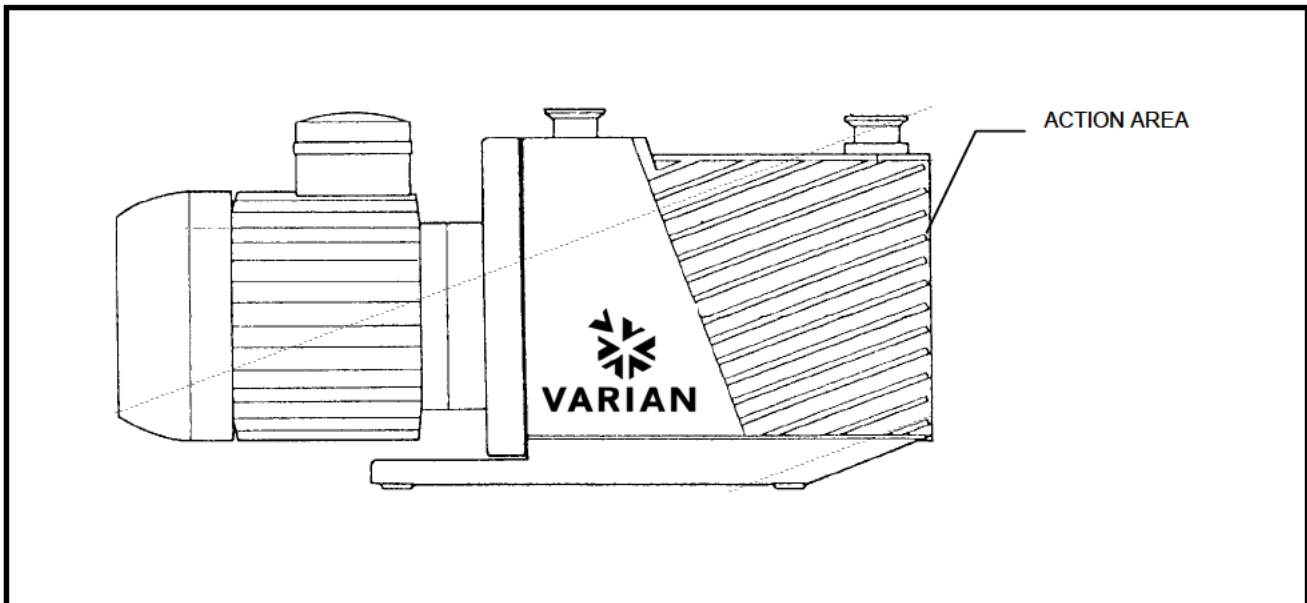

Materials required:	Equipment required:
<ul style="list-style-type: none"> • OR gaskets (for pumps DS102 1Ph, DS202 1Ph and DS302 1Ph Gaskets kit p/n 949-9370) (for pumps DS402 1Ph, DS402 3Ph, DS602 1Ph and DS602 3Ph Gaskets kit p/n 949-9371) • Sight glass 	<ul style="list-style-type: none"> • Mechanical tools

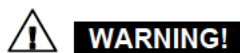

Machine safety: disconnect all power lines. Hang the card "MACHINE UNDERGOING MAINTENANCE - DO NOT POWER ON" from the main breaker switch. When finished, remove the safety warning.

! WARNING!

If you have to perform maintenance on the pump after a considerable time in operation, leave it to cool as temperature of the outer surface may be in excess of 60 °C.

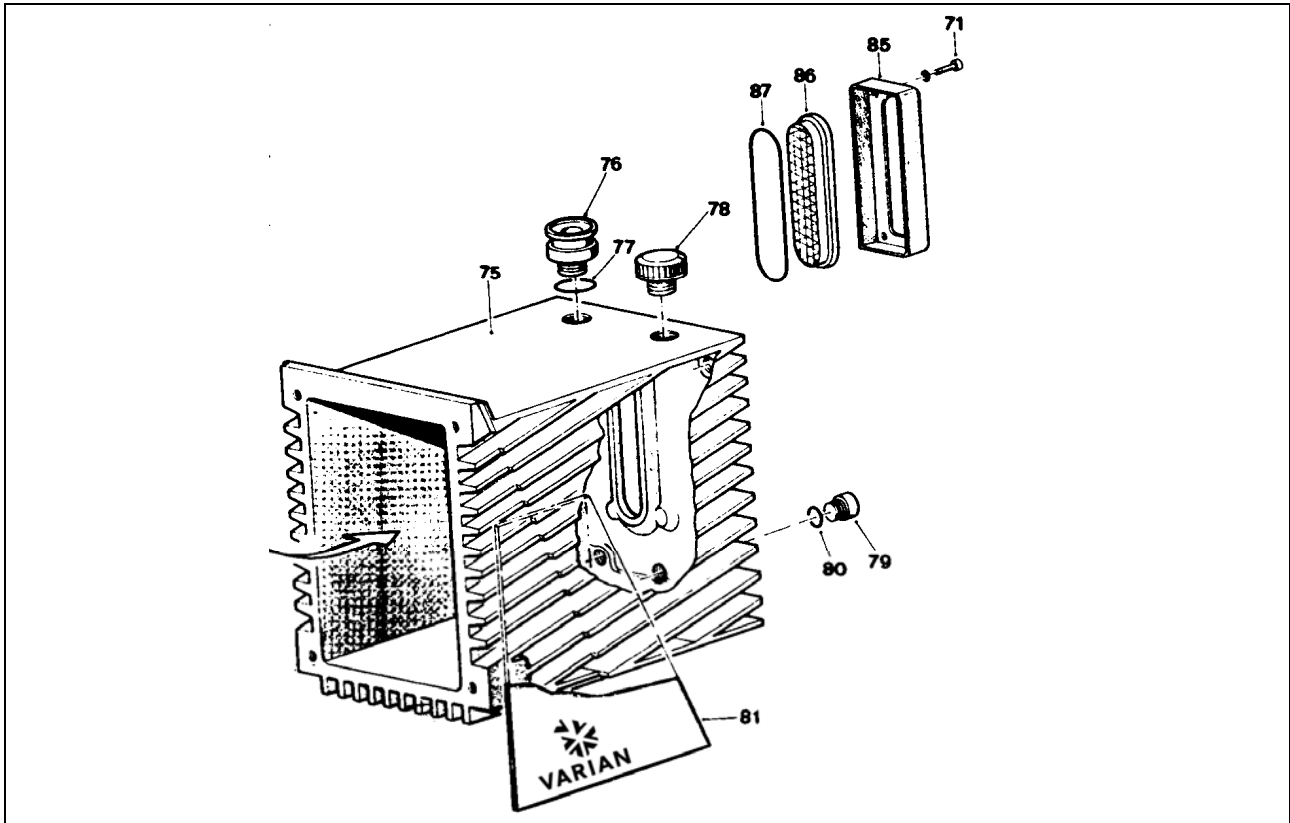

1. Drain off the oil from the pump.

NOTE

For a description of how to drain off the oil, see the Unscheduled Maintenance Card No. 102.

2. Unscrew the securing screws (71) and disconnect the flange (85) from the casing.
3. Take out the OR gasket (87) and the sight glass (86).

NOTE

When reassembling, replace the gaskets that you have stripped down.

☞ CAUTION

When reassembly is complete, proceed to fill the pump with oil again following the instructions of Unscheduled Maintenance Card No. 102.

VARIAN <i>vacuum technologies</i>	Unscheduled Maintenance	Card No. <div style="border: 1px solid black; padding: 2px; width: fit-content; margin: 0 auto;">104</div>
---	--------------------------------	--

Pump type:	DS102 1Ph, DS202 1Ph, DS302 1Ph, DS402 1Ph, DS402 3Ph, DS602 1Ph, DS602 3Ph
-------------------	---

Frequency:	WHEN DAMAGED	Time:	30 min.	Machine status:	<div style="border: 1px solid black; padding: 2px; display: inline-block;">S</div> <div style="border: 1px solid black; padding: 2px; display: inline-block; margin-left: 5px;">R</div>
-------------------	--------------	--------------	---------	------------------------	---

Type of action:	REPLACEMENT
Item:	ANTI-SUCKBACK DEVICE SHUTTER

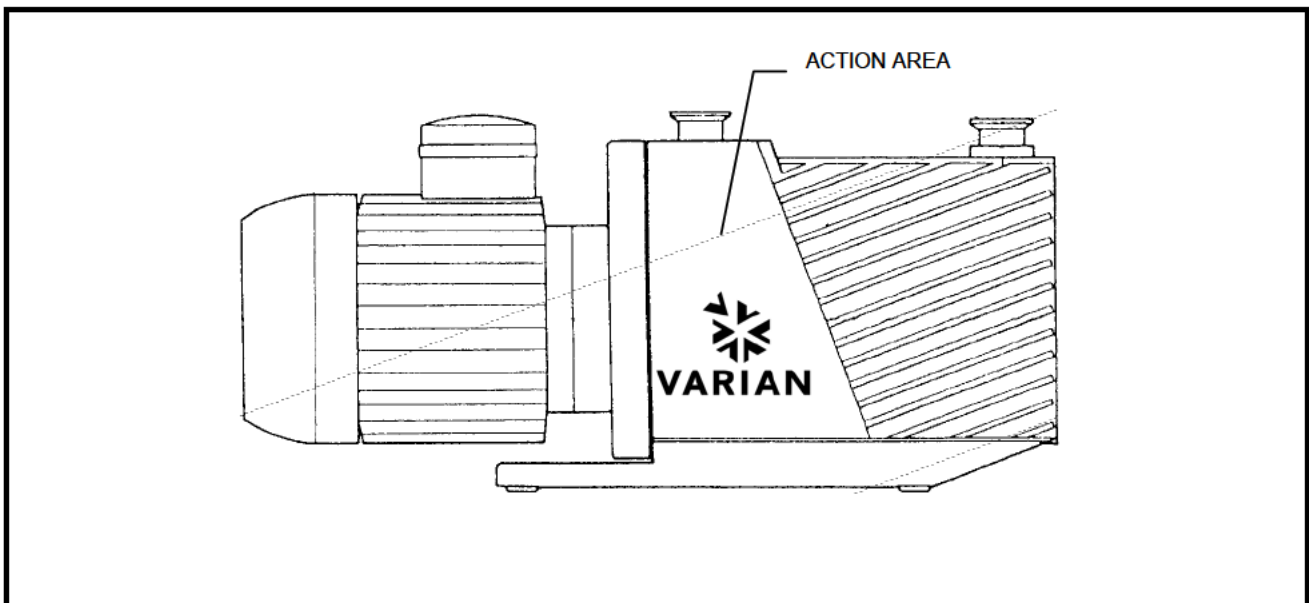

Materials required:	Equipment required:
<ul style="list-style-type: none"> • Shutter 	<ul style="list-style-type: none"> • Mechanical tools

WARNING!

Machine safety: disconnect all power lines. Hang the card "MACHINE UNDERGOING MAINTENANCE - DO NOT POWER ON" from the main breaker switch. When finished, remove the safety warning.

WARNING!

If you have to perform maintenance on the pump after a considerable time in operation, leave it to cool as temperature of the outer surface may be in excess of 60 °C.

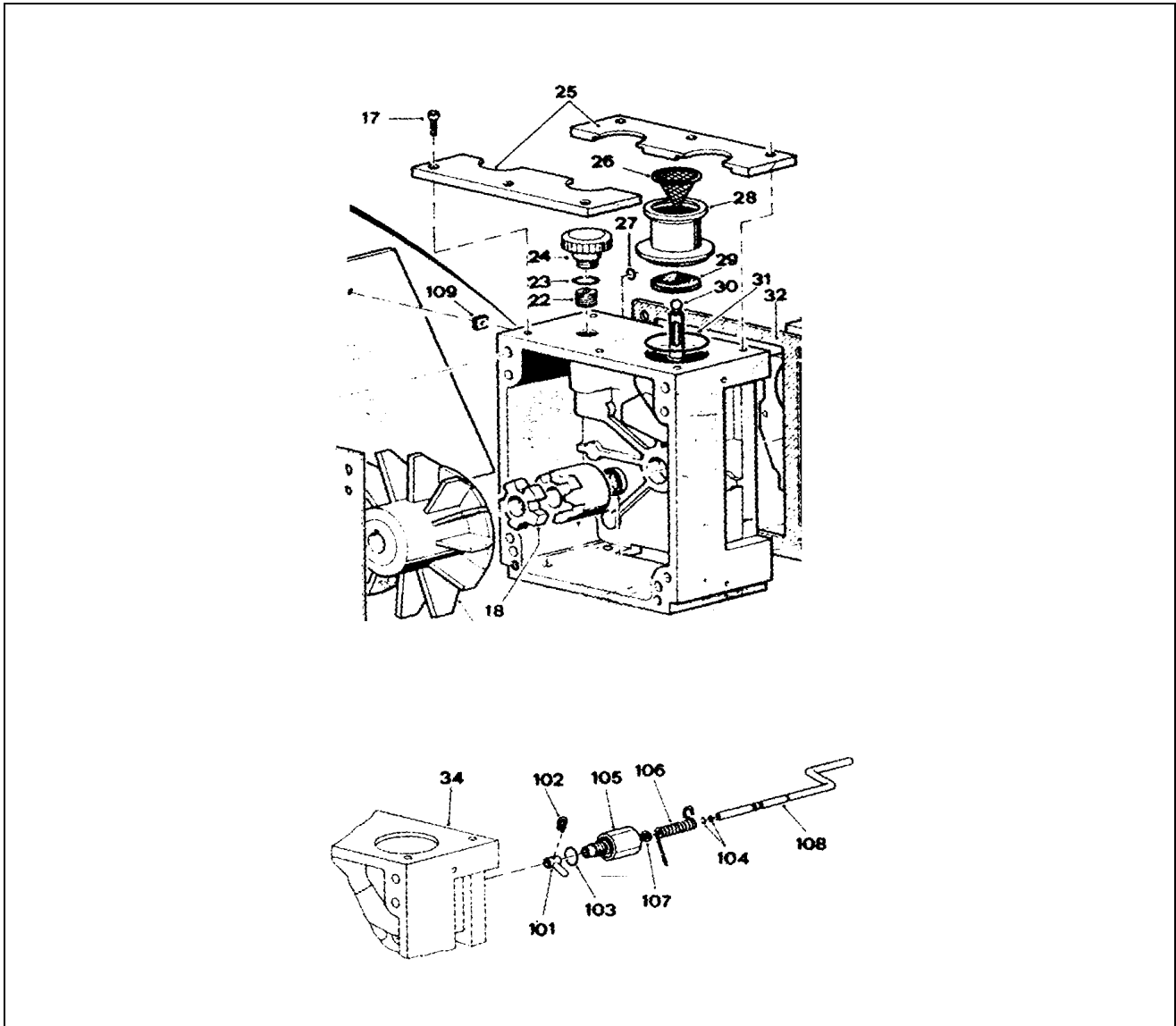

1. Disconnect the flange (28) from the inlet pipe line.
2. Remove the 6 securing screws (17) and remove the two half-plates (25) pressing the suction flange (28) into its seat.
3. Remove the flange (28) and take out the piston (30) with the shutter (29) of the anti-suckback device, disengage it by exerting force on arm (101). Separate the shutter (29) from the piston rod (30) simply by pulling.

 **CAUTION**

Be careful not to scratch the sealing surface of the shutter (29).

4. Reassemble by proceeding in the inverse order.

	Unscheduled Maintenance	Card No. <div style="border: 1px solid black; padding: 2px; width: fit-content; margin: 0 auto;">105</div>
---	--------------------------------	--

Pump type:	<div style="border: 1px solid black; padding: 2px;">DS102 1Ph, DS202 1Ph, DS302 1Ph, DS402 1Ph, DS402 3Ph, DS602 1Ph, DS602 3Ph</div>
-------------------	---

Frequency:	<div style="border: 1px solid black; padding: 2px;">WHEN DAMAGED</div>	Time:	<div style="border: 1px solid black; padding: 2px;">30 min.</div>	Machine status:	S	R
-------------------	--	--------------	---	------------------------	---	---

Type of action:	<div style="border: 1px solid black; padding: 2px;">REPLACEMENT</div>
Item:	<div style="border: 1px solid black; padding: 2px;">ELECTRIC MOTOR AND JOINT</div>

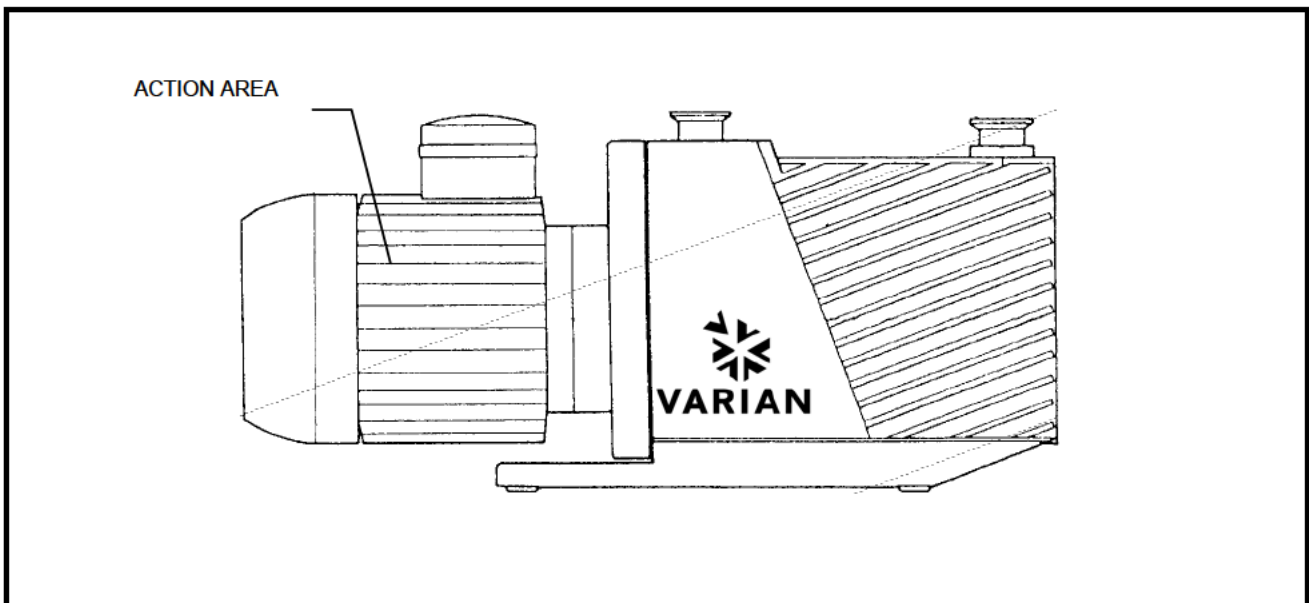

Materials required: <ul style="list-style-type: none"> • Electric motor 	Equipment required: <ul style="list-style-type: none"> • Mechanical tools
--	--

 **WARNING!**

Machine safety: disconnect all power lines. Hang the card "MACHINE UNDERGOING MAINTENANCE - DO NOT POWER ON" from the main breaker switch. When finished, remove the safety warning.

 **WARNING!**

If you have to perform maintenance on the pump after a considerable time in operation, leave it to cool as temperature of the outer surface may be in excess of 60 °C.

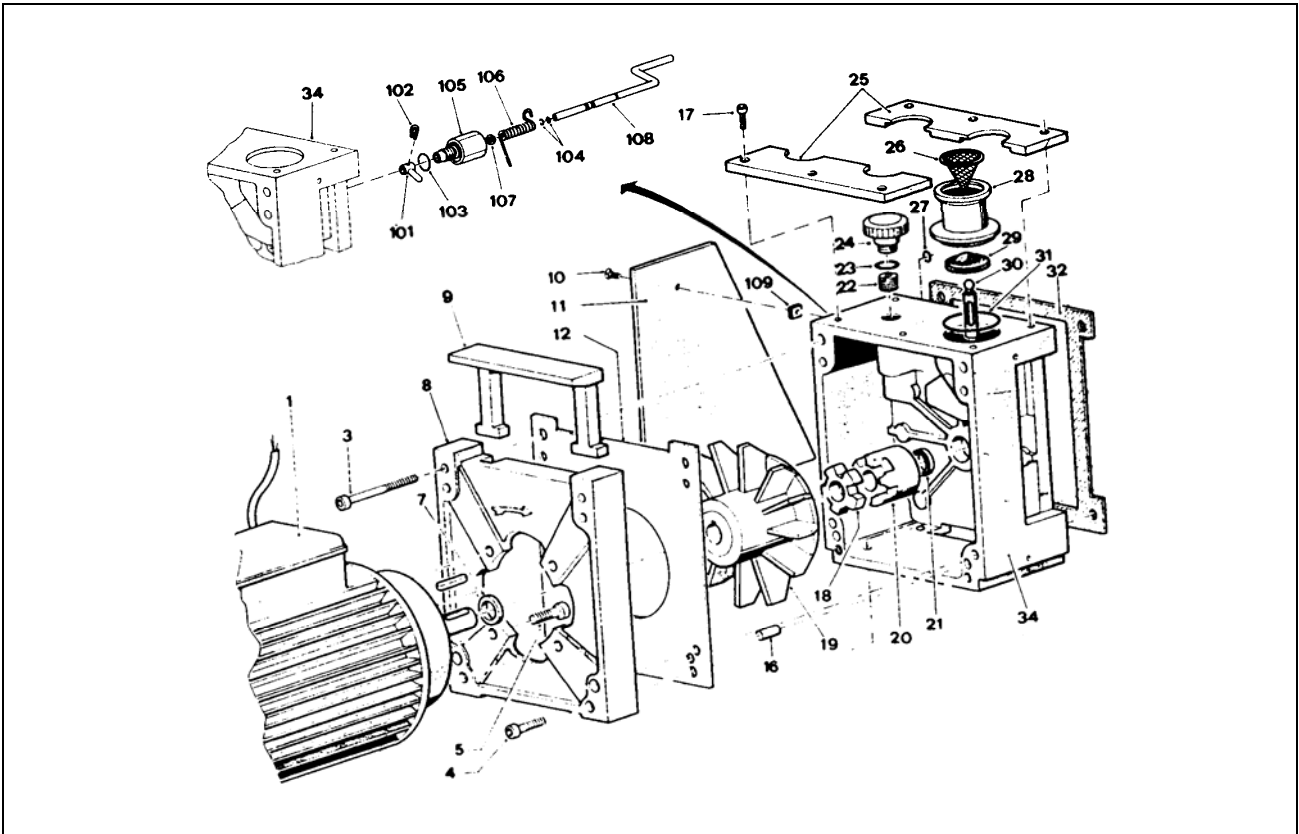

1. Disconnect the motor bearing plate (8) from the support (34) by removing the four screws (4).
2. Remove the half-joint/fan (19) from the support, together with the motor (1), the plate (8) and the plate (12) (for the DS402 1Ph, DS402 3Ph, DS602 1Ph and DS602 3Ph only).
3. Slacken the nut blocking the half-joint (19) to the motor shaft and take it out, using leverage between the plate (8) and the back of the joint.
4. Remove the four screws (5) and separate the plate (8) from the motor (1).
5. Reassemble by proceeding in the inverse order.

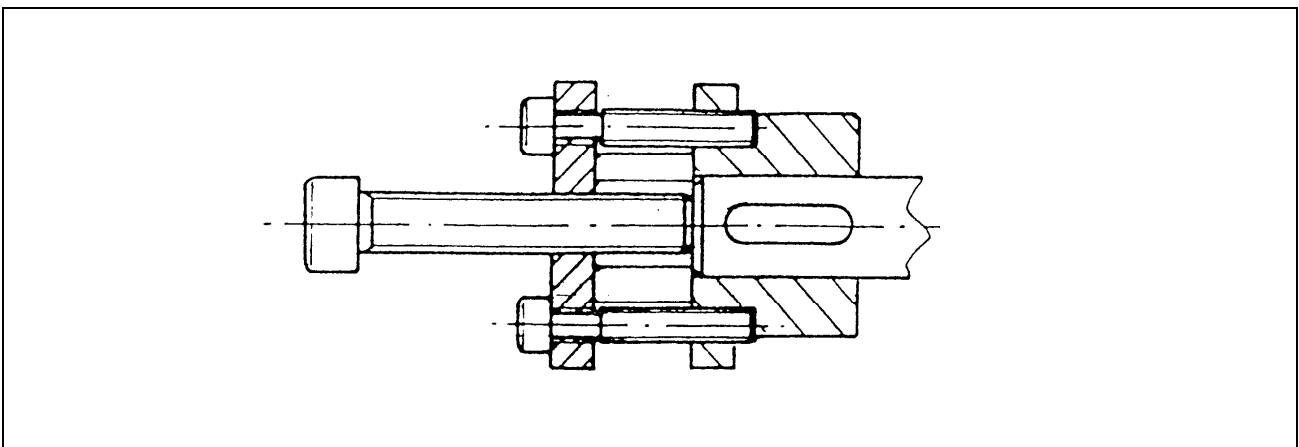

Extractor

	Unscheduled Maintenance	Card No. <div style="border: 1px solid black; padding: 2px; width: fit-content; margin: 0 auto;">106</div>
---	--------------------------------	--

Pump type:	<div style="border: 1px solid black; padding: 2px;">DS102 1Ph, DS202 1Ph, DS302 1Ph, DS402 1Ph, DS402 3Ph, DS602 1Ph, DS602 3Ph</div>
-------------------	---

Frequency:	<div style="border: 1px solid black; padding: 2px;">WHEN DAMAGED</div>	Time:	<div style="border: 1px solid black; padding: 2px;">1 hour</div>	Machine status:	<div style="display: inline-block; border: 1px solid black; padding: 2px; margin-right: 5px;">S</div> <div style="display: inline-block; border: 1px solid black; padding: 2px;">R</div>
-------------------	--	--------------	--	------------------------	--

Type of action:	<div style="border: 1px solid black; padding: 2px;">DISASSEMBLY</div>
Item:	<div style="border: 1px solid black; padding: 2px;">DISCHARGE VALVES</div>

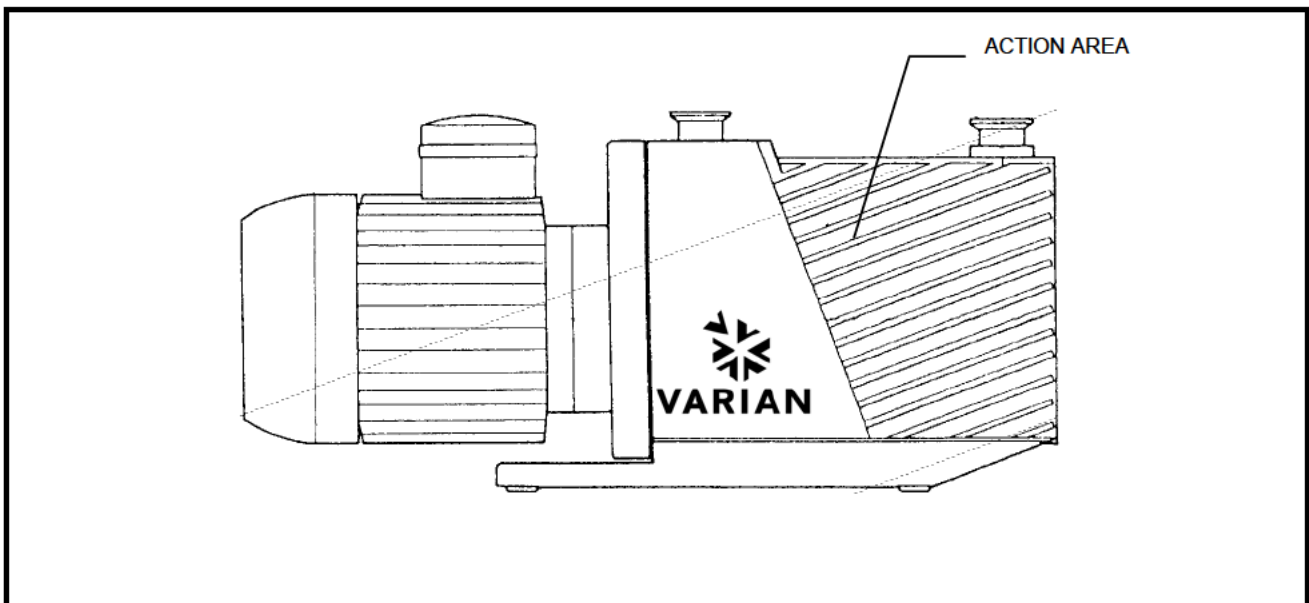

Materials required:	Equipment required:
<ul style="list-style-type: none"> • Valves (Gaskets kit) 	<ul style="list-style-type: none"> • Mechanical tools

 **WARNING!**

Machine safety: disconnect all power lines. Hang the card "MACHINE UNDERGOING MAINTENANCE - DO NOT POWER ON" from the main breaker switch. When finished, remove the safety warning.

 **WARNING!**

If you have to perform maintenance on the pump after a considerable time in operation, leave it to cool as temperature of the outer surface may be in excess of 60 °C.

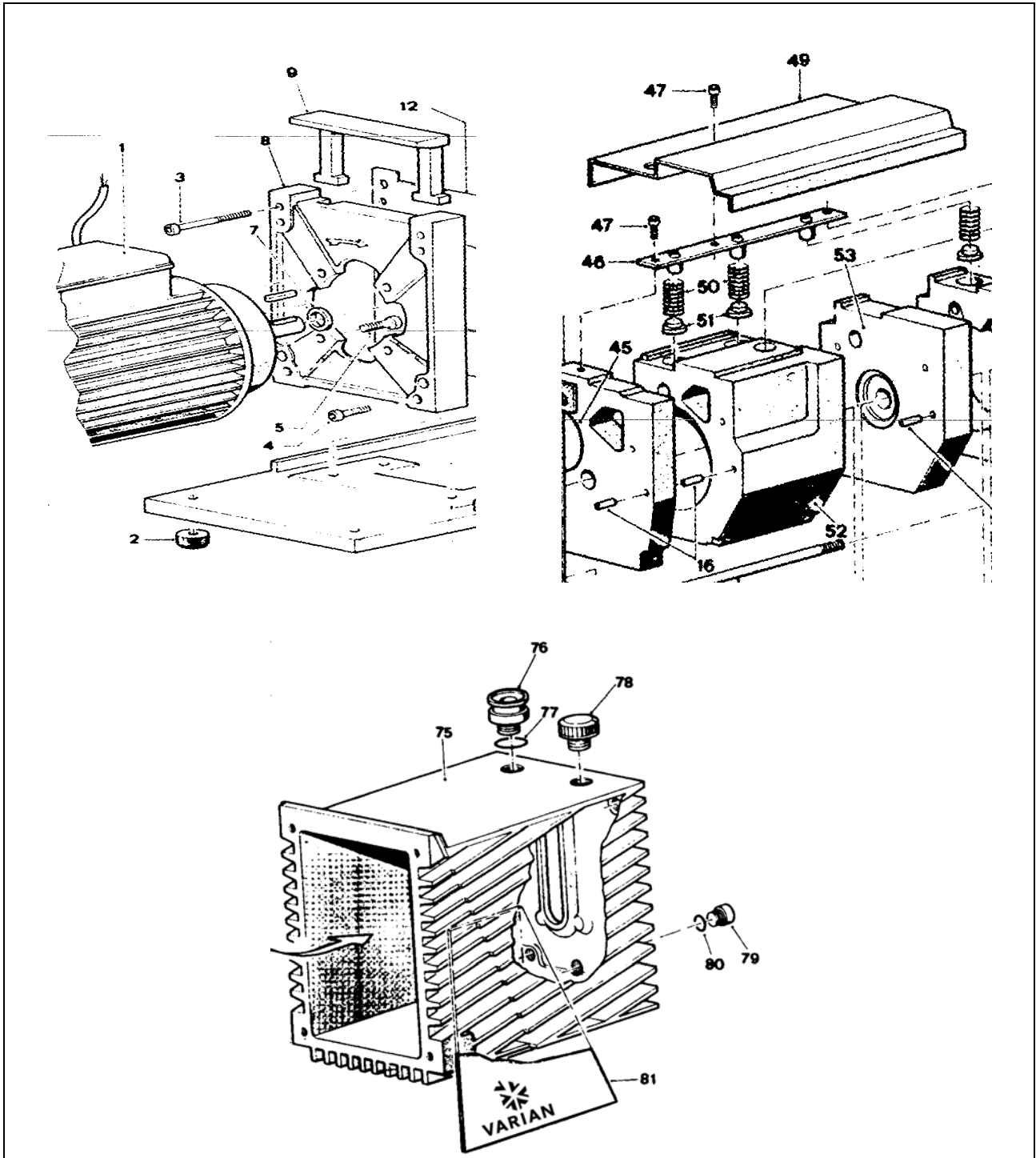

1. Drain off all the oil from the pump.

NOTE

For a description of how to drain off the oil, see the Unscheduled Maintenance Card No. 102.

2. Disconnect the discharge flange from its piping.
3. Remove the nuts (3) and remove the pump casing (75).
4. Remove the securing screw (47) holding the splash guard (49) and remove it.

5. Remove the two screws (47) on the valve press-bracket (46) and remove the bracket (46), the springs (50) and the shutters (51).
6. Reassemble by proceeding in the inverse order.

NOTE

When reassembling, replace all the gaskets stripped down.



CAUTION

When reassembly is complete, proceed to fill the pump with oil following the instructions of Unscheduled Maintenance Card No. 102.

	Unscheduled Maintenance	Card No. <div style="border: 1px solid black; padding: 2px; width: fit-content; margin: auto;">107</div>
---	--------------------------------	--

Pump type:	<div style="border: 1px solid black; padding: 2px;">DS102 1Ph, DS202 1Ph, DS302 1Ph, DS402 1Ph, DS402 3Ph, DS602 1Ph, DS602 3Ph</div>
-------------------	---

Frequency:	<div style="border: 1px solid black; padding: 2px;">WHEN DAMAGED</div>	Time:	<div style="border: 1px solid black; padding: 2px;">1 hour</div>	Machine status:	S	R
-------------------	--	--------------	--	------------------------	---	---

Type of action:	<div style="border: 1px solid black; padding: 2px;">DISASSEMBLY</div>
Item:	<div style="border: 1px solid black; padding: 2px;">OIL CIRCULATION PUMP 949-9390</div>

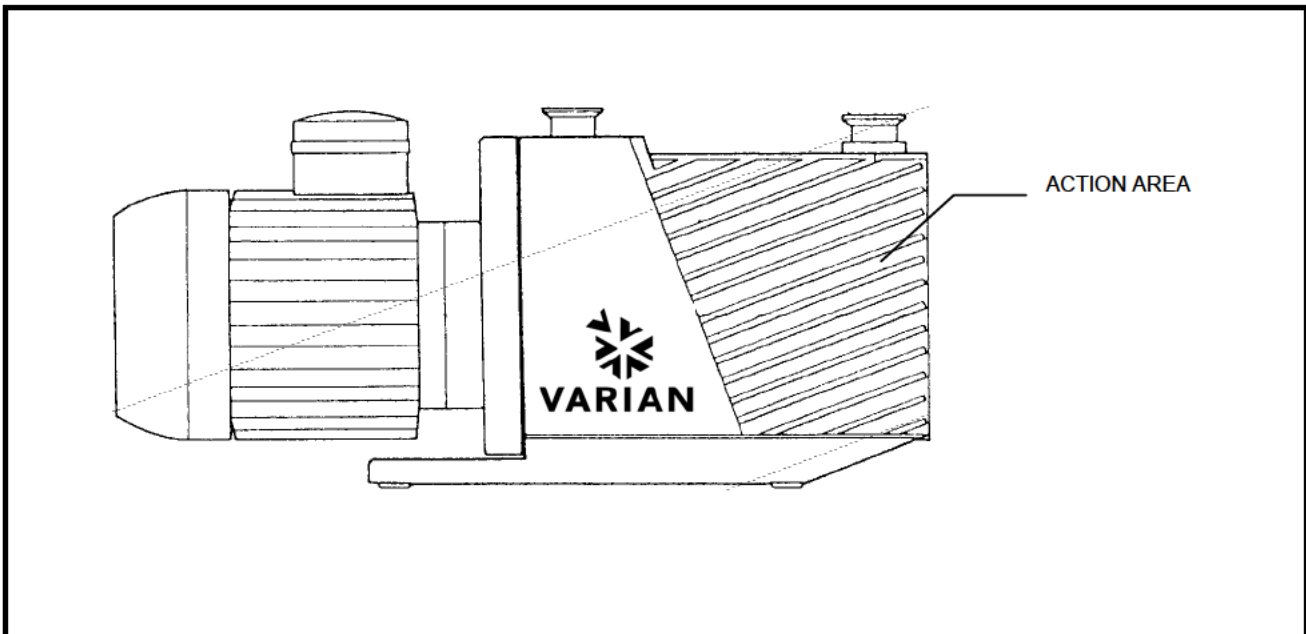

Materials required: <ul style="list-style-type: none"> • Oil circulating pump P/N 949-9390 	Equipment required: <ul style="list-style-type: none"> • Mechanical tools
---	--

 **WARNING!**

Machine safety: disconnect all power lines. Hang the card "MACHINE UNDERGOING MAINTENANCE - DO NOT POWER ON" from the main breaker switch. When finished, remove the safety warning.

 **WARNING!**

If you have to perform maintenance on the pump after a considerable time in operation, leave it to cool as temperature of the outer surface may be in excess of 60 °C.

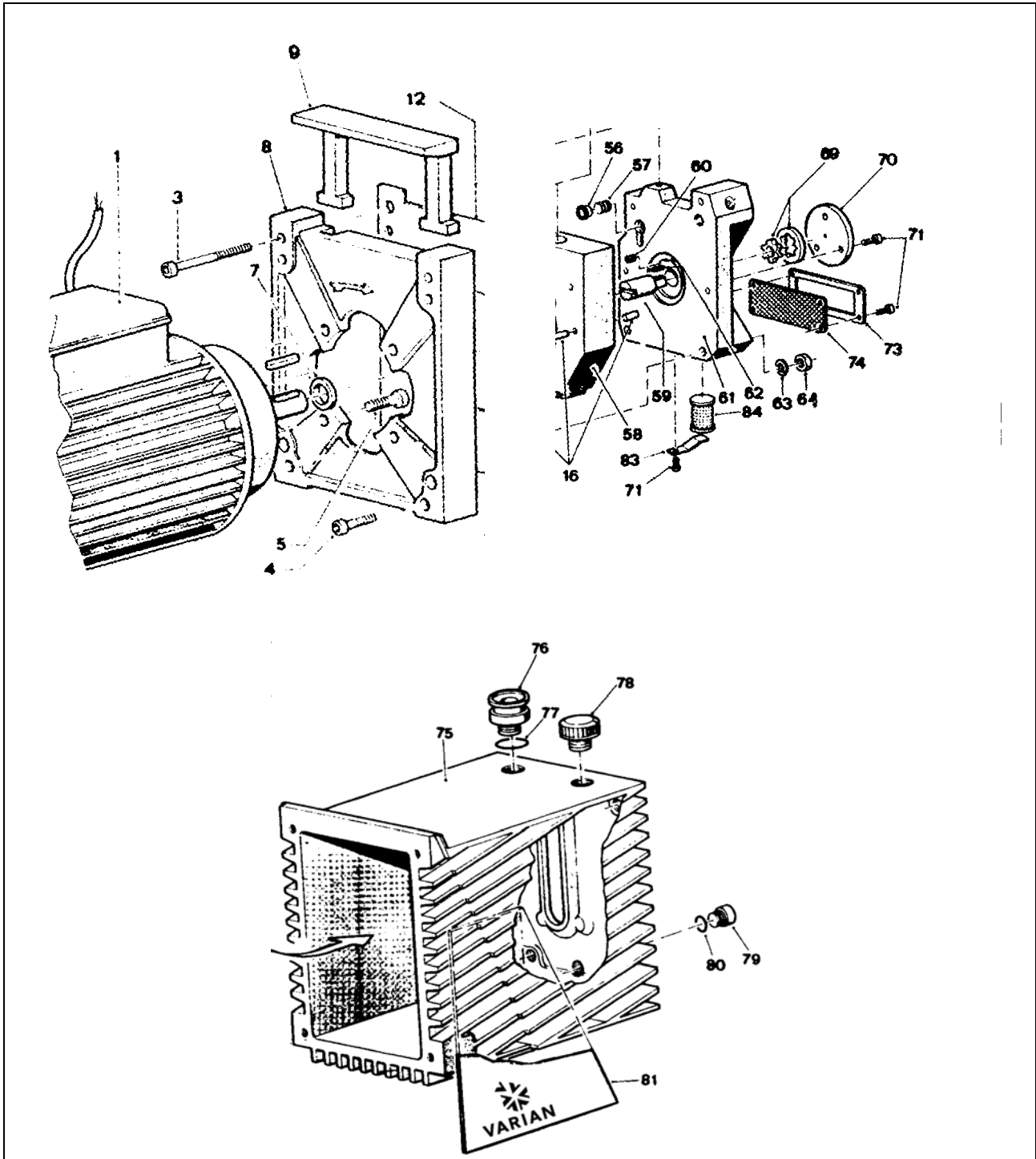

1. Drain off all the oil from the pump.

NOTE

For a description of how to drain the oil from the pump, see the Unscheduled Maintenance Card No. 102.

2. Disconnect the discharge flange from its piping.
3. Remove the nuts (3) and remove the casing from the pump (75).
4. Remove the three screws (71) connecting the closing plate (70) to the side and take it out.
5. Remove the pump gear-wheels (69).

NOTE

A magnet may be used to remove the gear-wheels.

6. Reassemble by proceeding in the inverse order.

NOTE

When reassembling, replace all the gaskets you have stripped down.



CAUTION

When reassembly is complete, proceed to fill the pump with oil again following the instructions of Unscheduled Maintenance Card No. 102.

	Unscheduled Maintenance	Card No. <div style="border: 1px solid black; padding: 2px; width: fit-content; margin: 0 auto;">108</div>
---	--------------------------------	--

Pump type:	<div style="border: 1px solid black; padding: 2px;">DS102 1Ph, DS202 1Ph, DS302 1Ph, DS402 1Ph, DS402 3Ph, DS602 1Ph, DS602 3Ph</div>
-------------------	---

Frequency:	<div style="border: 1px solid black; padding: 2px;">WHEN DAMAGED</div>	Time:	<div style="border: 1px solid black; padding: 2px;">1 hour</div>	Machine status:	S	R
-------------------	--	--------------	--	------------------------	---	---

Type of action:	<div style="border: 1px solid black; padding: 2px;">DISASSEMBLY</div>
Item:	<div style="border: 1px solid black; padding: 2px;">ANTI-SUCKBACK DEVICE</div>

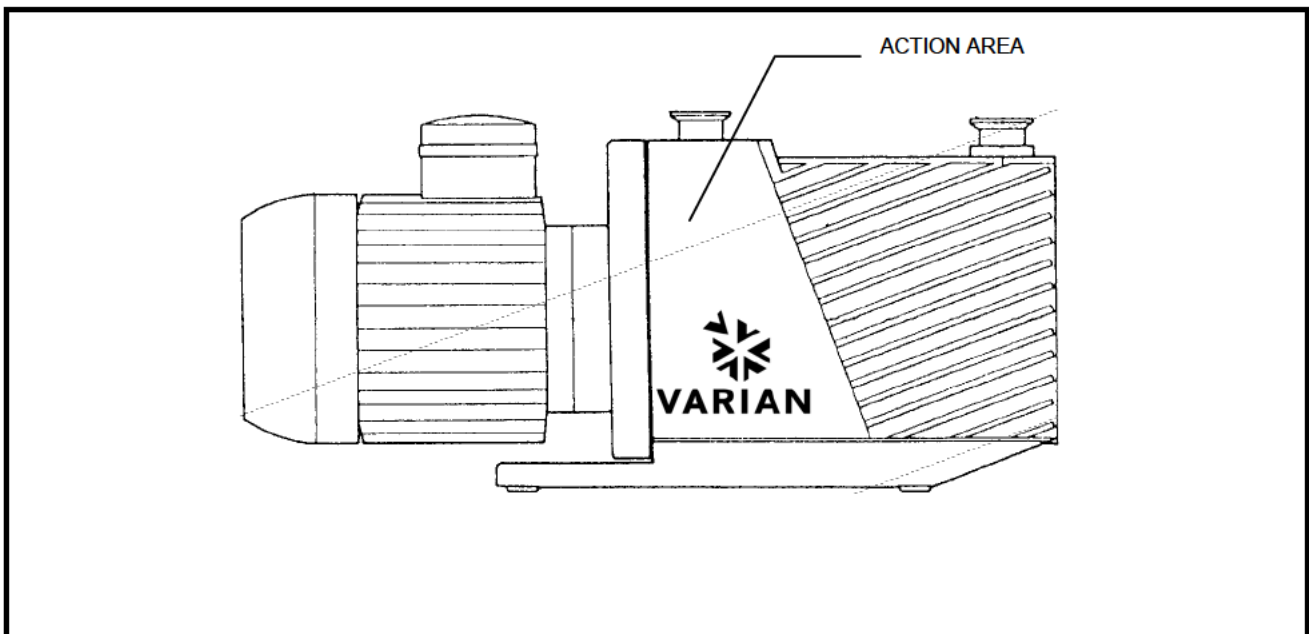

Materials required:	Equipment required:
<ul style="list-style-type: none"> • Gaskets kit 	<ul style="list-style-type: none"> • Mechanical

 **WARNING!**

Machine safety: disconnect all power lines. Hang the card "MACHINE UNDERGOING MAINTENANCE - DO NOT POWER ON" from the main breaker switch. When finished, remove the safety warning.

 **WARNING!**

If you have to perform maintenance on the pump after a considerable time in operation, leave it to cool as temperature of the outer surface may be in excess of 60 °C.

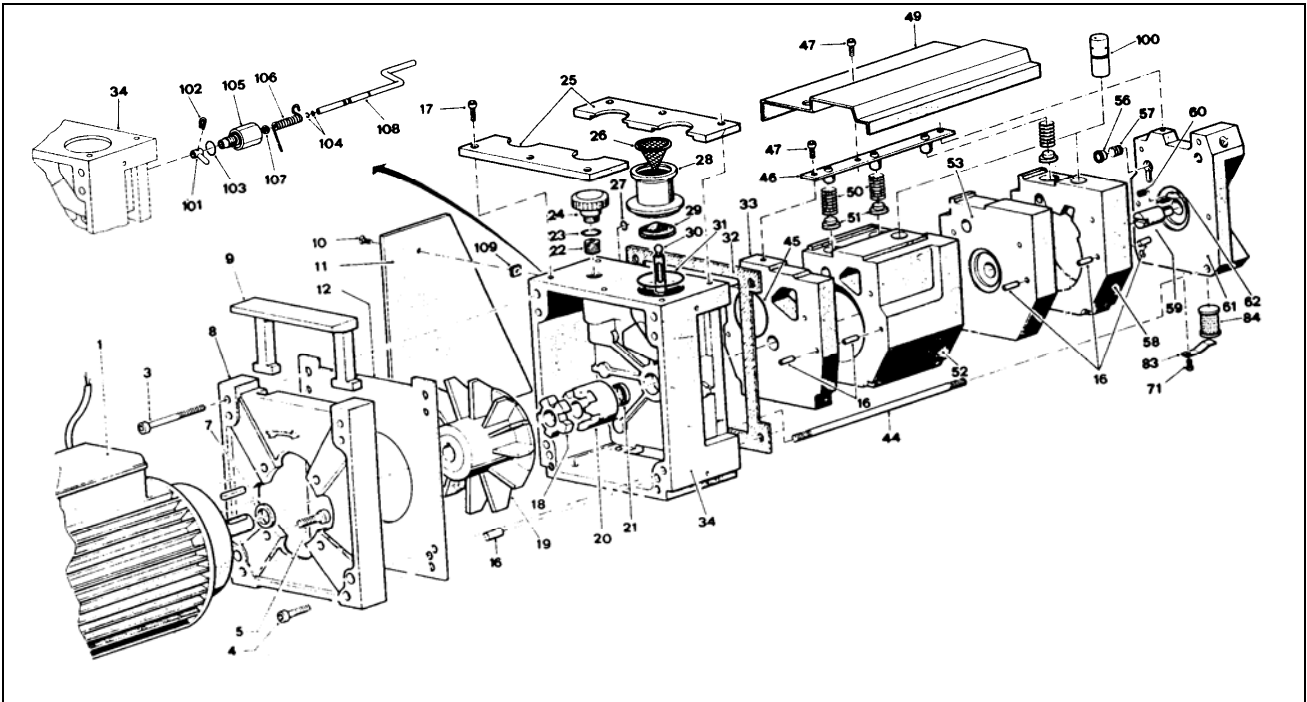

1. Drain off all the oil from the pump.

NOTE

For a description of how to drain the oil, see the Unscheduled Maintenance Card No. 102.

2. Disconnect the discharge flanges from their piping.
3. Remove the locking nuts (3) and remove the casing (75) from the pump.
4. Remove the securing screw (47) and remove the splash guard (49).
5. Remove the shutter from the anti-suckback device.

NOTE

For more details on how to remove the anti-suckback device, see Unscheduled Maintenance Card No. 104.

6. Remove the screw (102), take out the arm (101) from the rod.
7. Release the spring (106) from the rod arm (108).
8. Pull the rod (108) out of the rotary feedthrough (105) sleeve.
9. Remove the two OR gaskets (104) from the rod (108) using a screwdriver, if necessary. Be careful not to bend the rod in doing so.
10. Remove the sleeve (105) and remove it from the support (34) together with its OR gasket (103).
11. Remove the hydraulic piston (100) from its seat in the body.
12. Reassemble by proceeding in the inverse order.

NOTE

When reassembling, replace all the gaskets stripped down.

 **CAUTION**

When reassembly is complete, proceed to fill the pump with oil again following the instructions of Unscheduled Maintenance Card No. 102.

VARIAN  <i>vacuum technologies</i>	Unscheduled Maintenance	Card No. <div style="border: 1px solid black; padding: 2px; width: fit-content; margin: 0 auto;">109</div>
---	--------------------------------	--

Pump type:	DS102 1Ph, DS202 1Ph, DS302 1Ph, DS402 1Ph, DS402 3Ph, DS602 1Ph, DS602 3Ph
-------------------	---

Frequency:	WHEN DAMAGED	Time:	1 hour	Machine status:	<div style="border: 1px solid black; padding: 2px; display: inline-block;">S R</div>
-------------------	--------------	--------------	--------	------------------------	--

Type of action:	DISASSEMBLY
Item:	PUMP BODY

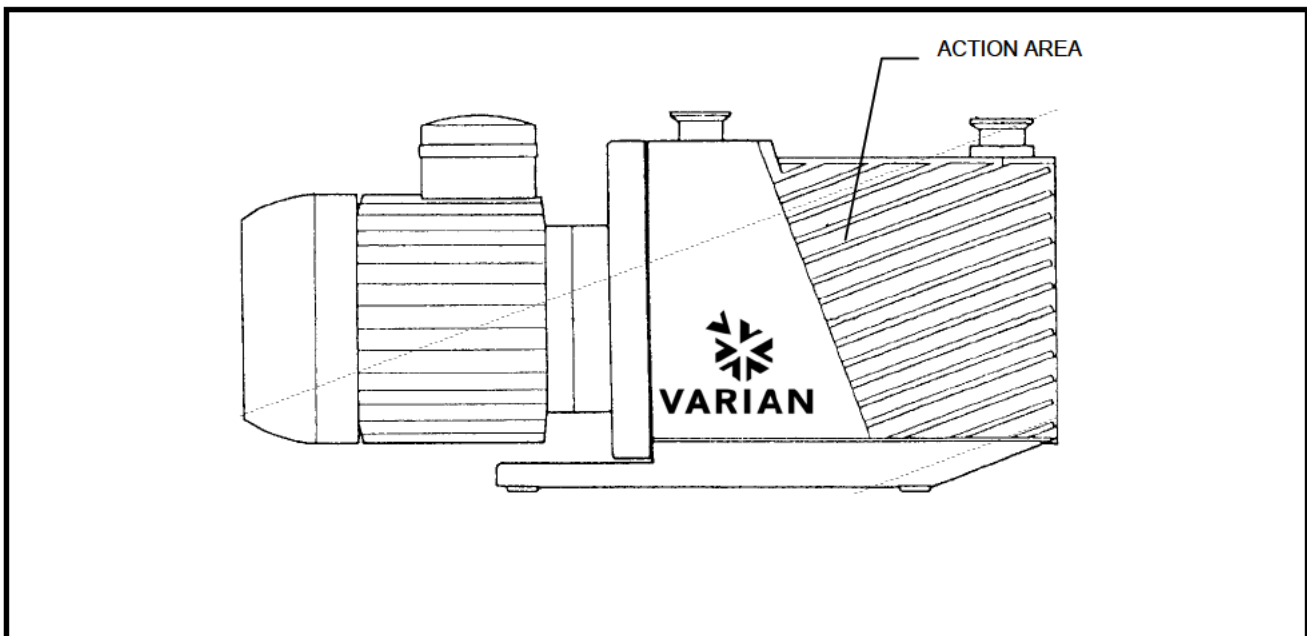

Materials required:	Equipment required:
<ul style="list-style-type: none"> • Gaskets kit 	<ul style="list-style-type: none"> • Mechanical tools

 **WARNING!**

Machine safety: disconnect all power lines. Hang the card "MACHINE UNDERGOING MAINTENANCE - DO NOT POWER ON" from the main breaker switch. When finished, remove the safety warning.

 **WARNING!**

If you have to perform maintenance on the pump after a considerable time in operation, leave it to cool as temperature of the outer surface may be in excess of 60 °C.

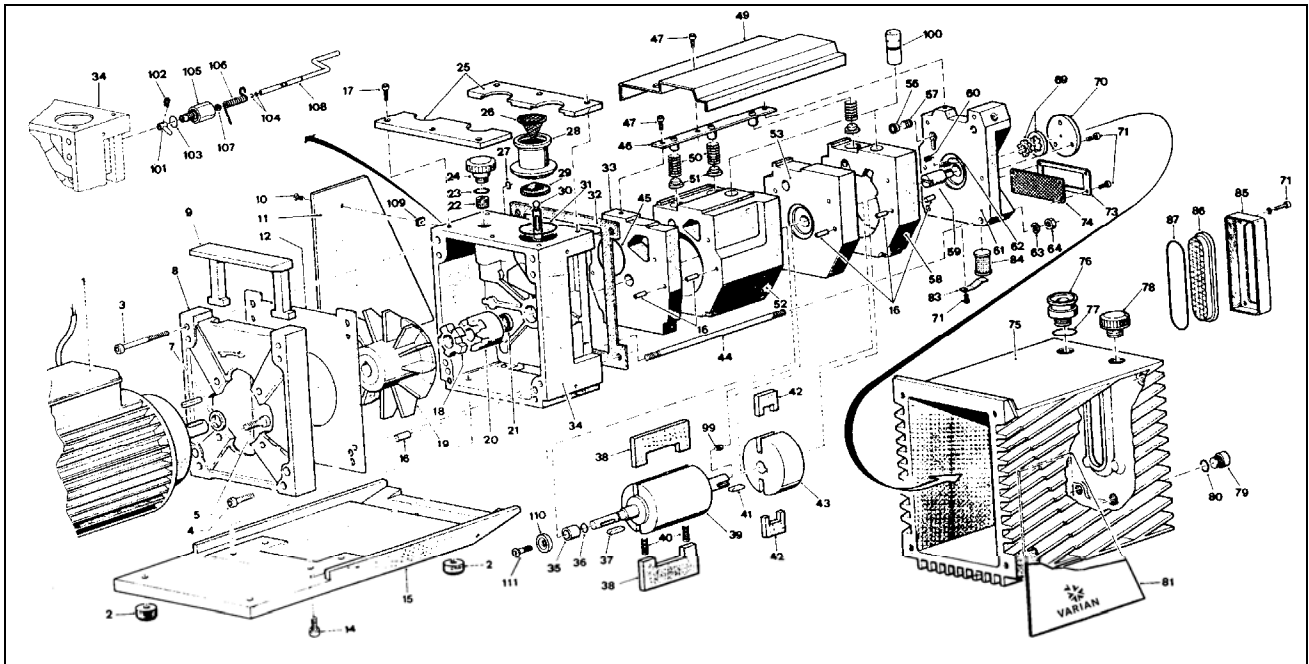

1. Drain off all the oil from the pump.

NOTE

For a description of how to drain off the oil, see the Unscheduled Maintenance Card No. 102.

2. Disconnect the discharge flange from its piping.
3. Disconnect the electric motor (1) complete with half-joint.

NOTE

For a description of how to disassemble the electric motor, see the Unscheduled Maintenance Card No. 105.

4. (On DS402 1Ph, DS402 3Ph, DS602 1Ph and DS602 3Ph: remove the screw (111) and remove the seal (110)). Slacken the nut locking the half-joint (20) to the shaft of the rotor (39) and take out the half-joint. Remove the tongue (37) with it as well.
5. Unscrew the securing screw (47) and remove the valve screen (49).
6. Slacken the four nuts (64) and take out the tie-rods (44) and the complete functional block (76), lifting it from the pump support (34) and take out the OR gaskets (27) and (45), from the gas ballast line and suction line respectively.

CAUTION

Be careful not to cut the lip of the oil seal with the sharp edges of the shaft key seat.

7. Reassemble by proceeding in the inverse order.

NOTE

When reassembling, replace all the gaskets stripped down.

CAUTION

When reassembly is complete, proceed to fill the pump with oil again following the instructions of Unscheduled Maintenance Card No. 102.

	Unscheduled Maintenance	Card No. <div style="border: 1px solid black; padding: 2px; width: fit-content; margin: 0 auto;">110</div>
---	--------------------------------	--

Pump type:	DS402 1Ph, DS402 3Ph, DS602 1Ph, DS602 3Ph
-------------------	--

Frequency:	WHEN DAMAGED	Time:	1 hour and 15 min.	Machine status: S R
-------------------	--------------	--------------	--------------------	--

Type of action:	REPLACEMENT
Item:	OIL SHAFT SEAL / ANTI-WEAR BUSHING

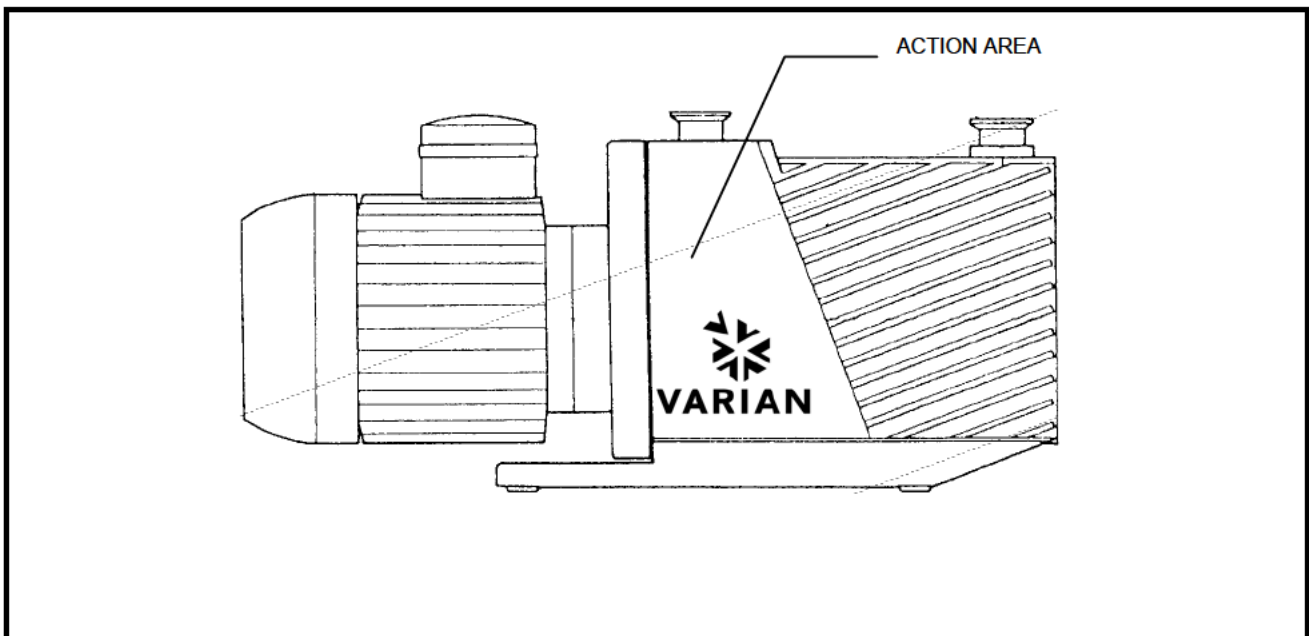

Materials required: <ul style="list-style-type: none"> • Oil shaft seal • Anti-wear bushing • Gaskets kit 	Equipment required: <ul style="list-style-type: none"> • Mechanical tools
---	---

 **WARNING!**

Machine safety: disconnect all power lines. Hang the card "MACHINE UNDERGOING MAINTENANCE - DO NOT POWER ON" from the main breaker switch. When finished, remove the safety warning.

 **WARNING!**

If you have to perform maintenance on the pump after a considerable time in operation, leave it to cool as temperature of the outer surface may be in excess of 60 °C.

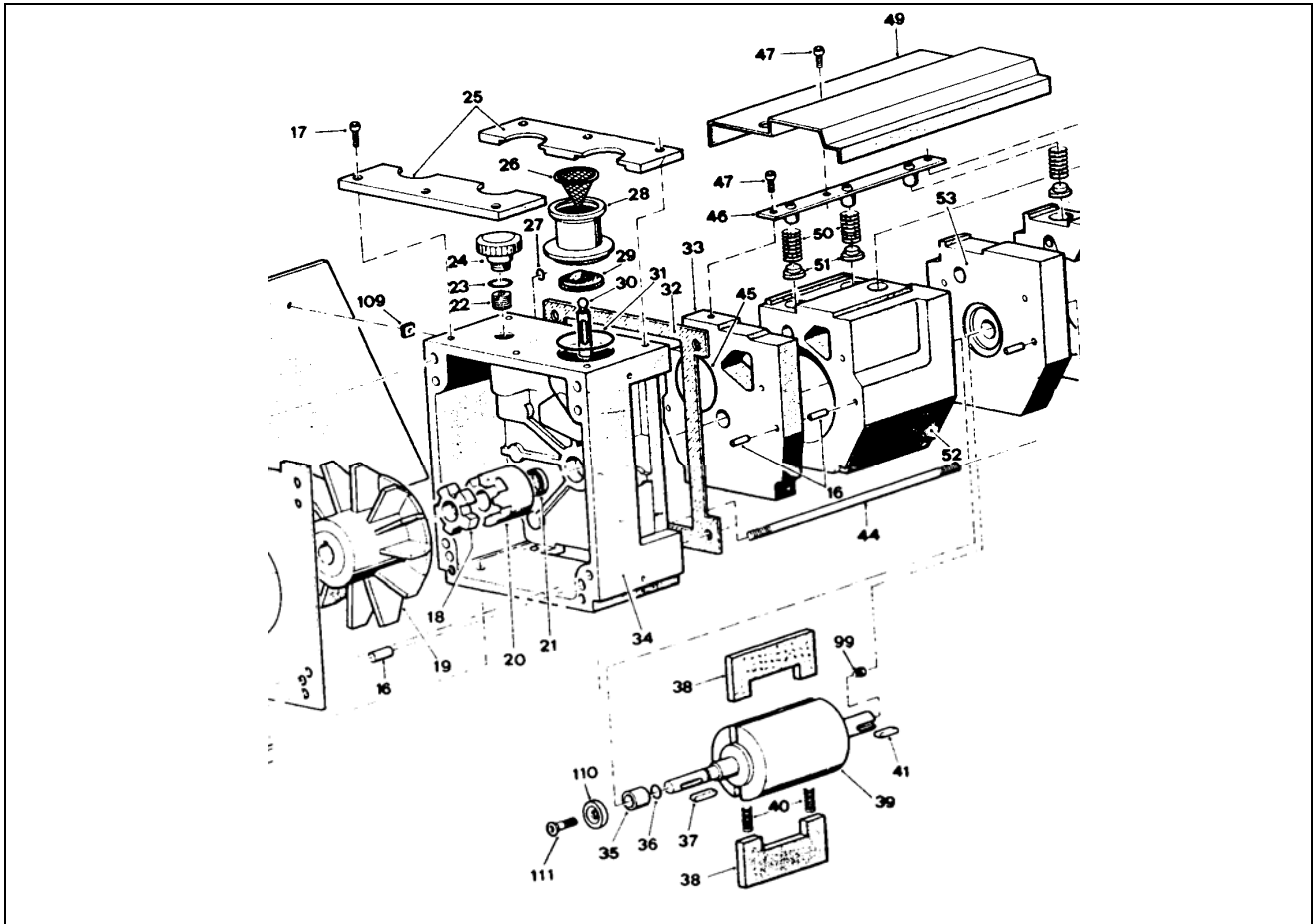

1. Drain off all the oil from the pump.

NOTE

For a description of how to drain off the oil, see the Unscheduled Maintenance Card No. 102.

2. Separate the functional block from the pump support.

NOTE

For a description of how to separate the functional block from the support, see the Unscheduled Maintenance Card No. 109.

3. Remove the worn out oil shaft seal (21) from the pump support (34) using a screwdriver for leverage and taking care not to scratch the seat.
4. Take the anti-wear bushing (35) off the shaft and take out the OR Gasket (36).

NOTE

For assembly of the new oil shaft seal, a special tool is needed.

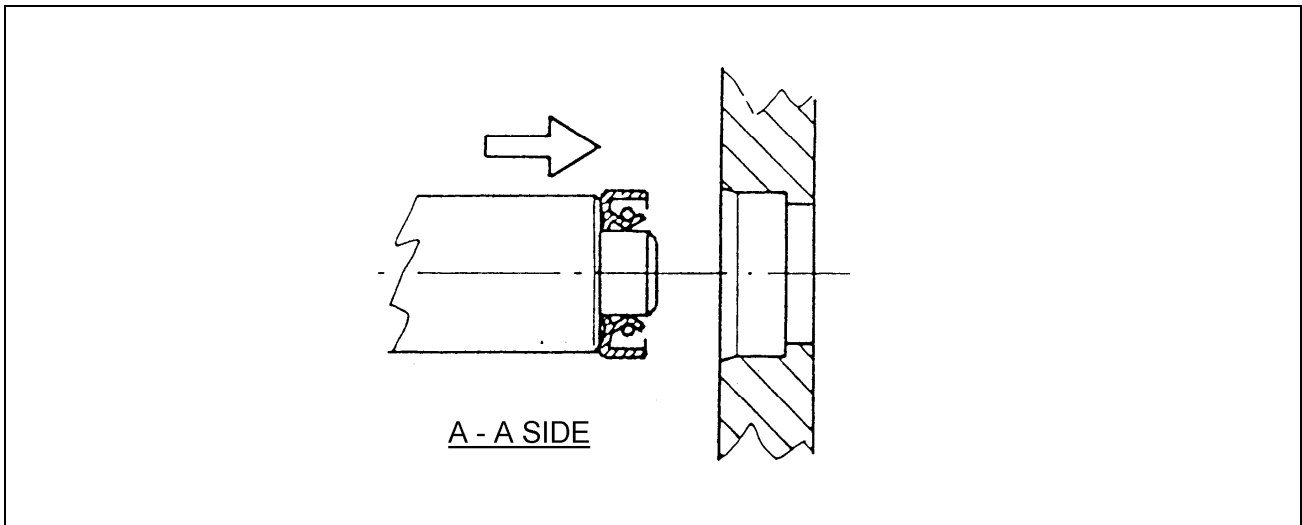

5. After applying silicone grease to the external diameter of the oil seal, engage it on the tool and push it into its seat.
6. Reassemble by proceeding in the inverse order.

NOTE

When reassembling, replace all the gaskets stripped down.

 **CAUTION**

When reassembly is complete, proceed to fill the pump with oil again following the instructions of Unscheduled Maintenance Card No. 102.

	Unscheduled Maintenance	Card No. <div style="border: 1px solid black; padding: 2px; width: fit-content; margin: 0 auto;">111</div>
---	--------------------------------	--

Pump type:	<div style="border: 1px solid black; padding: 2px;">DS102 1Ph, DS202 1Ph, DS302 1Ph, DS402 1Ph, DS402 3Ph, DS602 1Ph, DS602 3Ph</div>
-------------------	---

Frequency:	<div style="border: 1px solid black; padding: 2px;">WHEN DAMAGED</div>	Time:	<div style="border: 1px solid black; padding: 2px;">2 hours</div>	Machine status:	S	R
-------------------	--	--------------	---	------------------------	---	---

Type of action:	<div style="border: 1px solid black; padding: 2px;">DISASSEMBLY</div>
Item:	<div style="border: 1px solid black; padding: 2px;">FUNCTIONAL BLOCK ROTORS</div>

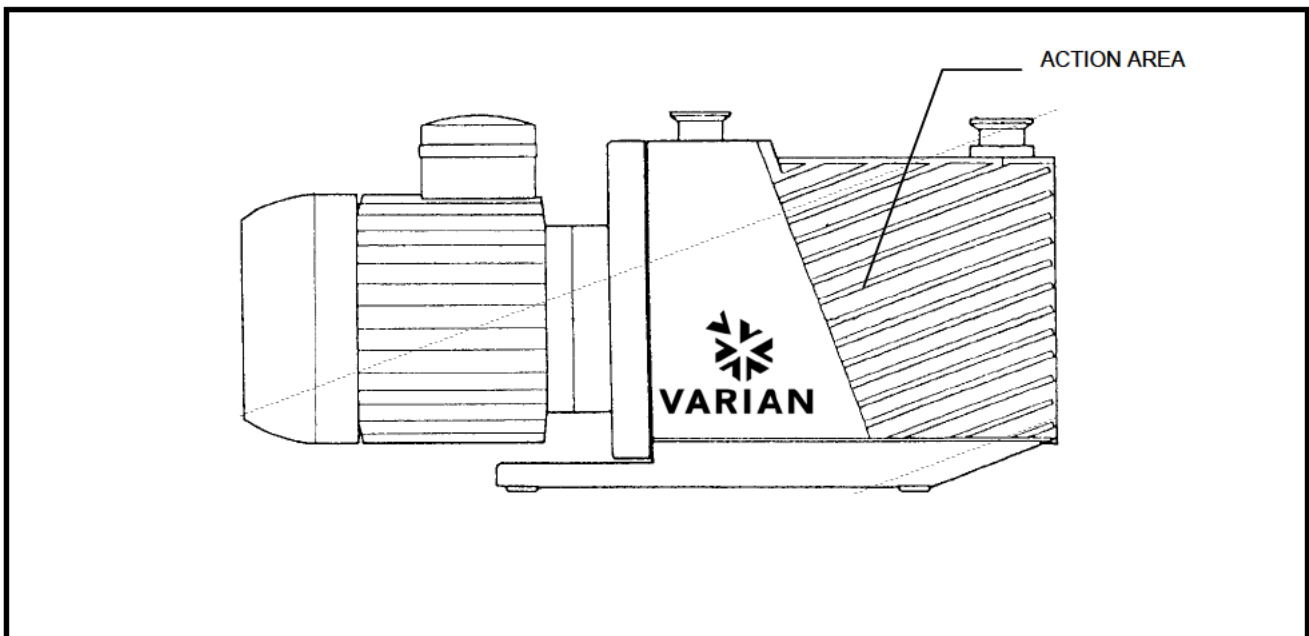

Materials required:	Equipment required:
<ul style="list-style-type: none"> • Oil shaft seal ring • Anti-wear bushing • OR gaskets • 1st stage vanes • 2nd stage vanes • Gas Ballast shutter <p>(the above items of material are included in the Major Maintenance kit)</p>	<ul style="list-style-type: none"> • Mechanical tools

! WARNING!

Machine safety: disconnect all power lines. Hang the card "MACHINE UNDERGOING MAINTENANCE - DO NOT POWER ON" from the main breaker switch. When finished, remove the safety warning.

! WARNING!

If you have to perform maintenance on the pump after a considerable time in operation, leave it to cool as temperature of the outer surface may be in excess of 60 °C.

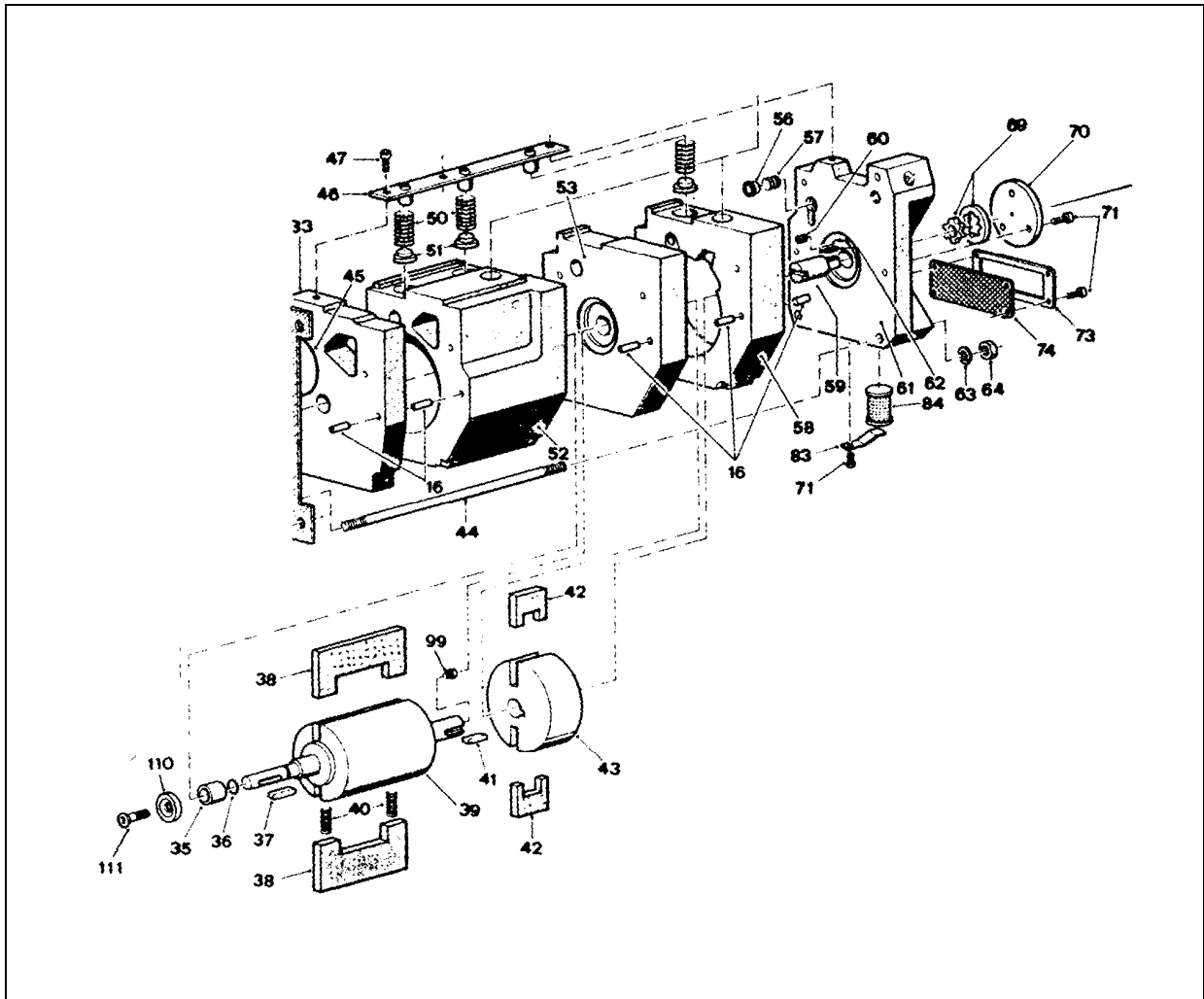

1. Drain off all the oil from the pump.

NOTE

For a description of how to drain the oil from the pump, see the *Unscheduled Maintenance Card No. 102*.

2. Detach the entire functional block from the pump support.

NOTE

For a description of how to detach the functional block, see the *Unscheduled Maintenance Card No. 109*.

3. Disassemble the discharge valves.

NOTE

*For a description of how to disassemble the discharge valves, see the **Unscheduled Maintenance Card No. 106.***

4. Detach the end plate (61) from the rest of the pump body, exerting leverage if necessary on the reference notches between the parts. This will give you access to the retaining valve (56) and associated spring (57) at the gas ballast inlet.
5. Disconnect the 2nd stage stator (58), remove the two vanes (42), take the 2nd stage rotor (43) off the shaft and take out the key (41).
6. Remove the partition wall (53) from between the 1st and 2nd stages.
7. Detach the 1st stage stator (52) from the inner side (33), pressing back on the springs (40) of the vanes (38) to avoid the vanes from touching against the sharp corners of the body and becoming damaged.
8. Take out the 1st stage rotor (39), the vanes (38) and the springs (40).
9. Reassemble by proceeding in the inverse order.

NOTE

When reassembling, replace all the gaskets stripped down.



CAUTION

After reassembly is complete, proceed to fill the pump again with oil following the instructions of **Unscheduled Maintenance Card No. 102.**

TROUBLESHOOTING AND CORRECTIVE ACTION

NOTE

If the pump breaks down or does not work well, first check thoroughly that all the standards rules listed in the sections relevant installation and operation are currently observed.

If you cannot get sufficiently low pressure, the problem may lie with the system connected to the pump, i.e. the vacuum chamber and inlet line.

Even when the design sizes are correct, the problems listed below are still fairly frequent:

- a) faulty seals: check that the seals are fitted, are in good working order and are clean; check all joints, taps, sight glasses, weld joints, etc.*
- b) unsuitable materials: avoid the use of rubber, plastic or even metal parts that are porous or permeable.*
- c) volatile substances: as far as possible, eliminate humidity, grease, dirt, rust, solvents (even small traces).*

	SYMPTOM	PROBABLE CAUSE	SUGGESTED REMEDY	CARD REF.
1	The pump does not start (or stops immediately).	A) The motor-pump coupling is defective.	Check state of the elastic joint and replace the parts as needed.	105
		B) Viscosity of the oil has increased.	Examine the oil and change if necessary (find out why it has deteriorated).	102
		C) Excessive friction inside pump.	Test the resistance to rotation, by turning the joint by hand. If the rotors are blocked, disassemble the pump body and check state of the parts inside.	111
		D) Electrical protections not set.	Adjust the protections.	
		E) Oil too viscous because of low room temperature.	Heat the oil up to a temperature of 20 °C or use an oil recommended for low temperatures.	102
		F) Direction of rotation inverted (only 3-phase motors).	Change over two phase wires of the electric power supply.	
2	The pump stops (stalls).	A) Seizure of some internal parts.	Proceed as at 1-C.	
		B) Oil very dirty.	Proceed as at 1-B.	
3	The pump overheats.	A) Too much friction inside.	Proceed as at 1-C.	
		B) Oil ducts clogged inside.	Try changing the oil, otherwise disassemble the pump and clean it well.	102 111
4	Too much oil drained off by the exhaust.	A) Gas Ballast device broken (always open).	Check the device to ensure the gas ballast is properly adjusted.	111
		B) Heavy duty work (high suction pressures or very frequent cycles).	Check condition of the oil trap filter.	
		C) Leak in system.	Check the system (see "Note").	
5	The pump is loosing oil.	A) Seal on shaft defective.	Replace the oil seal and the anti-wear bushing.	110
		B) Other gaskets defective.	Identify the areas where seeping occurs and check the associated gaskets.	Refer to the card related to involved item
		C) Oil level window broken	Replace the oil level window.	

	SYMPTOM	PROBABLE CAUSE	SUGGESTED REMEDY	CARD REF.
6	The pump is very noisy even at steady operating conditions.	A) Exhaust valves damaged.	Inspect the valves.	106
		B) High suction pressure, or gas ballast device is open.	Check the system and the gas ballast valve (see items 4-A and 4-B).	
		C) Elastic star of joint is damaged.	Check and replace if necessary.	
		D) A screw of the joint has become loose.	Lock the screw after application of Loctite 222 (for slack threads).	
7	When the pump is stopped, the inlet pressure rises rapidly.	A) The anti-suckback device is defective.	Disassemble and check the anti-suckback device.	108
		B) The cause of the problem is not with the pump.	See "Note".	
8	The pump does not produce a sufficient vacuum.	A) Not enough oil, or oil contaminated.	Check level and appearance of the oil. Open the Gas Ballast for half an hour at least; change the oil whenever necessary.	01 102
		B) Oil ducts clogged inside.	Proceed as at 3-B.	
		C) Direction of rotation inverted.	Proceed as at 3-C.	
		D) OR gaskets communicating with the inlet line defective.	Replace the gaskets.	109
		E) Exhaust valves damaged or out of place.	Proceed as at 6-A.	
		F) Insufficient oil pressure in the lubricating circuit, preventing the anti-suckback device from opening.	Inspect the gears of the oil pump and check that it is working.	107
		G) Internal moving parts worn.	Disassemble the pump, and replace any worn parts.	111
		H) Pump working with gas ballast device open.	Close the gas ballast device.	
		I) Anti-suckback valve fails to open.	Disassemble the suction flange and check the device.	104 108
		J) Parts of the functional block not in perfect contact because of deposits of dirt or failure to put a plug on the service holes.	Disassemble and check condition of the part surfaces and that plugs have been used.	111
		K) The cause of the problem is not with the pump.	See "Note".	

SPARE PARTS LIST

OTHER SPARE PARTS	Q.TY					P/N
	DS102 1Ph	DS202 1Ph	DS302 1Ph	DS402 1Ph DS402 3Ph	DS602 1Ph DS602 3Ph	
MINOR MAINTENANCE KIT (*)	X	X	X			949-9370
MINOR MAINTENANCE KIT (*)				X	X	949-9371
MAJOR MAINTENANCE KIT (**)	X					949-9380
MAJOR MAINTENANCE KIT (**)		X	X			949-9381
MAJOR MAINTENANCE KIT (**)				X	X	949-9382

ACCESSORY ITEM ON EXHAUST	Q.TY					P/N
	DS102 1Ph	DS202 1Ph	DS302 1Ph	DS402 1Ph DS402 3Ph	DS602 1Ph DS602 3Ph	
OIL MIST ELIMINATOR KF25	X	X	X	X	X	949-9395
OIL MIST CARTRIDGE (Q.ty 2)	X	X	X	X	X	949-9394

RECOMMENDED OIL	P/N	Q.TY
Varian Rotary Vane Fluid DS19 Type (Europe)	949-9390	1 liter
Varian Rotary Vane Fluid DS19 Type (USA)	K7516301	1 liter
Varian Rotary Vane Fluid DS19 Type (USA)	K7516302	1 gallon

(*) Contains all the valves, O-rings and seals to refurbish the pump to vacuum integrity.

(**) Includes all the items of the minor maintenance kit plus the vanes.