

1.855.882.2886

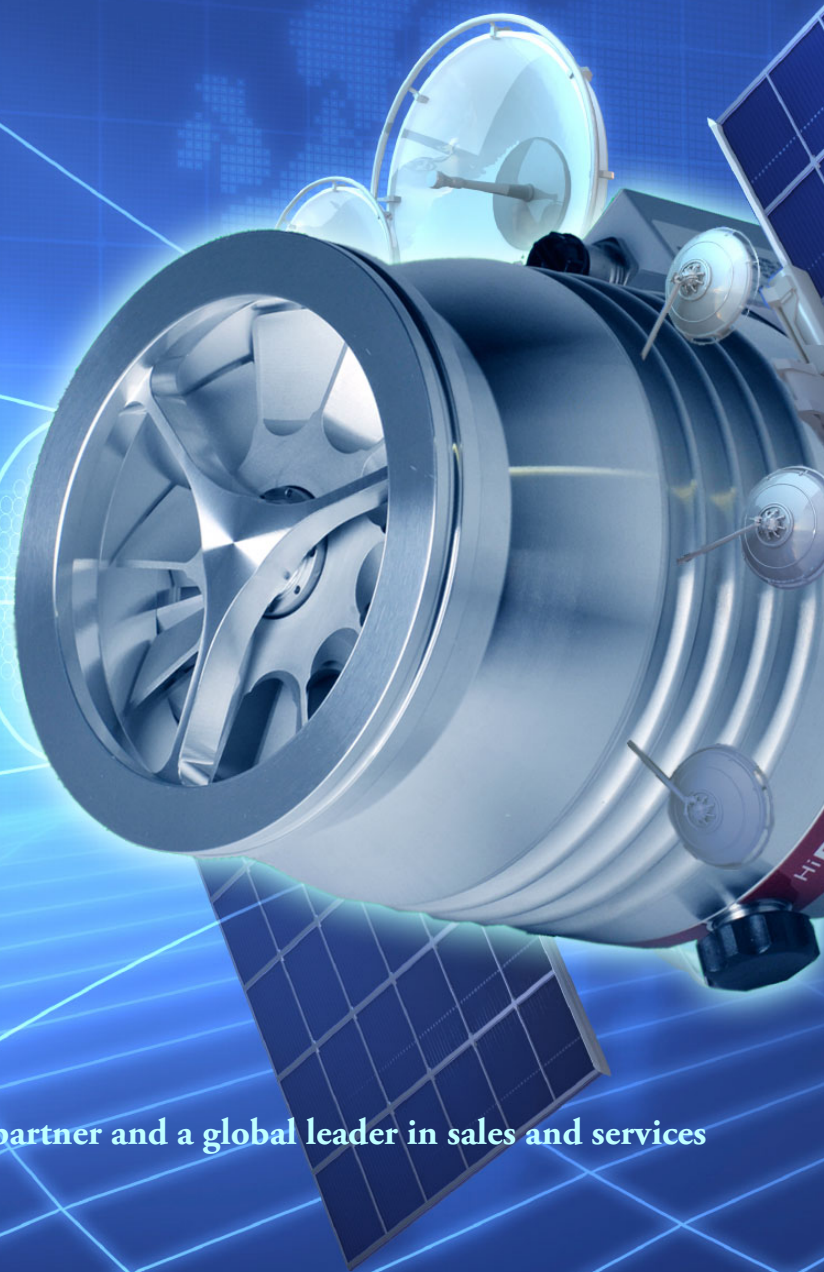

# AJVS

[www.ajvs.com](http://www.ajvs.com)



A&J Vacuum Services is your highly qualified partner and a global leader in sales and services of your High Vacuum equipment.

A&J Vacuum Services, Inc.  
790 Bloomfield Ave., Suite B3  
Clifton, NJ 07012, USA  
Tel: 973-249-0854  
Fax: 973-249-0855  
Website: [www.ajvs.com](http://www.ajvs.com)

Customer Service: [info@ajvs.com](mailto:info@ajvs.com)  
Sales Inquiries: [sales@ajvs.com](mailto:sales@ajvs.com)  
Service Inquiries: [service@ajvs.com](mailto:service@ajvs.com)  
Technical Assistance: [tech@ajvs.com](mailto:tech@ajvs.com)  
Order Status: [tracking@ajvs.com](mailto:tracking@ajvs.com)

# *Instruction Manual*

## EMF3, EMF10 and EMF20 Oil Mist Filters

Description	Item Number
EMF3 Oil Mist Filter	A462-20-000
EMF10 Oil Mist Filter	A462-26-000
EMF20 Oil Mist Filter	A462-29-000



This page has been intentionally left blank.

# Contents

Section	Page
1 Introduction .....	1
1.1 Scope and definitions .....	1
1.2 Description .....	1
1.3 Applications .....	3
1.4 Connections .....	3
2 Technical data .....	5
2.1 Operating and storage conditions .....	5
2.2 Performance .....	5
2.3 Mechanical data .....	5
3 Installation .....	7
3.1 Unpack and inspect .....	7
3.2 Install the EMF filter .....	7
3.2.1 Install the EMF filter on Speedivac 2 pumps .....	7
3.2.2 Install the EMF filter on other pumps .....	8
4 Operation .....	9
5 Maintenance .....	11
5.1 Introduction .....	11
5.2 Change the filter elements .....	11
6 Storage and disposal .....	13
6.1 Storage .....	13
6.2 Disposal .....	13
7 Spares and accessories .....	15
7.1 Introduction .....	15
7.2 Spares .....	15
7.3 Accessories .....	16
7.3.1 Fittings .....	16
7.3.2 Oil drain kits .....	16

For return of equipment, complete the HS Forms at the end of this manual.

# Illustrations

Figure	Page
1 Component parts of the EMF oil mist filters .....	2
2 Dimensions (mm) .....	6
3 Fit the filter to the pump .....	8

# Tables

Table	Page
1 Checklist of items .....	7

# 1 Introduction

## 1.1 Scope and definitions

This manual provides installation, operation and maintenance instructions for the Edwards EMF Oil Mist Filters. You must use the EMF Oil Mist Filter as described in this manual.

Read this manual before you install and operate your EMF series filter. Important safety information is highlighted as WARNING and CAUTION instructions; you must obey these instructions. The use of WARNINGS and CAUTIONS is defined below.



### **WARNING**

Warnings are given where failure to observe the instruction could result in injury or death to people.

### **CAUTION**

Cautions are given where failure to observe the instruction could result in damage to the equipment, associated equipment and process.

The units used throughout this manual conform to the SI international system of units of measurement.

## 1.2 Description

The EMF Oil Mist Filters (shown in [Figure 1](#)) are used to separate and trap oil mist and odours discharged with the exhaust from oil sealed rotary vacuum pumps. All of the EMF Oil Mist Filters are similar in construction.

The Oil Mist Filters have two-part injection moulded plastic bodies which contain a fibre composite oil mist filter and an activated carbon odour filter.

Exhaust gases from the pump travel upwards to the centre of the Oil Mist Filter and through the filter element to the outside. Oil droplets that are trapped by the fibre composite element travel down the filter and collect in a reservoir in the base of the Oil Mist Filter.

Figure 1 - Component parts of the EMF oil mist filters

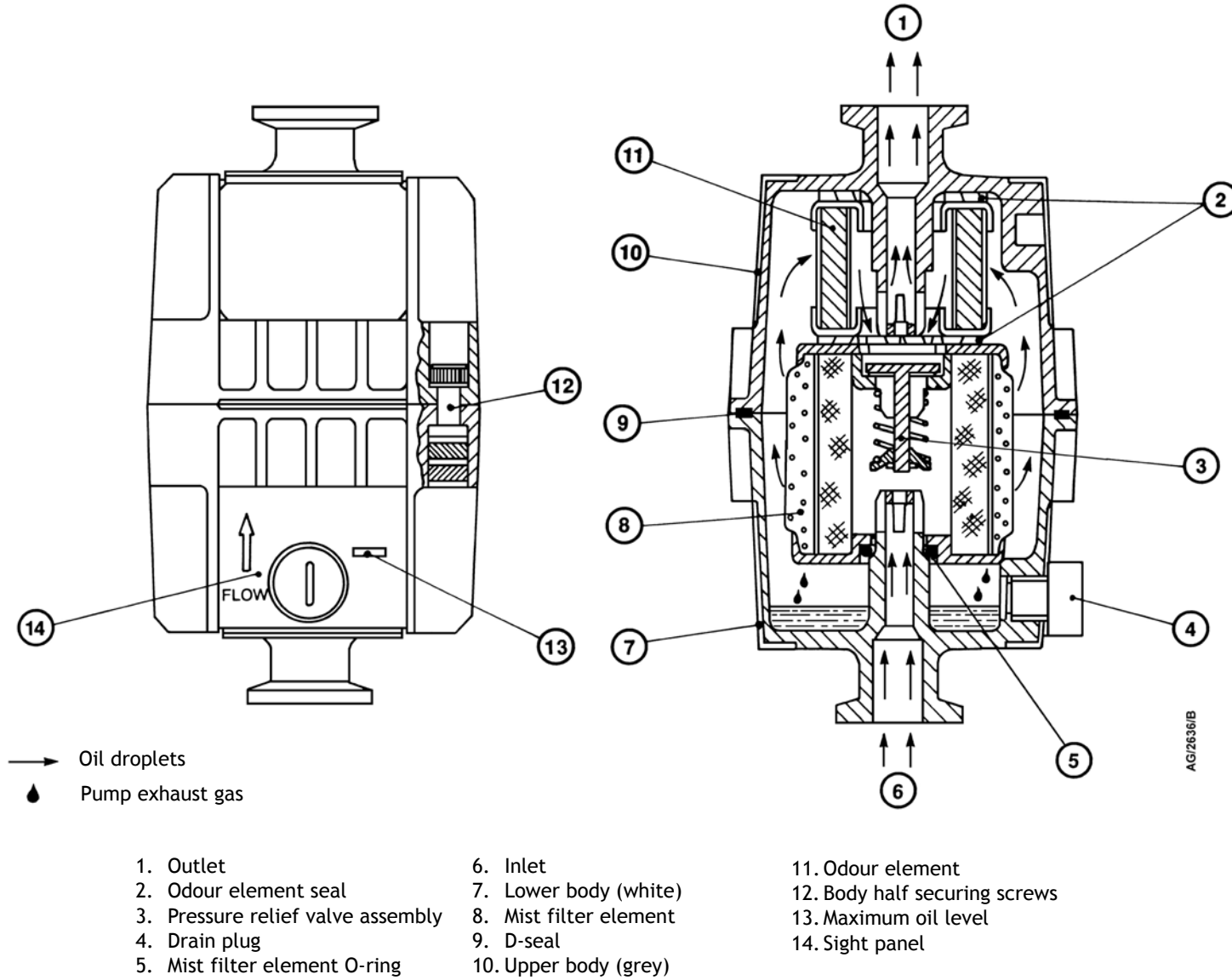

AG/2636/B

The oil-free exhaust fumes then pass through the activated carbon filter element to remove any residual odours.

The filter element has a pressure relief valve. If the element becomes blocked, the pressure relief valve allows exhaust gas to bypass the element and prevents pressure build-up in the pump. The pressure relief valve does not allow gas to escape from the exhaust system. A high exhaust pressure, caused by a blockage elsewhere in the exhaust system, will not be relieved by the pressure relief valve.

The amount of oil that has accumulated in the filter is visible through the sight panel on the lower part of the filter body. When the oil level reaches the maximum oil level ([Figure 1](#), item 13), you should remove the drain plug to drain the oil from the filter.

Accessories are available for the EMF filters for the drainage and return of trapped oil to the pump: refer to [Section 7](#).

### 1.3 Applications

The EMF Oil Mist Filters are resistant to many chemicals and solvents and are unaffected by alkalis, detergents and salt solutions. The EMF Oil Mist Filters are also suitable for use with chemicals that form azide compounds.

If you have any doubt about the suitability of the filter for your application please contact your supplier or Edwards for advice.

### 1.4 Connections

The EMF series filters are manufactured with NW flanges sized to suit the dimensions of the filter and the pump that it is designed to fit.

This page has been intentionally left blank.

## 2 Technical data

### 2.1 Operating and storage conditions

Ambient temperature range (operation)	0 to 45 °C
Ambient temperature range (storage)	-10 to 90 °C

### 2.2 Performance

Rated flow	
EMF3	3 m <sup>3</sup> h <sup>-1</sup>
EMF10	12 m <sup>3</sup> h <sup>-1</sup>
EMF20	20 m <sup>3</sup> h <sup>-1</sup>
Maximum back pressure	12 psig (1.8 bar absolute, 1.8 x 10 <sup>5</sup> Pa)
Relief pressure	20 psig (2.37 bar absolute, 2.37 x 10 <sup>5</sup> Pa)

### 2.3 Mechanical data

Dimensions	See <a href="#">Figure 2</a>
Mass	
EMF3	0.315 kg
EMF10	0.5 kg
EMF20 and EMF20HS	0.7 kg
Odour filter element	Activated carbon
Mist filter element	Epoxy impregnated borosilicate glass fibre
Filter body material	Crystalline nylon
Flange size (inlet and outlet)	
EMF3	NW10
EMF10	NW25
EMF20 and EMF20HS	NW25
For use with Edwards rotary pumps type	
EMF3	Speedivac 2, E2M1.5, E2M2
EMF10	RV3, RV5, RV8, E1M5, E2M5, E1M8, E2M8, E2M12
EMF20	RV12, E1M18, E2M18

Figure 2 - Dimensions (mm)

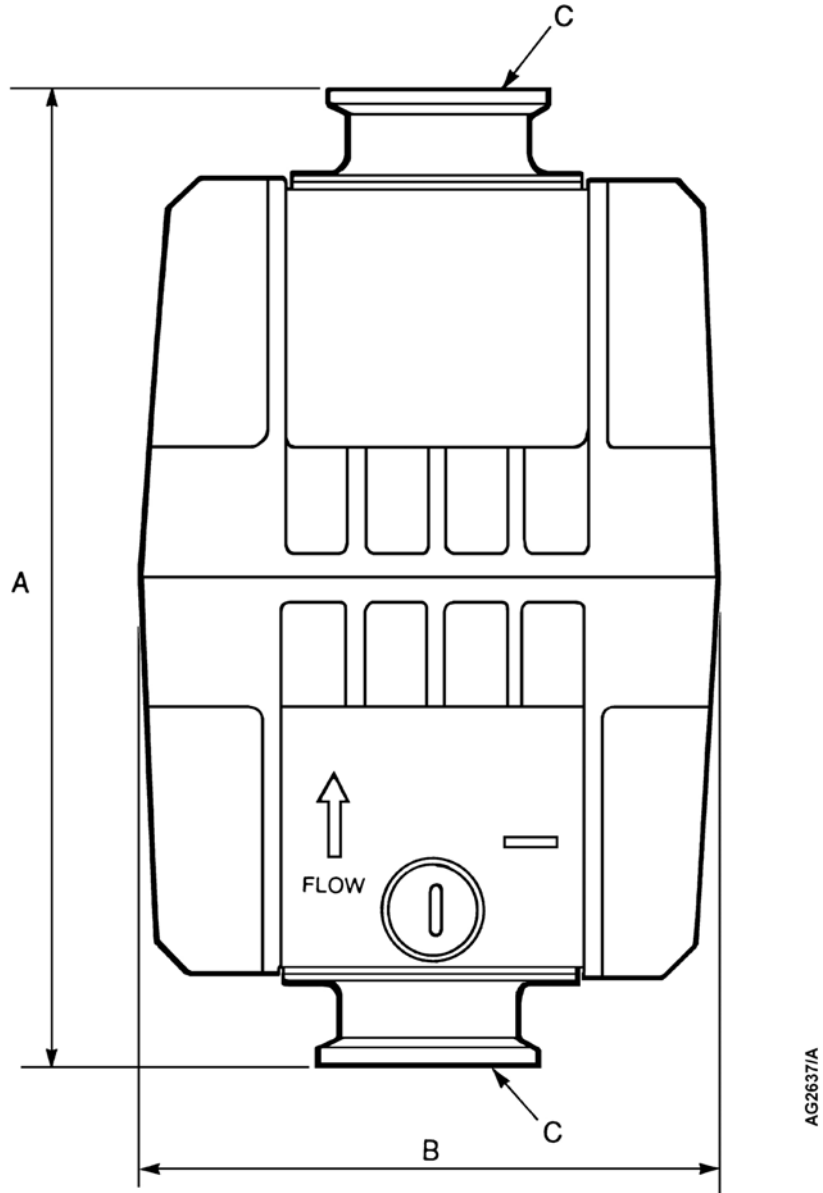

Dimension	Oil Mist Filter		
	EMF3	EMF10	EMF20
A	128	171	191
B	82	97	118.4
C	NW10	NW25	NW25

## 3 Installation

### 3.1 Unpack and inspect

Remove all packing materials and check your EMF Oil Mist Filter. If your filter is damaged, notify your supplier and the carrier in writing within three days; state the Item Number of the filter together with your order number and your suppliers invoice number. Retain all packing materials for inspection. Do not use the filter if it is damaged.

Check that your package contains the items shown in Table 1. If any of these items is missing, notify your supplier in writing within three days.

Table 1 - Checklist of items

Qty	Description	Check (✓)
1	EMF Oil Mist Filter	<input type="checkbox"/>
1	Adaptor	<input type="checkbox"/>
1	Centring-ring and O-ring	<input type="checkbox"/>
1	Clamping ring	<input type="checkbox"/>
1	O-ring seal	<input type="checkbox"/>

If the filter is not to be used immediately, return it to its protective packaging and store in suitable conditions: see Section 6.

### 3.2 Install the EMF filter

#### 3.2.1 Install the EMF filter on Speedivac 2 pumps

**Note:** You can directly fit the EMF3 Oil Mist Filter to current models of the Speedivac 2 pump; however on early models (with Serial Numbers less than 26977), you will need to use two NW10 elbows (with the appropriate seals and clamps) to fit the filter.

You must install the EMF filter vertically with the direction of exhaust flow as indicated by the arrow on the lower part of the body. Use the following procedure to fit the EMF filter:

1. Remove the oil filler plug and the O-ring from the top of the oil box.
2. Remove the outlet nozzle and the Dowty washer from the adaptor, and replace them with the filler plug and O-ring removed from the oil box.
3. Fit the 3/8 inch BSP to NW10 adaptor with Dowty seal (supplied with the EMF filter) into the 3/8 inch threaded hole in the top of the oil box.
4. Use the O-ring and clamping ring supplied to fit the EMF filter to the adaptor.

### 3.2.2 Install the EMF filter on other pumps

You must install the EMF filter vertically with the direction of exhaust flow as indicated by the arrow on the lower part of the body. Use the following procedure and refer to Figure 3:

1. Clean the area around the pump outlet connection.
2. On E1M and E2M pumps only, unscrew and remove the outlet connection from the pump, fit the O-ring seal (5) to the adaptor (4) and screw the adaptor into the pump outlet; do not overtighten the adaptor or you will damage the O-ring seal.
3. Ensure that the sealing surfaces of the filter assembly and pump outlet (or adaptor) are clean, fit the centring-ring (2) to the pump outlet (or adaptor, on E1M and E2M pumps), then position the filter assembly flange on the O-ring. If necessary, rotate the filter so that the oil-level sight panel is visible and so that you can access the drain plug to drain the filter.
4. Fit the clamp (3) and tighten (hand tight only).
5. If required, use a further centring-ring and O-ring and clamp (not supplied) to fit an exhaust pipeline to the outlet of the filter.

Figure 3 - Fit the filter to the pump

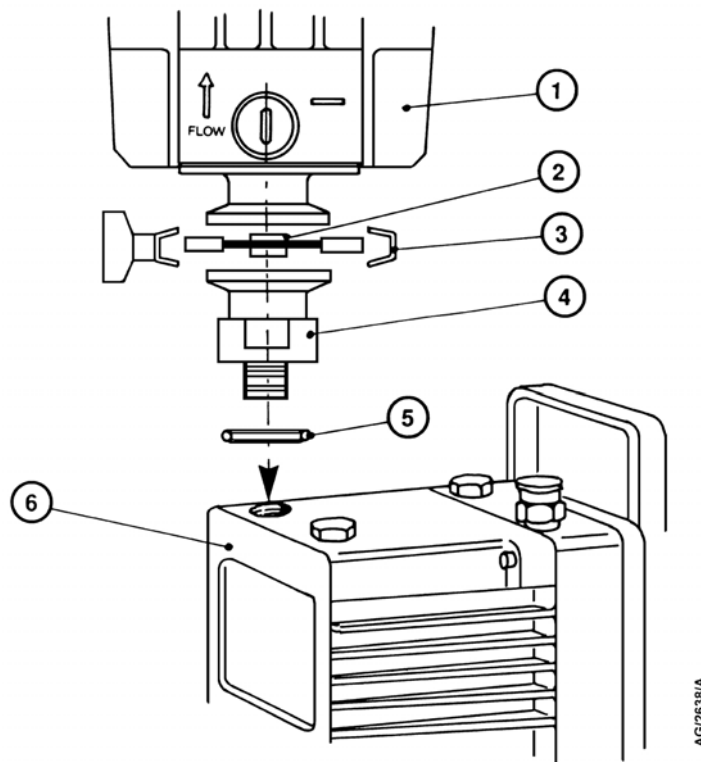

- |                             |            |
|-----------------------------|------------|
| 1. Filter                   | 4. Adaptor |
| 2. Centring-ring and O-ring | 5. O-ring  |
| 3. Clamp                    | 6. Pump    |

## 4 Operation

- Refer to [Figure 1](#). Check the oil level in the filter regularly. Remove the drain plug (4) to drain the oil from the filter when the level reaches the maximum mark (13) on the oil-level sight panel. The rate of oil collection depends on your rotary pump and your process application.
- If you need to drain the filter very frequently, or if you want to reduce the amount of oil you use, fit an oil drain kit accessory: refer to [Section 7](#).

This page has been intentionally left blank.

## 5 Maintenance

### 5.1 Introduction

The life of the mist filter depends on the process application. For most applications, you should change the mist filter element every six months. For applications which contaminate the rotary pump oil, this period will be reduced and must be determined from experience. If the filter element becomes blocked, the pressure relief valve will operate and allow unfiltered exhaust gases to pass through the filter.

Change the odour element monthly or whenever the pump emits an oily odour.

### 5.2 Change the filter elements



#### WARNING

Take all necessary precautions if toxic or dangerous substances have been pumped. Wear protective clothing when you handle contaminated filters and filter elements.



#### WARNING

Ensure that the mist filter element O-ring is in place when you fit new filter elements. If you do not, the pump exhaust gases will not be treated and oil mist will pass out of the mist filter into the local environment and could cause injury to people.

1. Switch off the electrical supply to the pump.
2. Wipe clean the outside of the filter.
3. Refer to [Figure 1](#). Remove the drain plug (4) to drain the oil from the filter. When the filter is fully drained, replace the drain plug.
4. If you have connected an exhaust pipeline to the filter outlet (1), disconnect it.
5. Undo and remove the four screws (12) which secure the upper body (10) to the lower body (7), then remove the upper body.
6. Lift out the filter elements (8, 11) to be changed. Dispose of the used elements safely.
7. Wipe clean the inside of the upper body (10) and lower body (7) and the mating surfaces. Do not remove the D-seal (9).
8. Ensure that the mist filter element O-ring (5) is in place in the lower body (7), then fit the new filter elements; ensure that the foam sealing rings on the top and bottom of the elements are correctly seated.
9. Refit the upper body (10) to the lower body (7) and secure with the screws (12) removed in [Step 5](#).
10. If fitted, reconnect your exhaust system pipeline to the filter outlet (1).

This page has been intentionally left blank.

## 6 Storage and disposal



### WARNING

Take all necessary precautions if toxic or dangerous substances have been pumped. Wear protective clothing when you handle contaminated filters and filter elements.

### 6.1 Storage

1. Remove the contaminated filter elements and use a suitable cleaning solution to clean the filter.
2. Return the EMF Oil Mist Filter to its protective packaging.
3. Store in a cool dry place.
4. When required for use, install the EMF Oil Mist Filter as described in [Section 3](#).

### 6.2 Disposal

Dispose of the EMF Oil Mist Filter, oil trapped in the filter and used filter elements safely in accordance with all local and national safety and environmental requirements.

This page has been intentionally left blank.

## 7 Spares and accessories

### 7.1 Introduction

Edwards products, spares and accessories are available from Edwards companies in Belgium, Brazil, China, France, Germany, Israel, Italy, Japan, Korea, Singapore, United Kingdom, U.S.A, and a world-wide network of distributors. The majority of these centres employ Service Engineers who have undergone comprehensive Edwards training courses.

Order spare parts and accessories from your nearest Edwards company or distributor. When you order, please state for each part required:

- Model and Item Number of your equipment
- Serial number (if any)
- Item Number and description of part

When you maintain this Edwards product, we recommend you use only Edwards maintenance and service kits.

### 7.2 Spares

Description	Item Number
Oil mist filter elements	
EMF3	A223-04-197
EMF10	A223-04-198
EMF20	A223-04-199
Odour elements (pack of 5)	
EMF3	A223-04-081
EMF10	A223-04-079
EMF20	A223-04-077
D-seal (between the upper and lower body halves)	
EMF3	A271-59-536
EMF10	A271-59-535
EMF20	A271-59-534

## 7.3 Accessories

### 7.3.1 Fittings

Description	Item Number
Clamping ring (stainless steel)	
NW10	C105-12-401
NW25	C105-14-401
Centring-ring and O-ring (stainless steel/nitrile)	
NW10	C105-11-396
NW25	C105-14-396
Serrated nozzle to 12 mm o.d. tube (aluminium)	
NW10	C105-11-645
NW25	C105-14-645
NW25 nozzle to 1 inch i.d. tube (stainless steel)	C105-04-225
NW25 nozzle to 15 mm o.d. tube (aluminium)	C105-04-226
3/4 inch nozzle to 15 mm o.d. tube (plastic)	A505-09-000

### 7.3.2 Oil drain kits

Three types of oil drain kit are suitable for use with the EMF Oil Mist Filters:

- EMF Clean Application Oil Drain Kits continuously return the oil trapped in the EMF Oil Mist Filter to the pump. You cannot use a Continuous Oil Drain Kit if you use the pump in processes in which condensable vapours or sodium azides are pumped.
- EMF Gas Ballast Oil Drain Kits continuously return the oil trapped in the EMF Oil Mist Filter to the pump. When fitted, the pump will operate as if the gas ballast control is in position II.
- EMF Gravity Oil Drain Kits return the oil trapped in the EMF Oil Mist Filter to the pump when the pump is at ultimate vacuum or is switched off. Oil is not returned to the pump when gas-ballast is on or when the pump is pumping down to ultimate vacuum. You can continue to use the gas ballast control on the pump when you have fitted an EMF Gravity Oil Drain Kit.

Description	Item Number
EMF Clean Application Oil Drain Kit for RV3 to RV12, Speedivac 2 and E2M0.7 to E2M12 pumps	A504-19-000
EMF Clean Application Oil Drain Kit for E1/E2M18 and E2M28 pumps	A504-20-000
EMF Gravity Oil Drain Kit for RV3 to RV12, E1/E2M2, 5, 8 and 12 pumps	A505-01-000
EMF Gas Ballast Oil Drain Kit for RV3 to RV12 pumps	A505-23-000