

## Okta AM/ADM/G, UniDry 50 M

Motor change at pumps with magnetic coupling

# Operating Instructions

## Validity

This supplementary information describes important variations to the standard product and is only valid together with the prevailing operating instructions.

- Okta AD/ADM-Version and UniDry™ 50 PM/SM/PDM/SDM

This supplementary sheet describes the exchange-service of motor and coupling for pumps with magnetic coupling system.

## Type-dependent special tools

- for **Okta 250/500 AM/ADM, UniDry 050™** PM/PDM/SM/SDM
  - 2 piec. guide pins Ø10.5 x 95 (with M10 x 15)
  - 2 piec. pulling-off screws M10 x 90
- for **Okta 1000 AM/ADM**
  - 2 piec. guide pins Ø12.5 x 125 (with M12 x 15)
  - 2 piec. pulling-off screws M8 x 30
- for **Okta 2000 AM/ADM, Okta 500 G**
  - 2 piec. guide pins Ø12.5 x 140 (with M12 x 15)
  - 4 piec. pulling-off screws M12 x 45 and M12 x 90
- for **Okta 4000/6000 AM/ADM, Okta 1500 G**
  - 2 piec. guide pins Ø12.5 x 160 (with M12 x 15)
  - 4 piec. pulling-off screws M12 x 45 and M12 x 90

## Maintenance / replacement

The following safety instructions are only valid for the **disassembly** of the drive system for vacuum pumps with **magnetic coupling!**



### DANGER

#### Strong magnetic field in the vicinity of the drive system!

Danger to life for persons with cardiac pacemakers when the drive system is disassembled.

- Persons with cardiac pacemakers must not enter the area ( $\leq 2\text{m}$ ) of the magnetic field.
- Rooms in which open couplings are accessible must be identified: "No trespassing for persons with heart pacemaker"!
- Disassembled magnetic couplings must be kept away from computers, data storage media and other electronic components.

### CAUTION

#### Danger of bursting when the motor is removed!

The separating can of the magnetic coupling is made of ceramics, and can be destroyed when the motor is pulled off.

- When removing the motor, suspend it by the eyebolt and pull it off horizontally.
- Use jack screws and guide pins.

## Dismantling/assembling the drive motor at pumps with magnetic coupling

### Dismantling

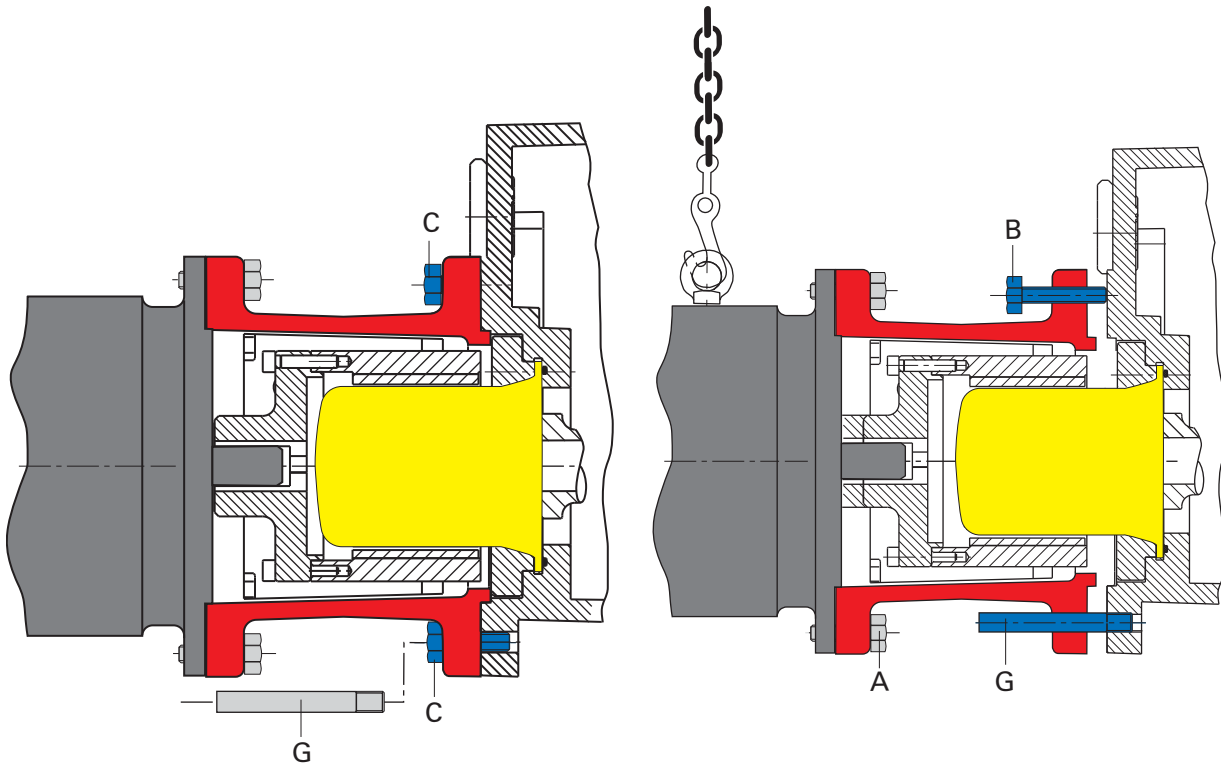

**Fig. 1: Dismantling motor and lantern**

A	Screws	C	Screws
B	Pulling-off screws	G	Guide pins

- Unscrew two diagonally arranged screws C from the lantern at the pump side.
- Screw in two guide pins G in place of the two screws C.
- Hang motor on the eye bolt;
  - depending on the type of the pump, the motor weighs 15 kg in the case of the Okta 250 and up to 140 kg in the case of the Okta 6000.
- Also unscrew the two remaining screws.
- Press lantern and motor off evenly with two jack screws and pull off horizontally.

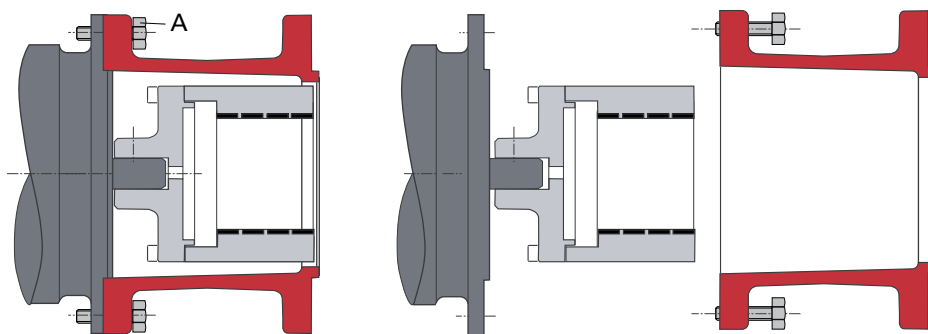

Fig. 2: Dismantling lantern

→ Slackening screws A and remove lantern from motor, use tapped holes if necessary.

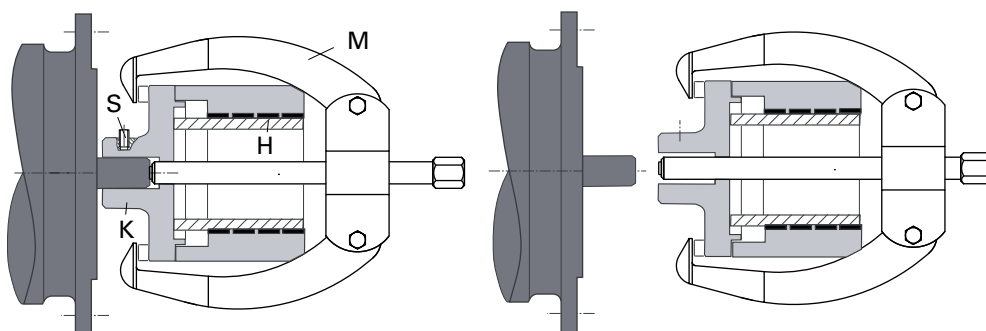

Fig. 3: Extracting the coupling half

H	Protection sleeve	M	Extractor
K	Coupling half	S	Stud screw (10 Nm)

- Loosen stud screw S in coupling half.
- Insert protection sleeve H into the coupling half to protect the magnetic segments.
- Pull off coupling half K with extractor M from the shaft.

### Assembling



#### WARNING

##### **Magnetic force when mounting the magnetic coupling!**

Danger of squeezing and crushing of fingers!

→ Use the pulling-off screws in order to assemble the coupling halves carefully.



#### NOTE

##### **Damage to motor bearings**

Blows or pressure when mounting the coupling half can damage the motor bearings.

- Clean and lightly oil the shaft journals.
- Push the coupling half onto the shaft. If necessary, warm the coupling half, or use the internal thread in the shaft journal and suitable tools and push the coupling half in place.

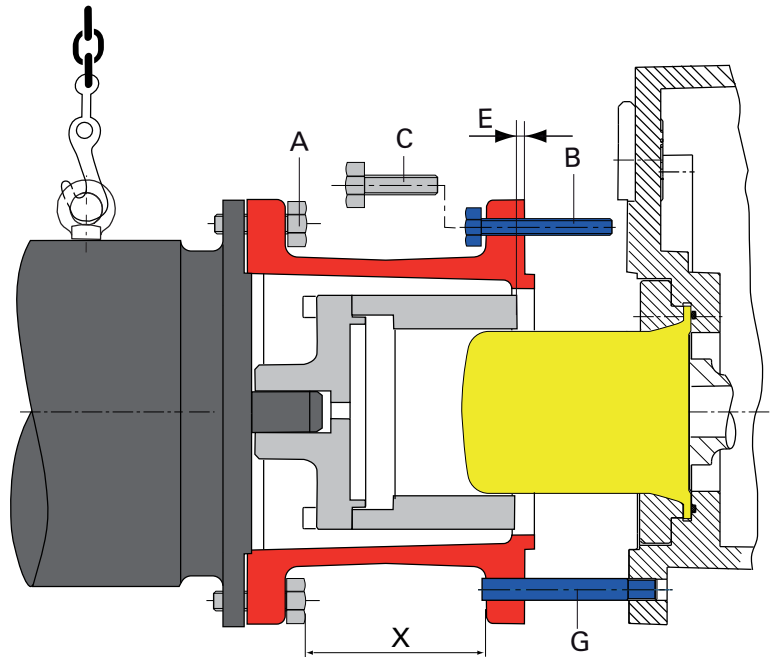

**Fig. 4: Assembling drive motor with pre-assembled lantern**

A	Screws	E	Clearance
B	Pulling-off screws	G	Guide pins
C	Screws		

- Maintain clearance E so that no axial pressure occurs between the coupling half and the separating can.
- Tighten stud bolt S in the coupling half with the prescribed torque and secure with Loctite 222.

Pump type	Clearance E [mm]
Okta 250/500 A/AM	- 0.8
Okta 500 AD/ADM	- 1.5
Okta 1000 A/AM	10.42
Okta 1000 AD/ADM	6.82
Okta 2000 A/AM	16.36
Okta 2000 AD/ADM	13.16
Okta 4000/6000 A/AM	-2
Okta 4000/6000 AD/ADM	-2
Okta 500 G	12.82
Okta 1500 G	-2.3

- Attach the motor with 4 screws A to the lantern.
- Screw in 2 guide pins G of corresponding length into the pump housing;
  - pay attention to dimension X, so that the guide pins can still be screwed out after the motor is installed.
- Hang motor on the eye bolt;
  - depending on the type of the pump, the motor weighs 15 kg in the case of the Okta 250 and up to 140 kg in the case of the Okta 6000.
- Carefully move the motor with lantern to the guide pins and unscrew the pulling-off screws B evenly.
- Screw lantern with 2 screws C onto the pump housing.
- Screw out guide pins G.
- Tighten the two remaining fastening screws C.