



DUO 5 M, DUO 5 MC

Rotary Vane Pump

Operating Instructions

Table of contents

1	About this manual	3
1.1	Validity	3
1.2	Conventions	3
2	Safety	5
2.1	Safety precautions	5
2.2	Protective equipment	5
2.3	Proper use	6
2.4	Improper use.	6
3	Transport and storage	7
3.1	Transport.	7
3.2	Storage	7
4	Product description	8
4.1	Product identification.	8
4.2	Function	9
5	Installation	10
5.1	Setting up the pump	10
5.2	Connecting the vacuum side.	10
5.3	Connecting the exhaust side.	11
5.4	Connecting to the mains power supply	11
5.5	Filling up the operating fluid	15
5.6	Operations monitoring (Option).	16
6	Operation	17
6.1	Before switching on the pump.	17
6.2	Switching on the pump	17
6.3	Pumping condensable vapours.	17
6.4	Switching off the pump	19
7	Maintenance	20
7.1	Precautions.	20
7.2	Changing the operating fluid.	22
7.3	Cleaning or changing the silencer.	24
8	Decommissioning	25
8.1	Shutting down for longer periods	25
8.2	Re-starting	25
8.3	Disposal	25
9	Malfunctions	26
9.1	Rectifying malfunctions.	27
10	Service	28
11	Spare parts	29
11.1	Spare parts packages	29
12	Accessories	31
13	Technical data	32
13.1	Dimensions	33
	Declaration of conformity	35

1 About this manual

1.1 Validity

This operating manual is for customers of Pfeiffer Vacuum. It describes the functioning of the designated product and provides the most important information for safe use of the unit. The description follows applicable EU guidelines. All information provided in this operating manual refer to the current state of the product's development. The documentation remains valid as long as the customer does not make any changes to the product.

Up-to-date operating instructions can also be downloaded from www.pfeiffer-vacuum.com.

Applicable documents

DUO 5 M/MC	Operating instructions
Declaration of Conformity	Part of this document
Operating instructions for accessories (order-specifically)	see section "accessories"

*also available via www.pfeiffer-vacuum.com

1.2 Conventions

Safety instructions

The safety instructions in Pfeiffer Vacuum operating manuals are the result of risk evaluations and hazard analyses and are oriented on international certification standards as specified by UL, CSA, ANSI Z-535, SEMI S1, ISO 3864 and DIN 4844. In this document, the following hazard levels and information are considered:

DANGER
Immediate danger Death or very severe injuries can occur.
WARNING
Possible danger Injuries or severe property damages can occur.
CAUTION
Possible danger Injuries or property damages can occur.
NOTE
Command or note Command to perform an action or information about properties, the disregarding of which may result in damage to the product.

Pictograph definitions



Prohibition of an action or activity in connection with a source of danger, the disregarding of which may result in serious accidents.



Warning of a displayed source of danger in connection with operation of the unit or equipment.



Command to perform an action or task associated with a source of danger, the disregarding of which may result in serious accidents.

Instructions in the text

→ Work instruction: here you have to do something.

Abbreviations used

C version: Corrosive gas version

Symbols used

The following symbols are used consistently throughout in all illustrations:

- ⓪ Vacuum flange
- Ⓛ Exhaust flange
- Ⓜ Gas ballast valve
- Ⓝ Power connection

2 Safety

2.1 Safety precautions



NOTE

Duty to inform

Each person involved in the installation, operation or maintenance of the vacuum pump must read and observe the safety-related parts of these operating instructions.

→ The operator is obligated to make operating personnel aware of dangers originating from the vacuum pump, the pumped medium and the entire system.



NOTE

Installation and operation of accessories

Pfeiffer Vacuum pumps can be equipped with a series of adapted accessories. The installation, operation and maintenance of connected devices are described in detail in the operating instructions of the individual components.

→ For information on order numbers of components, see "Accessories".

→ Use original accessory parts only.

- Do not expose any body parts to the vacuum.
- Observe the safety and accident prevention regulations.
- Check regularly that all safety precautions are being complied with.
- Do not carry out any unauthorised modifications or conversions to the pumps.
- Depending on the operating and ambient conditions, the surface temperature of the pumps may rise above 70 °C. Use suitable finger guards if necessary.
- When returning the pumps to us please note the instructions in the Service section.

The following safety instructions are only valid for the disassembly of the drive system for a vacuum pump with a magnetic coupling:

- When disassembling the drive system from the pump housing, the strong magnetic field may influence the function and operational reliability of electrical and electronic devices.
- Persons with cardiac pacemakers must keep away from the magnetic coupling.
Danger to life!
– **Minimum distance: 2 m!**
- Disassembled magnetic couplings must be kept away from computers, data storage media and other electronic components.
- Keep the disassembled components of the magnetic coupling separate at all times.
Danger of crushing!
- Do not allow any magnetised parts into the vicinity of the magnetic coupling. Danger of injury!

2.2 Protective equipment

Determined situations concerning the handling of vacuum pumps require wearing of personal protective equipment. The owner, respectively the employer are obligated to provide adequate equipment to any operating persons.



DANGER

Danger to health by hazardous substances during maintenance or installation

Depending on the process vacuum pumps, components or operating fluids can be contaminated by toxic, reactive or radioactive substances.

→ Wear adequate protective equipment during maintenance and repairs or in case of reinstallation.



CAUTION
<p>Risk of injury through hot surfaces Vacuum pumps can become hot during operation.</p> <p>→ Allow the pump to cool before maintenance and repairs. → If necessary wear protective gloves according to directive EN 420.</p>



WARNING
<p>Increased noise emission! Increased noise emission can occur within a limited area surrounding the vacuum pump.</p> <p>→ Provide noise protection or → wear hearing protection.</p>

2.3 Proper use



NOTE
<p>CE conformity The manufacturer's declaration of conformity becomes invalid if the operator modifies the original product or installs additional components.</p> <p>→ Following installation into a plant and before commissioning, the operator must check the entire system for compliance with the valid EU directives and reassess it accordingly.</p>

- The vacuum pump may only be used to generate a vacuum.
- Installation, operating and maintenance regulations must be complied with.
- Other accessories, than those described in this manual, must not be used without the agreement of Pfeiffer Vacuum.

2.4 Improper use

Improper use will cause all claims for liability and warranties to be forfeited. Improper use is deemed to be all use for purposes deviating from those mentioned above, especially:

- Pumping of corrosive gases (exception: pumps in C version).
- Pumping of explosive media.
- Operation in potentially explosive areas.
- Pumping of gases containing impurities such as particles, dusts and condensate; note the vapour compatibility levels of the pump.
- Pumping of substances that tend to sublime.
- Use of the vacuum pump to generate pressure.
- Pumping of liquids.
- The use of operating fluids not specified by Pfeiffer Vacuum.
- Connection to pumps or units which are not suitable for this purpose according to their operating instructions.
- Connection to units which have exposed voltage-carrying parts.

3 Transport and storage

3.1 Transport

Transport instructions

- Remove the locking cap from the vacuum and exhaust flange immediately before connecting!
 - Check the protective strainer, paying attention to the o-ring.
- Use only the handle or the crane eye on the top side of the pump to lift the pump.
 - Is the pumps weight > 25 kg lift the pump by a crane.

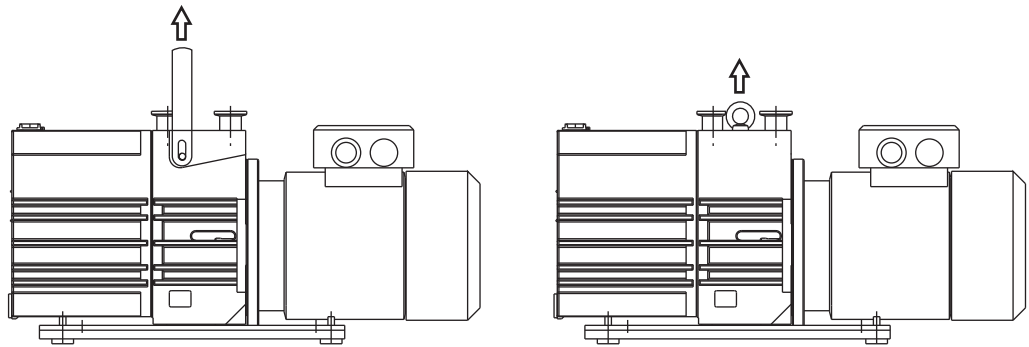

Fig. 1: Transporting the pump

3.2 Storage

- Check that all the openings on the pump are securely closed.
- Store the pump in a cool, dry place; preferably at temperatures between -10 °C and $+40\text{ °C}$.
 - For a longer period of storage, seal the pump in a PE bag with drying agents enclosed.
 - For a period of storage longer than two years, it is recommended to change the operating fluid before using the pump.

4 Product description

4.1 Product identification

To correctly identify the product when communicating with Pfeiffer Vacuum, always have the information from the rating plate available and use it:

- Pump model and model number
- Serial number
- Type and amount of operating fluid
- Date of manufacture

Please find the voltage range and motor-related data on the separately attached motor rating plate.

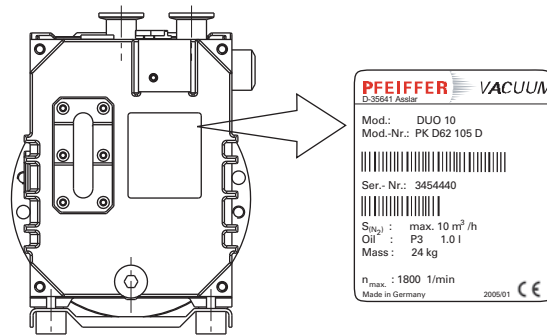

Fig. 2: Product identification on the rating plate

Scope of delivery

- Pump with motor (power cord/power switch --> dependent on the motor type)
- Operating fluid P3 (for standard pump)
- Cone strainer and centering ring with O-ring
- Locking cap for vacuum and exhaust flange
- Operating instructions

Variants

Pump type	Pump versions
DUO 5 M	Standard version of pump
DUO 5 MC	C version of pump; differences from the standard version: <ul style="list-style-type: none"> • Operating fluid F4 • Encapsulated can of the magnetic coupling at the pump system • Vane material changed • Gas ballast valve with dosable flushing gas connection • Leak rate $\leq 1 \cdot 10^{-5}$ mbar * l/s

4.2 Function

The vacuum pumps of the DuoLine® are dual stage rotary vane pumps and are used primarily for rough and medium vacuum applications. The pumps are fitted with a hydraulically controlled vacuum safety valve which, when the pump is at a stillstand, closes the vacuum chamber vacuum tight and at the same time vents the pump. The integrated magnetic coupling functions free of contact and friction. Therefore it is not subjected to any mechanical wear and is completely maintenance free compared to a conventional shaft feedthrough.

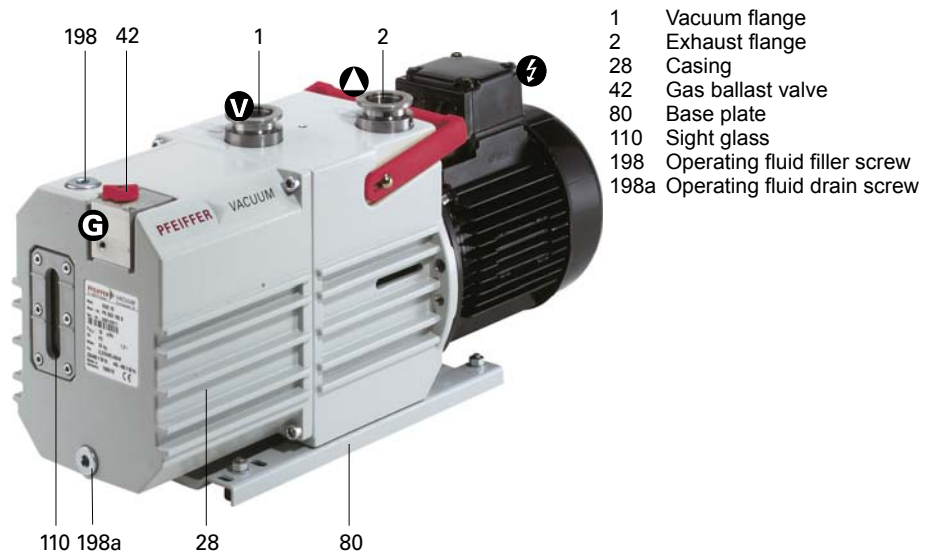

Fig. 3: Rotary Vane Pump DUO 5 M

5 Installation

5.1 Setting up the pump

Installation location

Observe the following requirements when setting up the pump:

- Consider the load-bearing capacity of the installation site.
- Maximum installation altitude 2000 m (above mean sea level)
- Permissible ambient temperature: +12 ... 40°C
- Maximum relative humidity 85%

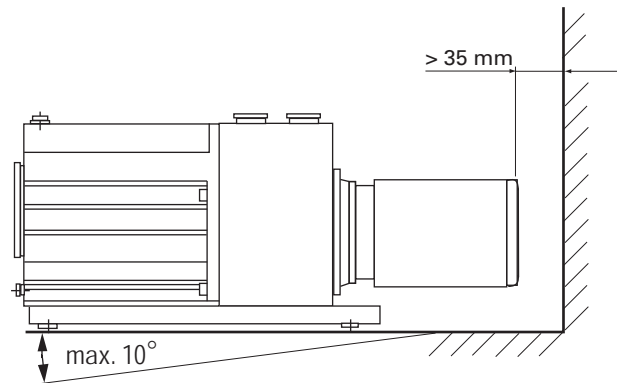

Fig. 4: Setting up the pump

- Fill up with operating fluid before operating the first time (see p. 15, chap. 5.5).
 - Amount and type according to rating plate
- Always place the pump on a firm, even surface.
 - The base frame has four holes for anchoring onto the base.
- When installing the pump in a closed housing, ensure there is sufficient air circulation.
 - Sightglass and gas ballast valve must be visible and readily accessible.
 - Voltage and frequency information given on the motor rating plate must be visible.

5.2 Connecting the vacuum side

- Remove locking cap from the vacuum flange;
 - pay attention to the cone strainer and the respective O-ring in the intake port.
- The connection between the pump and the recipient should be kept as short as possible.
 - Depending on the pump type, use metallic hoses or PVC hoses with flange connections.
 - Separators, filters etc. may be installed upstream to protect the pump (see accessories). However, please observe the loss of pumping capacity due to the conductivity of the accessories.

5.3 Connecting the exhaust side



CAUTION

High pressure in the exhaust line!

Danger of damage to the seals and danger of the pump bursting.

- Install the line without shut-off valves on the exhaust side.
- If there is danger of a build-up of excess pressure (> 1500 mbar abs.) in the lines, observe all official accident prevention safety regulations.
- If the exhaust gases are being extracted, the exhaust pressure must be at least
- 250 mbar greater than the pressure at the intake side.

- Choose the cross-section of the exhaust line to be at least the size of the nominal connection diameter of the vacuum pump's exhaust connection.
- Piping to the pump must be suspended or supported.
 - Physical forces from the piping system must not be allowed to act on vacuum pumps.
- Lay piping from the pump sloping downward so that no condensate can flow back into the pump; otherwise fit a condensate separator.
 - If an air trap is created in the system, then a device for draining condensation water must be provided at the lowest point.



WARNING

Emission of toxic substances from the exhaust!

Danger of poisoning from emitted gases or vapours, which can be detrimental to health and/or can pollute the environment, depending on the particular application.

- Comply with the applicable regulations when working with toxic substances.
- Only officially approved filter systems may be used to separate and remove these substances.

5.4 Connecting to the mains power supply

Depending on the pump type, different motor versions or mains voltages are possible:

- Single phase motor for fixed voltage with a built-in thermal protection switch, mains switch and connecting cable.
- Three phase motor (without switch and mains cable).



DANGER

Voltage-bearing elements

Danger to life from electric shock.

- The electrical connection can be carried out only by trained and authorised electricians.
- Disconnect the power supply and secure it against being switched back on.
- Ensure the system is adequately earthed.



CAUTION

Excess voltage!

Danger of destroying the motor.

- Power connections must comply with local regulations. Voltage and frequency information given on the motor rating plate must correspond to the mains voltage and frequency values.
- To protect the motor and supply cable in case of malfunction, mains fuse protection must be implemented.



WARNING

Danger of injury from moving parts!

After power failure or motor shutdown due to overheating, the motor may restart automatically.

- Secure the motor so that it cannot be switched on while any work is being performed on the pump.
- If necessary, dismantle the pump from the installation for inspection.



NOTE

The transmission power of the pump's magnetic coupling is so great that there is no overload protection for the motor.

Single phase motors

The vacuum pumps are fitted with a built-in thermal protection switch. Depending on the type of pump, different motor versions with a power cord are possible:

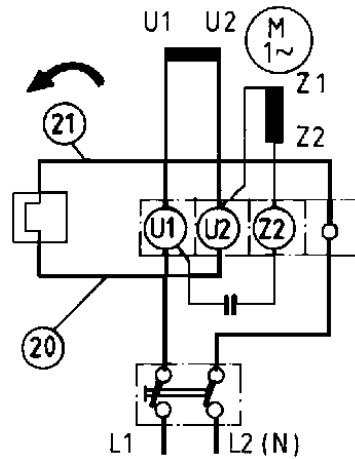

Fig. 5: Motor circuit diagram with switch

Fuse protection

- To protect the motor in case of malfunction, carry out fuse protection in accordance with the regional regulations.
 - Select a fuse with slow characteristics.

Three-phase motor

The Three Phase Current Motor Circuit

The connections U1 - L2, V1 - L1 and W1 - L3 result in a clockwise rotation of the motor shaft as seen looking towards the motor fan.

Delta Connection

The three coils are connected in series with the connection point connected to the mains. The voltage of each coil is the same as the mains voltage whereas the mains current is the cube root of the coil current. Delta connections are denoted by the symbol Δ . The voltage between the mains supply lines is called mains voltage. The mains current is the current which flows in the supply lines.

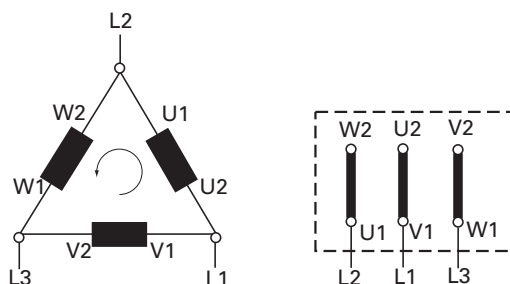

Fig. 6: Motor coil and connecting plate of Delta Connection (for low voltage)

Star Connection

The ends of the three coils are connected at the star center. The terminal voltage is the cube root of the coil voltage; the mains and the coil current are the same. Star connections are denoted by the symbol Y .

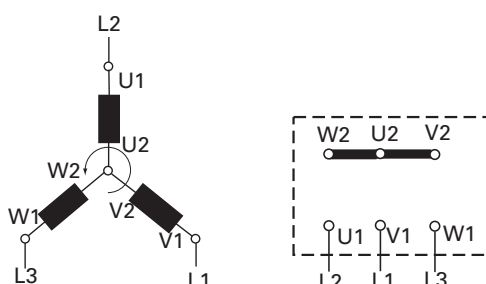

Fig. 7: Motor coil and connecting plate of Star Connection (for high voltage)

Inspection of the direction of rotation

For pumps with three-phase motors, it is necessary to check the direction of rotation!



CAUTION

Operating fluids may leak out!

If the direction of rotation is incorrect, there is a danger that operating fluids may leak at the vacuum flange.

→ Always check the direction of rotation before filling in operating fluid.

- Remove the locking cap from the exhaust flange (if existing).
- Switch the pump on briefly (from 2 to 3 sec.).
 - The motor and motor fan must turn in a clockwise direction (see the arrow on the support stand).
- If the direction of rotation is incorrect: Swap two phase contacts at the connecting cable.
- Fill up the operating fluid.

Motor protection

Pump motors equipped with PTC temperature sensors (3PTC) in the stator windings can be connected to a PTC resistor tripping device for protection against overload. Other approved motor temperature monitoring can be used also by the operator.

Tripping devices store the shutdown event and need to be manually switched back on again via the integrated RESET button or via the external RESET S3. Mains-ON is detected as an automatic RESET.

- Set up the connections so that the directional rotation indicated on the pump is maintained, regardless of the representations in the current flow diagram.

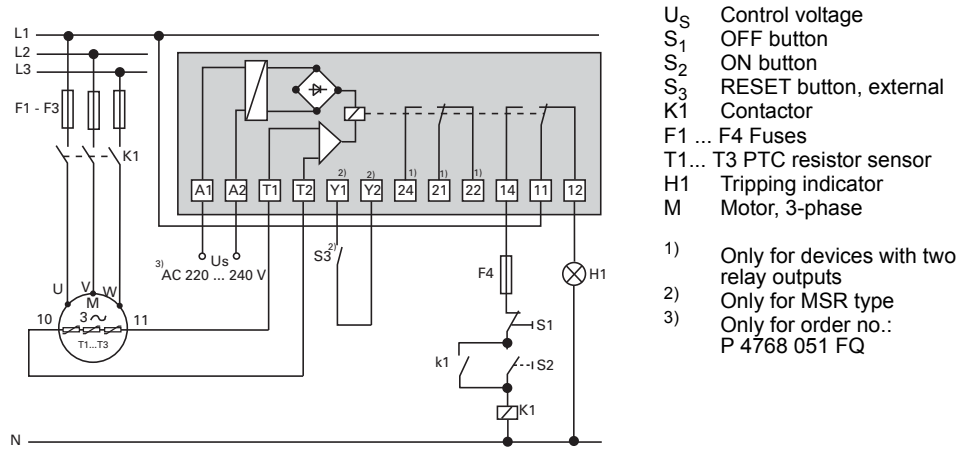

Fig. 8: Connection example for a three-phase AC motor with PTC resistor tripping device



NOTE

Do not start with star/delta connection.

→ Always start motor directly.

5.5 Filling up the operating fluid

The type and amount of operating fluid should be visible on the pump's rating plate for every rotary vane pump.

The delivery consignment for the **standard pump** contains sufficient operating fluid for one filling. Pumps for special applications (e.g. for pumping corrosive gases) can be operated with other operating fluids. These must be defined in accordance with Pfeiffer Vacuum specifications before initial assembly and ordered separately.

Permissible operating fluids

- P3 (Standard operating fluid)
- F4 (Operating fluid for corrosive gas versions)
- D1 (for special applications and higher operating temperature)
 - Final pressure of measurement, depending on the type of gas: $< 5 \cdot 10^{-2}$ mbar



NOTE

Use approved operating fluids only!

The use of operating fluids that have not been approved by Pfeiffer Vacuum shall result in a limited warranty. In such cases, it is not possible to guarantee that product-specific performance data will be achieved.

→ Prior consultation is required before using other application-specific operating fluids.

Filling up the operating fluid

- Unscrew operating fluid filler screw 198.
- Fill up operating fluid.
 - Correct filling level during operations: within the markings at the sightglass frame.

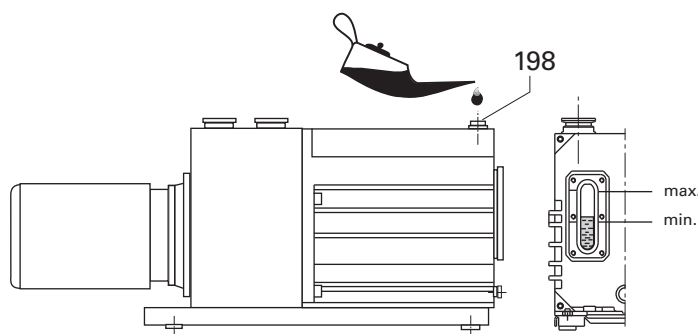

Fig. 9: Filling up the operating fluid

- Screw in operating fluid filler screw 198.
- Check operating fluid level only when the pump is warm and running; close
 - vacuum flange and gas ballast valve to do so,
 - Check operating fluid daily in non-stop operation, otherwise whenever the pump is switched on. Refilling is possible when the pump is in final vacuum operation.



WARNING

Toxic vapours!

Danger of poisoning when igniting and heating synthetic operating fluids (e.g. F4/F5) above 300°C.

- Observe the application instructions.
- Do not allow operating fluid to make contact with tobacco products; observe safety precautions when handling chemicals.

5.6 Operations monitoring (Option)

A pressure switch can be installed on the side of the support to monitor the operating fluid pressure of the rotary vane pump during operations. By pressure drop and when the pump is at rest, the contact of the pressure switch opens. The signal can be used to control external valves.

Switching voltage:	5 ... 250 Volt (potential-free)
Current, max.	2 Amp.
Protection class	IP 55

1 + 2 closers = pressureless open

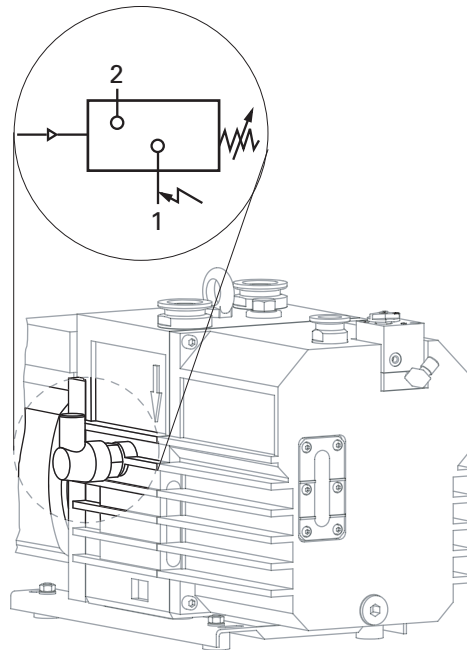

Fig. 10: Installation location and circuit diagram of pressure switch

- Switch off the pump.
- Unscrew and remove locking screw 142 on the support.
- Remove protective cover of the pressure switch and screw in with O-ring.
- Make electrical connections at the pressure switch.
- Reassemble the protective cover.

6 Operation

6.1 Before switching on the pump

- Check the operating fluid level in the sightglass.
- Compare the voltage and frequency information on the rating plate with the mains voltage and frequency values.
- Check that the exhaust connection allows free flow (max. permissible pressure 1.5 bar absolute).
 - Activate the shut-off valves in such a way that they open before or at the same time as the pump is started.
- Protect the pump sufficiently from taking in contaminants by means of suitable precautions (e.g. dust filters); if necessary, check operating fluid regularly or replace at shorter intervals.

6.2 Switching on the pump

The pump can be switched on in any pressure range between atmospheric and ultimate pressure.

No special precautions are necessary when pumping dry gases. In order to attain the lowest possible ultimate pressures, the gas ballast valve should be closed.

- Switch on pump at main switch 15.
- Switch on the pump with the vacuum flange closed and allow to warm up for 30 minutes.



CAUTION

Hot surface!

Danger of burns if hot parts are touched. Depending on the operating and ambient conditions, the surface temperature of the pump may rise above 70 °C.

- In this case, use suitable finger guards.

6.3 Pumping condensable vapours

Should the process gases contain condensable gases present at high percentages, the rotary vane pump must be operated with gas ballast (i.e. with an open gas ballast valve).



CAUTION

Bad final vacuum and damage to the pump!

Danger of condensation and corrosion due to exceeding the water vapour compatibility during operation without gas ballast or in case of insufficient supply of flushing gas.

- Only pump vapours when the pump is warm and the gas ballast valve is open.
- When the process has been completed, allow the pump to continue running for about 30 minutes with the vacuum flange closed and the gas ballast open for operating fluid regeneration purposes.

Gas ballast valve, standard version

To avoid condensation in the pump when pumping condensable vapours, air is periodically fed into the working chamber at the beginning of the compression phase via the gas ballast valve 42.

The gas ballast valve is closed when turning to the right to position 0 and open when turning to the left to position 1. Intermediate settings are not possible.

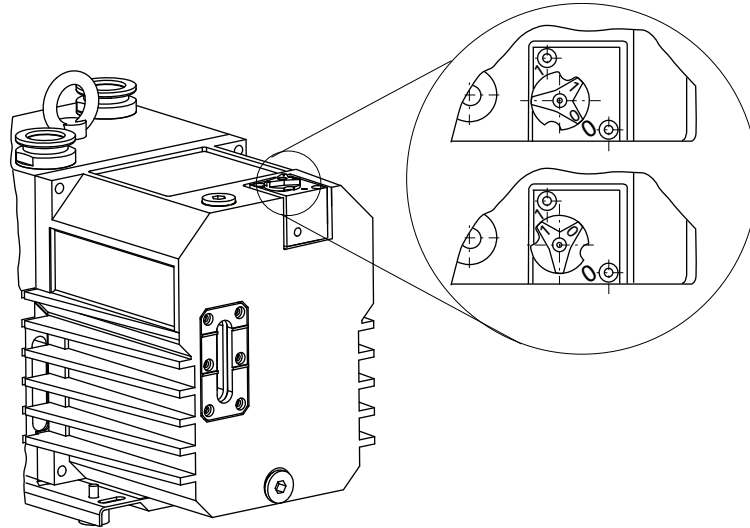

Fig. 11: Standard version 42 of gas ballast valve

Gas ballast valve with flushing gas connection (option)

If the pumping process requires the use of flushing gas, a supply hose can be connected at the gas ballast valve.

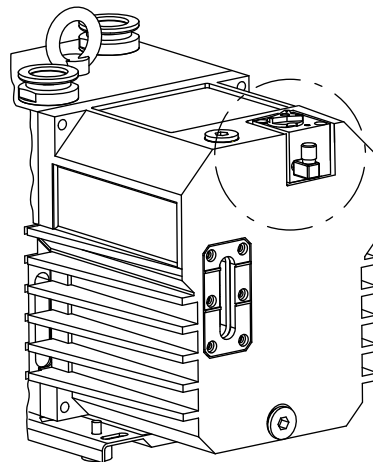

Fig. 12: Gas ballast valve with flushing gas connection



CAUTION

Flushing gas pressure higher than allowed endangers the operational reliability of the pump.

The power input of the pump, the temperature and the ejection of operating fluid will increase.

- Observe the maximum permissible flushing gas pressure.
- Set the amount of flushing gas on site.
- Connect flushing gas at the flushing gas connection.
- Set flushing gas pressure; maximum pressure 1.5 bar (absolute).
 - Select the type and amount of flushing gas depending on the process; consult Pfeiffer Vacuum if necessary.

6.4 Switching off the pump

The pump can be switched off in any pressure range.

Rotary vane pumps have an integrated safety valve on the intake side. If the differential pressure between the exhaust side and the intake side is ≥ 250 mbar, then the valve closes automatically and vents the pump when the pump is switched off.

→ Switch the pump off at the mains switch or disconnect from the mains in a secure manner.

Venting the vacuum chamber



CAUTION

Danger of backflow of operating fluid into the intake line!

Contamination of the connected vacuum system!

- Vent the vacuum chamber within 30 s, regardless of the chamber size.
- For a longer venting process, use an additional shut-off valve and shut off the intake line after switching off the pump.

Maintaining the vacuum in the chamber



CAUTION

Danger of backflow of operating fluid into the intake line!

Contamination of the connected vacuum system!

- Because the safety valve of the pump is not suitable for longer-term sealing, install an additional shut-off valve in the intake line.
- Shut off the intake line immediately after switching off the pump.

7 Maintenance

7.1 Precautions



DANGER

Strong magnetic field in the vicinity of the drive system!

Danger to life for persons with cardiac pacemakers when the drive system is disassembled.

- Persons with cardiac pacemakers must not enter the area ($\leq 2\text{m}$) of the magnetic field.
- Rooms in which open couplings are accessible must be identified: "No trespassing for persons with heart pacemaker"!
- Disassembled magnetic couplings must be kept away from computers, data storage media and other electronic components.

WARNING

Danger of injury from moving parts!

After power failure or motor shutdown due to overheating, the motor may restart automatically.

- Secure the motor so that it cannot be switched on while any work is being performed on the pump.
- If necessary, dismantle the pump from the installation for inspection.

WARNING

Pump parts may be contaminated from pumped media!

Danger of poisoning due to contact with harmful substances.

- Decontaminate the pump before carrying out any maintenance work.
- In the event of contamination, take suitable safety precautions to prevent your health from being harmed by any dangerous substances.
- Turn off the vacuum pump, vent to atmospheric pressure and allow to cool, if necessary.
- Disconnect the drive motor from the mains and secure it so that it cannot be switched on.
- Only dismantle the pump as far as necessary in order to repair defects.
- Dispose of used operating fluid in compliance with local regulations.
- When using synthetic operating fluids or working with toxic substances or substances contaminated with corrosive gases, the relevant instructions governing their use must be observed.
- Use only alcohol or similar agents for cleaning pump parts.

Checklist for inspection, maintenance and overhaul

Certain repair and overhaul work should only be performed by Pfeiffer Vacuum Service (PV). Pfeiffer Vacuum will be released from all warranty and liability claims if the required intervals for inspection, maintenance, or overhaul are exceeded or inspection, maintenance, repair or overhaul procedures are not performed properly. This also applies if replacement parts other than Pfeiffer Vacuum OEM replacement parts are used.

Activity	daily	as required; at least annually	as required; at least every 2 years	as required; at least every 4 years
Check operating fluid level	X			
Visual inspection (leak-tightness/oil leaks)	X			
Check filter insert of external oil mist filter (if existent)	X			
Change filter insert of external oil mist filter (if existent)		X		
Change operating fluid		X		
Cleaning the pump and renew the seals		X		
Clean gas ballast valve and silencer nozzle		X		
Clean the motor fan cap		X		
Clean or change vacuum safety valve			X (PV)	
Clean or change exhaust valves			X (PV)	
Change vanes and hydraulic vane				X (PV)
Check or change coupling				X (PV)

Depending on the process, the required replacement intervals for lubricants and the intervals for inspection, maintenance and overhaul may be shorter than the guide values specified in the table. Consult with Pfeiffer Vacuum Service if necessary.

7.2 Changing the operating fluid

The changing interval for the operating fluid depends on the pump applications, but should be carried out once a year.



NOTE

Depending on the applications, Pfeiffer Vacuum recommends determining the exact service life of the operating fluid during the first year of operation.

The replacement interval may vary from the guide value specified by Pfeiffer Vacuum depending on the thermal and chemical loads, and the accumulation of suspended particles and condensation in the operating fluid.



WARNING

Hot operating fluid!

Danger of burns when draining due to contact with skin.

- Wear suitable protective clothing.
- Use a suitable collecting vessel.

- The level of deterioration of operating fluid P3 can be determined for clean processes with the colour scale (in accordance with DIN 51578); supplementary sheet PK 0219 BN on request or download it from the Internet.
- Suck off operating fluid from the pump through the operating fluid filler opening.
- Fill the specimen in a test tube or some similar vessel and test by holding against the light.
- Where discolouration is red brown (equivalent to 5 on the scale) change operating fluid.
- Switch off the pump.
- Unscrew operating fluid filler screw 198.
- Unscrew operating fluid drain screw 198a.

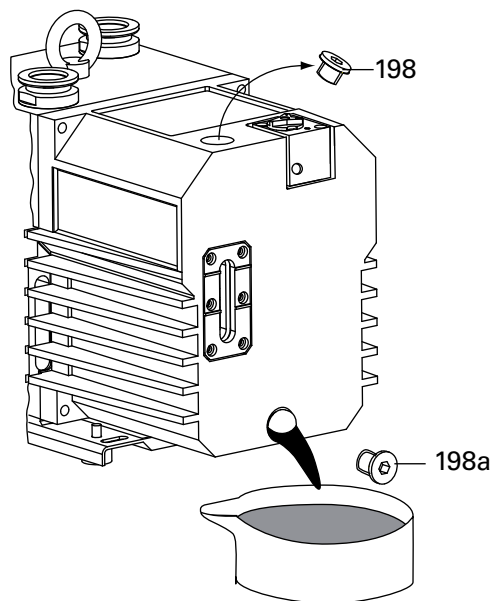

Fig. 13: Draining the operating fluid



WARNING

Operating fluid may contain toxic substances from the pumped media!

Danger of poisoning from the emission of harmful substances from the operating fluid.

- Wear suitable protective clothing and respirators.
- Dispose of operating fluid according to the local regulations

- Screw in operating fluid drain screw 198a; pay attention to O-ring.
- Screw in operating fluid filler screw 198.
- Allow pump to run for a maximum of 5 seconds with the vacuum flange open.
- Drain off remaining operating fluid.
 - In case of serious contamination, the operating fluid will have to be changed several times (flushing):

Flushing

- Fill up with operating fluid to the middle of the sight glass.
- Operate the pump with the gas ballast open until the pump has warmed up.
- Drain the operating fluid again and check for contamination, flush again if necessary.
- Screw the operating fluid drain screw back in.
- Fill up with operating fluid and check the filling level (*see p. 15, chap. 5.5*).



NOTE

Request safety data sheets for operating fluids and lubricants

from Pfeiffer Vacuum or download them from the Internet.

- Dispose of operating fluid according to the local regulations.

7.3 Cleaning or changing the silencer

The silencer 44 is a nozzle inside the pump housing and cannot be altered; when dirty it should either be cleaned or replaced.

Dismantling

- Unscrew 2 cheesehead screws 182 from the gas ballast valve housing.
- Remove the gas ballast valve housing 42 from the casing 28; taking care with o-ring 148.
- Unscrew silencer nozzle 44 and o-ring 138; clean it and replace o-ring 138 if necessary.

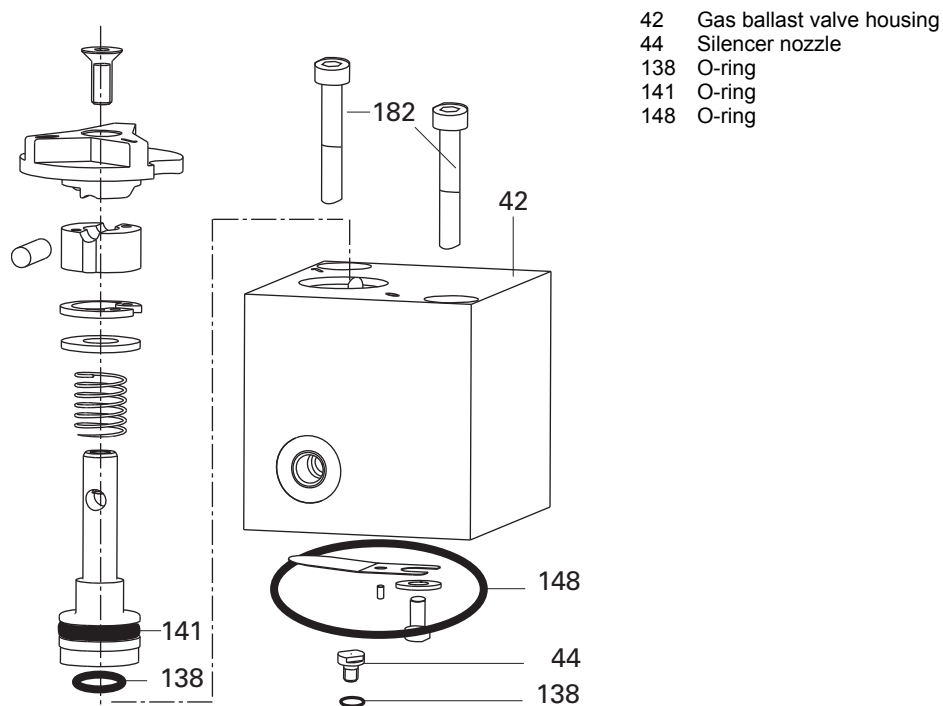

Fig. 14: Gas ballast valve with silencer nozzle 44

8 Decommissioning

8.1 Shutting down for longer periods

Before shutting down the pump, observe the following procedure and adequately protect the pump system against corrosion:

- Switch off pump.
- Change operating fluid
- Start the pump and allow the pump to warm up.
- Switch off the pump.
- Fill up the pump with new operating fluid to the top edge of the sightglass.
- Close vacuum flange and exhaust flange with locking caps.
- Store the pump in a cool, dry place; preferably at temperatures between -10 °C and +40 °C.
 - For a longer period of storage, seal the pump in a PE bag with drying agents enclosed.
 - For a period of storage longer than two years, it is recommended to change the operating fluid before using the pump.
- Do not store pump in the vicinity of machines, lanes, etc., because strong vibrations can damage the rotor bearings.

8.2 Re-starting



CAUTION

Emission of operating fluid!

Danger of the operating fluid being emitted at the exhaust flange if overfilled.

- Drain the operating fluid to the normal level before restarting the pump.



CAUTION

Re-starting

The serviceability of the operating fluid without operation is a maximum of 2 years. Before restarting after a shut-down of **2 years or longer**, carry out the following work.

- Replace the operating fluid.
- Replace the elastomer parts, with reference to DIN 7716 and the manufacturer's specifications.
- Follow the maintenance instructions and inform Pfeiffer Vacuum.

8.3 Disposal

Products or parts thereof (mechanical and electrical components, operating fluids, etc.) may cause environmental burden.

- Safely dispose of the materials according to the locally applicable regulations.

9 Malfunctions

Please note the following instructions should the pump malfunction:



CAUTION

Hot surface!

Danger of burns if hot parts are touched. The surface temperature of the pump may rise above 105 °C in case of malfunction.

→ Carry out work on the pump only after it has cooled to a safe temperature.



NOTE

Motor overload!

Depending on the malfunction (e.g. blocking during cold start), the motor may not be sufficiently protected by the built-in thermal protection switch from damage through overheating.

→ Implement an additional network safety device.

9.1 Rectifying malfunctions

Problem	Mögliche Ursachen	Behebung
Pump will not start up	No mains voltage or voltage does not correspond to the motor data	Check mains voltage and mains fuse protection; check motor switch
	Pump temperature too low	Warm up pump to > 12°C
	Thermal protection switch has responded	Detect and fix cause of overheating; allow pump to cool off if necessary
	Pump system dirty	Clean pump; contact Pfeiffer Vacuum Service if necessary
	Pump system damaged	Clean and overhaul pump; contact Pfeiffer Vacuum Service if necessary
	Motor defective	Replace motor
Pump switches off after a while after being started	Thermal protection switch of the motor has responded	Detect and fix cause of overheating; allow motor to cool off if necessary
	Mains fuse protection triggered due to overload (e.g. cold start)	Warm up pump
	Exhaust pressure too high	Check opening of exhaust line and exhaust accessories
Pump does not attain final pressure	Measurement reading is false	Check gauge, check final pressure without installation connected
	Pump or connected accessories are dirty	Clean pump and check components for contamination
	Operating fluid dirty	Operate pump for a longer period with gas ballast valve open or change operating fluid
	Leak in system	Repair leak
	Operating fluid filling level too low	Top off operating fluid
	Pump damaged	Contact Pfeiffer Vacuum Service
Pumping speed of pump too low	Intake line not well-dimensioned	Keep connections as short as possible and see that cross-sections are sufficiently dimensioned
	Exhaust pressure too high	Check opening of exhaust line and exhaust accessories
Loss of operating fluid	Swivel gasket leaky	Check tightness; replace gasket if necessary
	Operational loss of operating fluid	If necessary, install oil mist filter and oil return unit
Unusual operating noises	Silencer dirty	Clean or replace the silencer; (see p. 24, chap. 7.3)
	Damage to the pump system	Clean and overhaul pump; contact Pfeiffer Vacuum Service if necessary
	Motor bearing defective	Replace motor; contact Pfeiffer Vacuum Service if necessary



NOTE

Service work should be carried out by qualified personal only!

Pfeiffer Vacuum is not liable for any damage to the pump resulting from work carried out improperly.

→ Take advantage of our service training programs; additional information at www.pfeiffer-vacuum.com.

→ Please state all the information on the pump rating plate when ordering spare parts.

10 Service

Pfeiffer Vacuum offers first-class service!

- Maintenance/repairs on site by Pfeiffer Vacuum field service
- Maintenance/repairs in a nearby service center or service point
- Fast replacement with exchange products in mint condition
- Advice on the most cost-efficient and quickest solution

Detailed information and addresses at: www.pfeiffer-vacuum.com (Service).

Maintenance and repairs in Pfeiffer Vacuum ServiceCenter

The following steps are necessary to ensure a fast, smooth servicing process:

- Download the forms "Service Request" and "Declaration on Contamination".¹⁾
- Fill out the "Service Request" form and send it by fax or e-mail to your Pfeiffer Vacuum service address.
- Include the confirmation on the service request from Pfeiffer Vacuum with your shipment.
- Fill in the contamination declaration and enclose it in the shipment (required!).
- Dismantle all accessories.
- Drain operating fluid/lubricant.
- Drain cooling medium, if used.
- Send the pump or unit in its original packaging if possible.

Sending of contaminated pumps or devices

No units will be accepted if they are contaminated with micro-biological, explosive or radioactive substances. "Hazardous substances" are substances and compounds in accordance with the hazardous goods directive (current version). If pumps are contaminated or the declaration on contamination is missing, Pfeiffer Vacuum performs decontamination at the shipper's expense.

- Neutralise the pump by flushing it with nitrogen or dry air.
- Close all openings airtight.
- Seal the pump or unit in suitable protective film.
- Return the pump/unit only in a suitable and sturdy transport container and send it in while following applicable transport conditions.

Service orders

All service orders are carried out exclusively according to our repair conditions for vacuum units and components.

¹⁾ Forms under www.pfeiffer-vacuum.com

11 Spare parts

11.1 Spare parts packages

The spare parts packages listed here are only applicable for standard models.

Please state all information on the rating plate when ordering spare parts. Other spare parts than those described in this manual must not be used without the agreement of Pfeiffer Vacuum.

Spare parts package	Pump type	Article no.	Parts according to the exploded view on the following page
Set of seals	DUO 5 M DUO 5 MC	PK E30 005 -T	76, 112 138, 141, 142, 144, 147, 148, 149, 150, 152, 154, 156, 158, 160, 162, 254.
Maintenance kit	DUO 5 M DUO 5 MC	PK E31 004 -T	138, 144, 162.
Set of vanes	DUO 5 M	PK E38 008 -T	7, 8, 9, 10.
	DUO 5 MC	PK E38 009 -T	7, 8, 9, 10.
Overhaul kit	DUO 5 M	PK E32 008 -T	PK E30 005 -T, 7, 8, 9, 10, 32, 44, 51, 100, 102, 106, 110, 114, 208.
	DUO 5 MC	PK E32 006 -T	PK E30 005 -T, 7, 8, 9, 10, 32, 44, 51, 100, 102, 106, 110, 114, 208.
Vacuum safety valve	DUO 5 M DUO 5 MC	PK E34 004 -T	30, 32, 34, 70, 100, 106, 108, 147, 152, 154, 160, 188, 204, 208, 220, 250.
Pumping system, complete and tested with P3	DUO 5 M	PK E33 001 -T	4.1
Pumping system, complete and tested with D1	DUO 5 M	PK E33 004 -T	4.1
Pumping system, complete and tested with F4	DUO 5 M	PK E33 002 -T	4.1
Pumping system, complete and tested with F4	DUO 5 MC	PK E33 003 -T	4.1
Exhaust valve, stage II	DUO 5 M DUO 5 MC	PK E35 002 -T	100, 102, 184, 204, 208.
Coupling ki	DUO 5 M	PK E36 005 -T	18, 20, 24, 184, 254.
	DUO 5 MC	PK E36 006 -T	18, 20, 24, 184, 254.

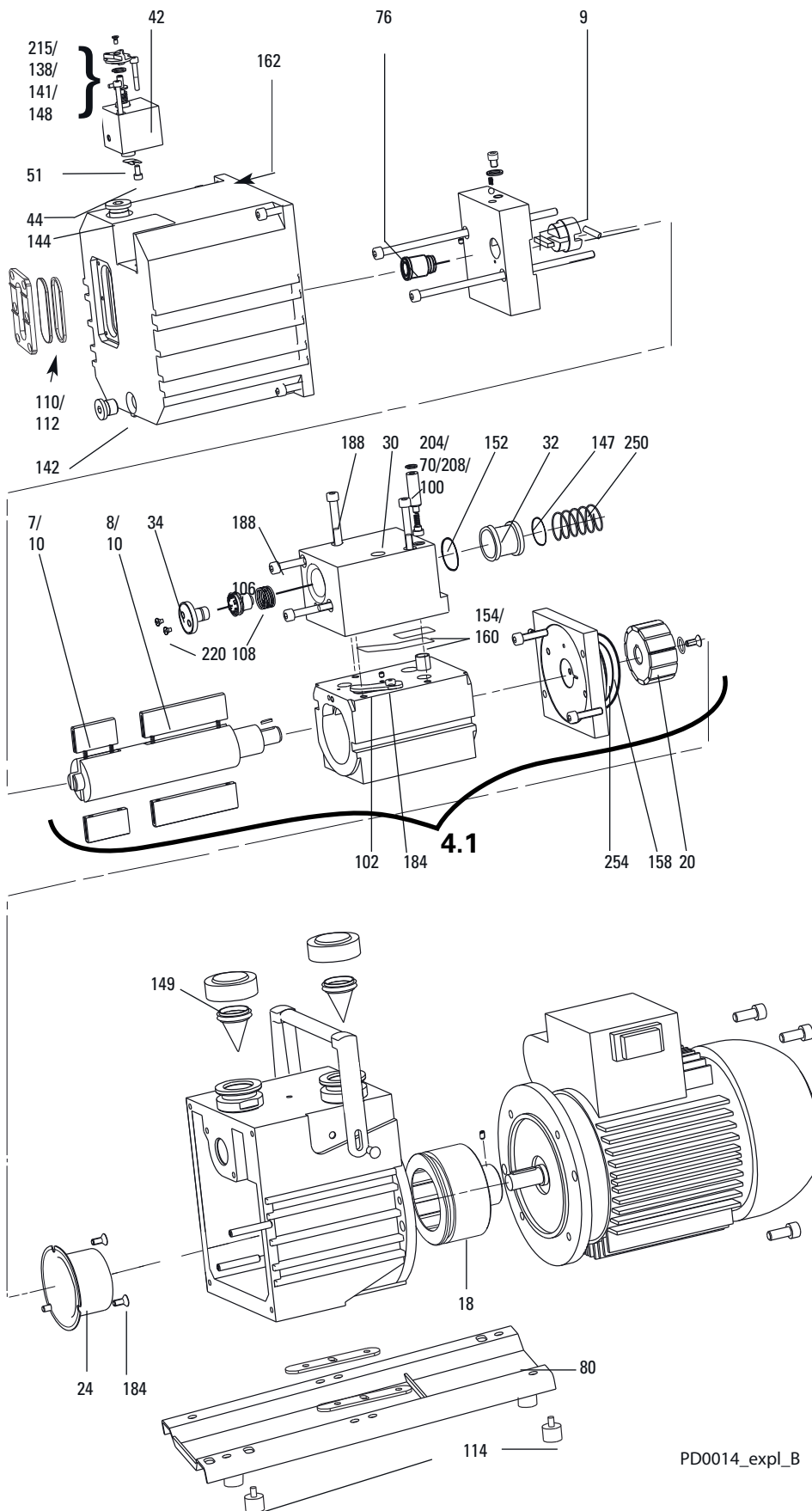

- 4.1 Pump cylinder, complete
- 7 Vanes, rough stage
- 8 Vanes, rough stage
- 9 Hydraulic vanes
- 10 Compression spring
- 18 Magnetic coupling, drive side
- 20 Magnetic coupling, pump side
- 24 Can
- 30 Housing, vacuum safety valve
- 32 Valve plate, vacuum safety valve
- 34 Valve cover, vacuum safety valve
- 42 Gas ballast valve housing (further parts see Section 7.3.)
- 44 Silencer nozzle
- 51 Plate spring
- 70 Valve trap
- 76 Rapid action coupling
- 80 Base plate
- 100 Valve buffer
- 102 Valve plate
- 106 Hydraulic piston
- 108 Compression spring
- 110 Sight glass
- 112 Sight glass seal
- 114 Rubber foot
- 138 O-ring (GB valve)
- 141 O-ring (GB valve)
- 142 O-ring
- 144 O-ring
- 147 O-ring
- 148 O-ring (GB valve)
- 149 O-ring
- 152 O-ring
- 154 O-ring
- 158 O-ring
- 160 O-ring
- 162 O-ring
- 184 Allan head screw
- 188 Allan head screw
- 204 Circlip
- 208 Compression spring
- 215 Compression spring GB valve
- 220 Screw
- 250 Compression spring for vacuum safety valve
- 254 O-ring

Fig. 15: Exploded view DUO 5 M/MC

12 Accessories

Further detailed accessories are contained in the Pfeiffer Vacuum printed or Online Catalogue.

Designation	DUO 5 M
Barretter actuation unit 3TF	P 4768 051 FQ
KAS 16, condensate separator for pumping speeds from 1.25 to 5 m ³ /h	PK Z10 003
ONF 16, oil mist filter for pumping speeds of up to 1.25-5 m ³ /h	PK Z40 003
STP 16, dust separator, single-stage for minor contamination	PK Z60 203
SAS 16, DN 16 ISO-KF, polyester filter	PK Z60 506
ZFO 16, zeolite trap	PK Z70 003
Operational monitoring unit 3 - operating fluid level, operating fluid temperature, exhaust pressure	PK 196 141 -T
Operational monitoring unit 2 - operating fluid level, operating fluid temperature	PK196142-T
Operating fluid level monitoring 1 - operating fluid level	PK 196 157-T
Oil return unit from ONF 16 to DUO 5 M, from ONF 25 to DUO 10 M, from ONF 25 L to DUO 20 M, standard version	PK 196 172-T
Operational monitoring - oil pressure switch	PK 196 484-T
P3, mineral oil, 1 l	PK 001 106-T
P3, mineral oil, 5 l	PK 001 107-T
P3, mineral oil, 20 l	PK 001 108-T

Designation	DUO 5 MC
Barretter actuation unit 3TF	P 4768 051 FQ
Operational monitoring unit 3 - operating fluid level, operating fluid temperature, exhaust pressure	PK 196 141 -T
Operational monitoring unit 2 - operating fluid level, operating fluid temperature	PK196142-T
Operating fluid level monitoring 1 - operating fluid level	PK 196 157-T
Operational monitoring - oil pressure switch	PK 196 484-T
F4, Perfluorpolyether, 0.25 l	PK 005 885-T
F4, Perfluorpolyether, 0.5 l	PK 005 886-T
F4, Perfluorpolyether, 1 l	PK 005 887-T

13 Technical data

Parameter	DUO 5 M, 1-phase motor	DUO 5 MC, 1-phase motor
Flange (in)	DN 16 ISO-KF	DN 16 ISO-KF
Flange (out)	DN 16 ISO-KF	DN 16 ISO-KF
Pumping speed at 50 Hz	5 m ³ /h	5 m ³ /h
Pumping speed at 60 Hz	6 m ³ /h	6 m ³ /h
Ultimate pressure with gas ballast	$\leq 2 \cdot 10^{-2}$ mbar	$\leq 2 \cdot 10^{-2}$ mbar
Ultimate pressure without gas ballast	$\leq 5 \cdot 10^{-3}$ mbar	$\leq 5 \cdot 10^{-3}$ mbar
Rotation speed at 50 Hz	1500 rpm	1500 rpm
Rotation speed at 60 Hz	1800 rpm	1800 rpm
Leak rate safety valve	$\leq 1 \cdot 10^{-4}$ mbar l/s	$\leq 1 \cdot 10^{-4}$ mbar l/s
Emission sound pressure level without gas ballast	≤ 57 dB (A)	≤ 57 dB (A)
Rated power 50 Hz	0.37 kW	0.37 kW
Rated power 60 Hz	0.37 kW	0.37 kW
Mains requirement: voltage 50 Hz	200-240 ($\pm 5\%$) V	200-240 ($\pm 5\%$) V
Mains requirement: voltage 60 Hz	208-240 ($\pm 5\%$) V	208-240 ($\pm 5\%$) V
Switch	Yes, with 2 m mains cable and safety plug	Yes, with 2 m mains cable and safety plug
Operating fluid filling	0.75 l	0.75 l
Weight	25 kg	25 kg

Parameter	DUO 5 M, 3-phase motor	DUO 5 MC, 3-phase motor
Flange (in)	DN 16 ISO-KF	DN 16 ISO-KF
Flange (out)	DN 16 ISO-KF	DN 16 ISO-KF
Pumping speed at 50 Hz	5 m ³ /h	5 m ³ /h
Pumping speed at 60 Hz	6 m ³ /h	6 m ³ /h
Ultimate pressure with gas ballast	$\leq 2 \cdot 10^{-2}$ mbar	$\leq 2 \cdot 10^{-2}$ mbar
Ultimate pressure without gas ballast	$\leq 5 \cdot 10^{-3}$ mbar	$\leq 5 \cdot 10^{-3}$ mbar
Rotation speed at 50 Hz	1500 rpm	1500 rpm
Rotation speed at 60 Hz	1800 rpm	1800 rpm
Leak rate safety valve	$\leq 1 \cdot 10^{-4}$ mbar l/s	$\leq 1 \cdot 10^{-4}$ mbar l/s
Emission sound pressure level without gas ballast	≤ 55 dB (A)	≤ 55 dB (A)
Rated power 50 Hz	0.25 kW	0.25 kW
Rated power 60 Hz	0.35 kW	0.35 kW
Mains requirement: voltage 50 Hz	190-210/330-365 ($\pm 5\%$) V	220-240/380-420 ($\pm 5\%$) V
Mains requirement: voltage 60 Hz	200-230/360-400 ($\pm 5\%$) V	250-277/440-480 ($\pm 5\%$) V
Switch	No	No
Operating fluid filling	0.75 l	0.75 l
Weight	19 kg	19 kg

13.1 Dimensions

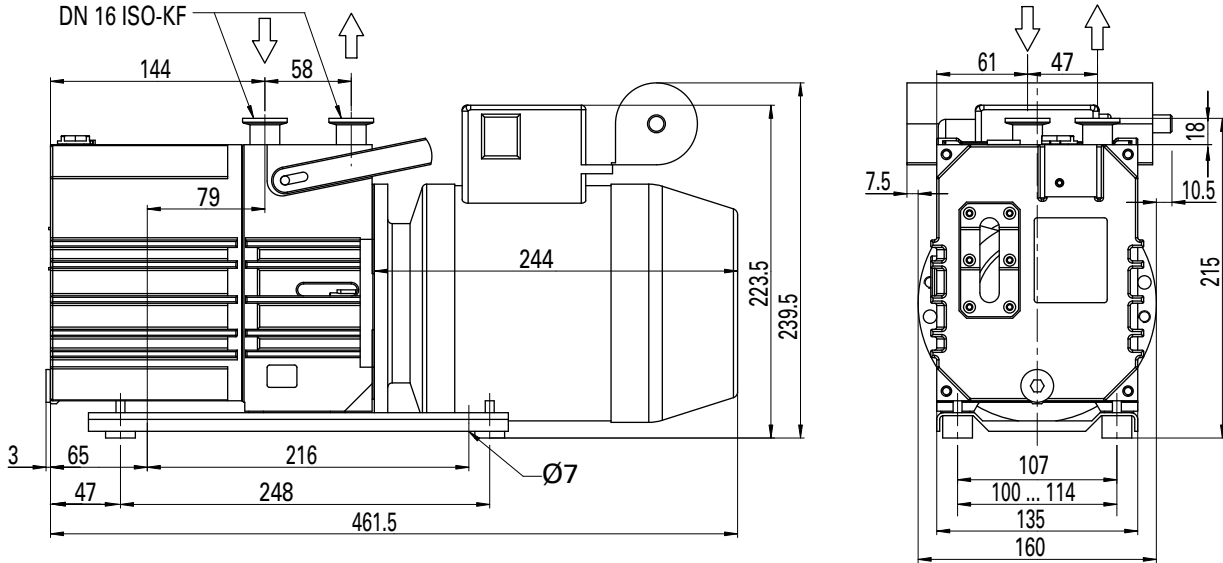

Fig. 16: DUO 5 M, 1-phase motor, 95-120 V, 50 Hz ; 105-120 V, 60 Hz

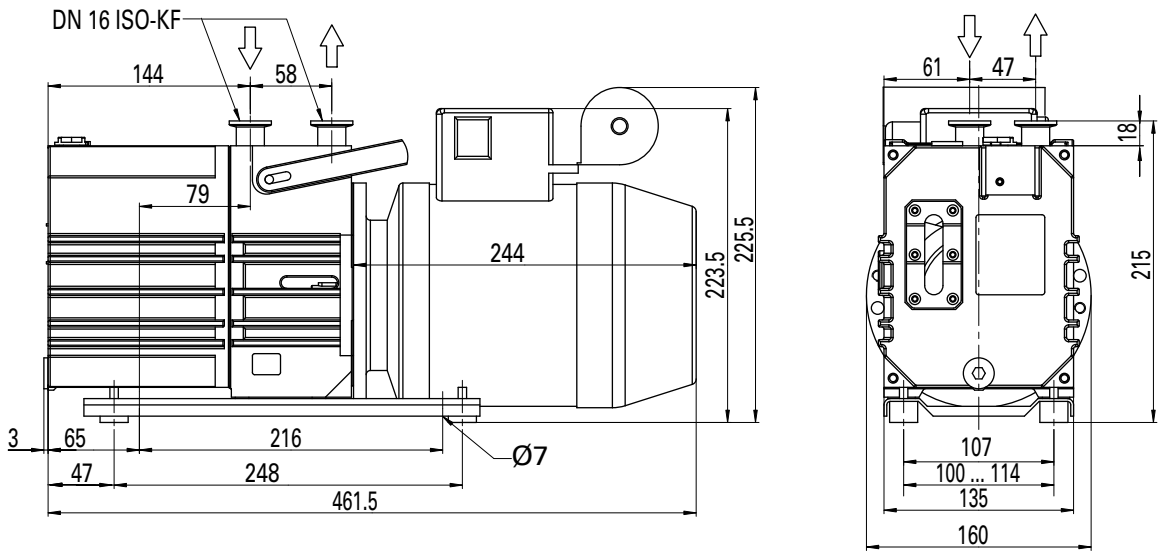

Fig. 17: DUO 5 M, 1-phase motor, 200-240 V, 50 Hz ; 208-240 V, 60 Hz

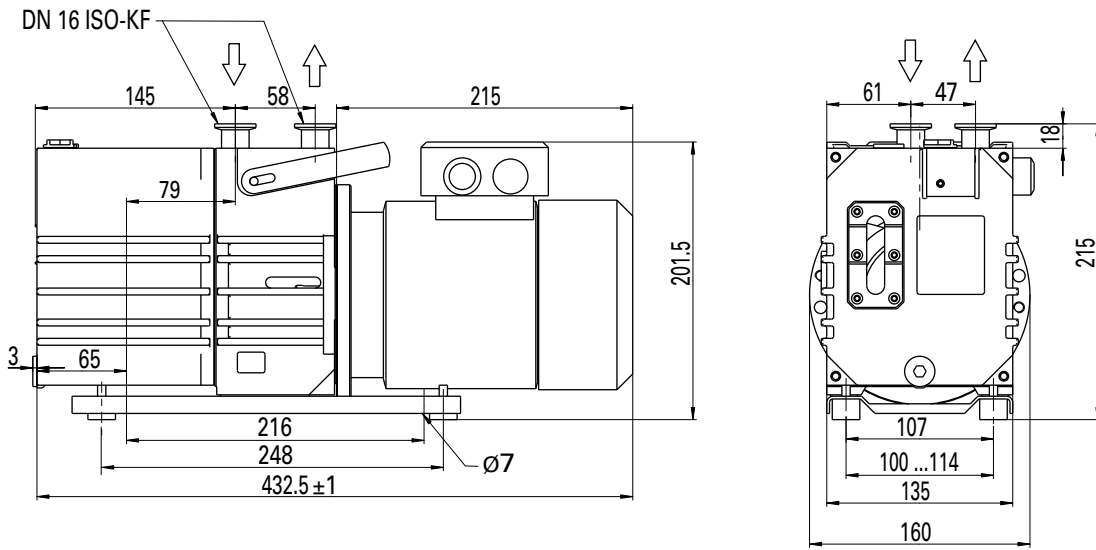

Fig. 18: DUO 5 M, 3-phase motor, 220-240/380-420 V, 50 Hz ; 250-277/440-480 V, 60 Hz



Declaration of conformity

according to the EC directive:

- **Machinery 2006/42/EC (Annex II, no. 1 A)**

We hereby declare that the product cited below satisfies all relevant provisions of EC directive "Machinery" **2006/42/EC**.

In addition, the product cited below satisfies all relevant provisions of EC directive "Electromagnetic Compatibility" **2004/108/EC**.

The agent responsible for compiling the technical documentation is Mr. Sebastian Oberbeck, Pfeiffer Vacuum GmbH, Berliner Straße 43, 35614 Asslar.

DuoLine®/DuoLine™

DUO 5 M/MC

Guidelines, harmonised standards and national standards and specifications which have been applied:

DIN EN ISO 12100 : 2011-03	DIN EN 61010 : 2002	DIN EN 61000-6-3 : 2007
DIN EN 1012-2 : 1996	DIN EN 61000-6-1 : 2007	DIN EN 61000-6-4 : 2007
DIN EN ISO 13857 : 2008	DIN EN 61000-6-2 : 2006	

Signatures:

Pfeiffer Vacuum GmbH
Berliner Straße 43
35614 Asslar
Germany

(M.Bender)
Managing Director

(Dr. M. Wiemer)
Managing Director

CE/2011