



Penta 20/35

Rotary Vane Pump

Operating Instructions

Table of contents

1	About this manual	3
1.1	Validity	3
1.2	Conventions	3
2	Safety	5
2.1	Safety precautions	5
2.2	Protective equipment	5
2.3	Proper use	6
2.4	Improper use	6
3	Transport and storage	6
3.1	Transport	6
3.2	Storage	7
4	Product description	8
4.1	Product identification	8
4.2	Function	9
5	Installation	10
5.1	Setting up the pump	10
5.2	Connecting the vacuum side	11
5.3	Connecting the exhaust side	11
5.4	Connecting to the mains power supply	11
5.5	Make remote connection	14
5.6	Filling up the operating fluid	15
5.7	Operations monitoring (Option)	16
5.8	Fitting the ONF and the oil return line (option)	17
6	Operation	18
6.1	Before switching on the pump	18
6.2	Switching on the pump	18
6.3	Pumping condensable vapours	19
6.4	Switching off	20
7	Maintenance	21
7.1	Precautions	21
7.2	Changing the operating fluid	22
8	Decommissioning	24
8.1	Shutting down for longer periods	24
8.2	Re-starting	24
8.3	Disposal	24
9	Malfunctions	25
9.1	Rectifying malfunctions	26
10	Service	27
11	Spare parts	28
12	Accessories	29
13	Technical data	30
13.1	Dimensions	31
	Declaration of conformity	32

1 About this manual

1.1 Validity

This operating manual is for customers of Pfeiffer Vacuum. It describes the functioning of the designated product and provides the most important information for safe use of the unit. The description follows applicable EU guidelines. All information provided in this operating manual refer to the current state of the product's development. The documentation remains valid as long as the customer does not make any changes to the product.

Up-to-date operating instructions can also be downloaded from www.pfeiffer-vacuum.com.

Applicable documents

Penta 20/35	Operating instructions
Declaration of Conformity	Part of this document
Operating instructions for accessories (order-specifically)	see section "accessories"

*also available via www.pfeiffer-vacuum.com

For information about other certifications, if applicable, please see the signet on the product or:

- www.tuvdotcom.com
- TUVdotCOM-ID 0000021320

1.2 Conventions

Safety instructions

The safety instructions in Pfeiffer Vacuum operating manuals are the result of risk evaluations and hazard analyses and are oriented on international certification standards as specified by UL, CSA, ANSI Z-535, SEMI S1, ISO 3864 and DIN 4844. In this document, the following hazard levels and information are considered:

DANGER
Immediate danger Death or very severe injuries can occur.
WARNING
Possible danger Injuries or severe property damages can occur.
CAUTION
Possible danger Injuries or property damages can occur.
NOTE
Command or note Command to perform an action or information about properties, the disregarding of which may result in damage to the product.

Pictograph definitions



Prohibition of an action or activity in connection with a source of danger, the disregarding of which may result in serious accidents.



Warning of a displayed source of danger in connection with operation of the unit or equipment.



Command to perform an action or task associated with a source of danger, the disregarding of which may result in serious accidents.

Instructions in the text

→ Work instruction: here you have to do something.

Symbols used

The following symbols are used consistently throughout in all illustrations:

- ① Vacuum flange
- ⊖ Exhaust flange
- Ⓜ Gas ballast valve
- ⚡ Power connection

2 Safety

2.1 Safety precautions



NOTE

Duty to inform

Each person involved in the installation, operation or maintenance of the vacuum pump must read and observe the safety-related parts of these operating instructions.

→ The operator is obligated to make operating personnel aware of dangers originating from the vacuum pump, the pumped medium and the entire system.



NOTE

Installation and operation of accessories

Pfeiffer Vacuum pumps can be equipped with a series of adapted accessories. The installation, operation and maintenance of connected devices are described in detail in the operating instructions of the individual components.

→ For information on order numbers of components, see "Accessories".

→ Use original accessory parts only.

- Do not expose any body parts to the vacuum.
- Observe the safety and accident prevention regulations.
- Check regularly that all safety precautions are being complied with.
- Do not carry out any unauthorised modifications or conversions to the pumps.
- Depending on the operating and ambient conditions, the surface temperature of the pumps may rise above 70 °C. Use suitable finger guards if necessary.
- When returning the pumps to us please note the instructions in the Service section.

2.2 Protective equipment

Determined situations concerning the handling of vacuum pumps require wearing of personal protective equipment. The owner, respectively the employer are obligated to provide adequate equipment to any operating persons.



DANGER

Danger to health by hazardous substances during maintenance or installation

Depending on the process vacuum pumps, components or operating fluids can be contaminated by toxic, reactive or radioactive substances.

→ Wear adequate protective equipment during maintenance and repairs or in case of reinstallation.



CAUTION

Risk of injury through hot surfaces

Vacuum pumps can become hot during operation.

→ Allow the pump to cool before maintenance and repairs.

→ If necessary wear protective gloves according to directive EN 420.



WARNING

Increased noise emission!

Increased noise emission can occur within a limited area surrounding the vacuum pump.

→ Provide noise protection or

→ wear hearing protection.

2.3 Proper use



NOTE

CE conformity

The manufacturer's declaration of conformity becomes invalid if the operator modifies the original product or installs additional components.

→ Following installation into a plant and before commissioning, the operator must check the entire system for compliance with the valid EU directives and reassess it accordingly.

- The vacuum pump may only be used to generate a vacuum.
- Installation, operating and maintenance regulations must be complied with.
- Other accessories, than those described in this manual, must not be used without the agreement of Pfeiffer Vacuum.

2.4 Improper use

Improper use will cause all claims for liability and warranties to be forfeited. Improper use is deemed to be all use for purposes deviating from those mentioned above, especially:

- Pumping of corrosive gases.
- Pumping of explosive media.
- Operation in potentially explosive areas.
- Pumping of gases containing impurities such as particles, dusts and condensate; note the vapour compatibility levels of the pump.
- Pumping of substances that tend to sublime.
- Use of the vacuum pump to generate pressure.
- Pumping of liquids.
- The use of operating fluids not specified by Pfeiffer Vacuum.
- Connection to pumps or units which are not suitable for this purpose according to their operating instructions.
- Connection to units which have exposed voltage-carrying parts.
- The operation of the devices in potentially radioactive areas.

3 Transport and storage

3.1 Transport

- Remove the locking cap from the vacuum and exhaust flange immediately before connecting!
 - Check the cone strainer, paying attention to the O-ring.
- Use only the eye bolt on the top side of the pump to lift the pump.

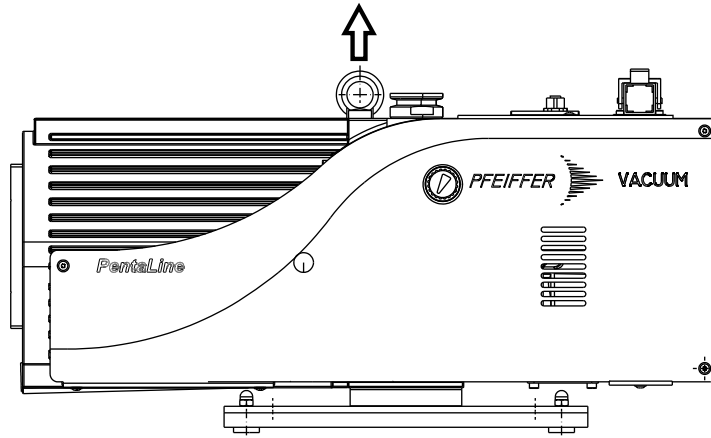

Fig. 1: Transporting the pump

3.2 Storage

- Check that all the openings on the pump are securely closed.
- Store the pump in a cool, dry place; preferably at temperatures between $-10\text{ }^{\circ}\text{C}$ and $+40\text{ }^{\circ}\text{C}$.
 - For a longer period of storage, seal the pump in a PE bag with drying agents enclosed.
 - For a period of storage longer than two years, it is recommended to change the operating fluid before using the pump.

4 Product description

4.1 Product identification

To correctly identify the product when communicating with Pfeiffer Vacuum, always have the information from the rating plate available.

- Pump model and model number
- Serial number
- Type and amount of operating fluid
- Date of manufacture

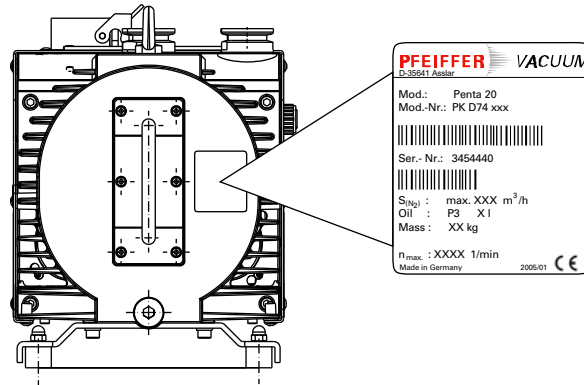

Fig. 2: Product identification on the rating plate

Scope of delivery

- Pump with drive unit
- Operating fluid P3 (for standard pump)
- Cone strainer and centering ring with O-ring
- Locking cap for vacuum and exhaust flange
- Remote plug with bridge (On/Off function)
- Operating instructions

Pump types

Parameter	Penta 20	Penta 35
Pumping speed, max.	22 m ³ /h	34 m ³ /h
Max. power consumption: pump	0.99 kW	1.475 kW

4.2 Function

The PentaLine® pumps are two-stage rotary shutter pumps with an electronic drive concept for all coarse and fine vacuum applications. Since the drive is coupled to the pump system by a contactless mechanism, it suffers no mechanical wear and is completely maintenance-free. The pumps are equipped with a vacuum safety valve that vacuum seals the vacuum chamber and vents the pump at the same time when the pump is at a standstill.



- 1 Vacuum flange
- 2 Exhaust flange
- 4 Casing panel
- 6 Base
- 32 Mains connection
- 50.1 Remote connection
- 50.2 Remote plug with bridge
- 161 Gas ballast valve
- 162 Connection for operating fluid return line
- 172 Operating fluid filler screw
- 172a Operating fluid drain screw

Fig. 3: Penta 10/20/35

5 Installation

5.1 Setting up the pump

Installation location

When installing the pump, observe the following conditions:

- Consider the load-bearing capacity of the installation site.
- Maximum installation altitude 1000 m (above mean sea level)
- Permissible ambient temperature: +12 ... 40°C
- Maximum relative humidity 85%

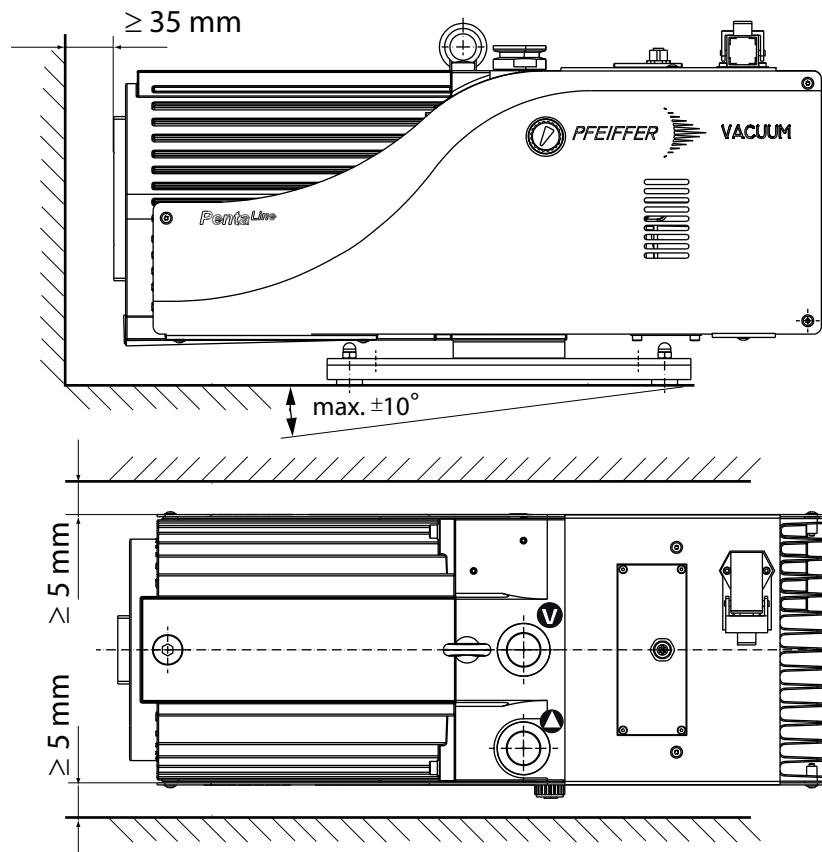

Fig. 4: Setting up the pump

- Fill up with operating fluid before operating the first time (see p. 15, chap.).
 - Amount and type according to rating plate
- Always place the pump on a firm, even surface.
 - Where stationary installation is involved, anchor the pump on site.
- When installing the pump in a closed housing, ensure there is sufficient air circulation.
 - Sightglass and gas ballast valve must be visible and readily accessible.
 - Voltage and frequency information given on the motor rating plate must be visible.

5.2 Connecting the vacuum side

- Remove locking cap from the vacuum flange;
 - pay attention to the cone strainer and the respective O-ring in the intake port.
- The connection between the pump and the recipient should be kept as short as possible.
 - Depending on the pump type, use metallic hoses or PVC hoses with flange connections.
 - Separators, filters etc. may be installed upstream to protect the pump (see accessories). However, please observe the loss of pumping capacity due to the conductivity of the accessories.

5.3 Connecting the exhaust side



CAUTION

High pressure in the exhaust line!

Danger of damage to the seals and danger of the pump bursting.

- Install the line without shut-off valves on the exhaust side.
- If there is danger of a build-up of excess pressure (> 1500 mbar abs.) in the lines, observe all official accident prevention safety regulations.
- If the exhaust gases are being extracted, the exhaust pressure must be at least
- 250 mbar greater than the pressure at the intake side.

- Choose the cross-section of the exhaust line to be at least the size of the nominal connection diameter of the vacuum pump's exhaust connection.
- Piping to the pump must be suspended or supported.
 - Physical forces from the piping system must not be allowed to act on vacuum pumps.
- Lay piping from the pump sloping downward so that no condensate can flow back into the pump; otherwise fit a condensate separator.
 - If an air trap is created in the system, then a device for draining condensation water must be provided at the lowest point.



WARNING

Emission of toxic substances from the exhaust!

Danger of poisoning from emitted gases or vapours, which can be detrimental to health and/or can pollute the environment, depending on the particular application.

- Comply with the applicable regulations when working with toxic substances.
- Only officially approved filter systems may be used to separate and remove these substances.

5.4 Connecting to the mains power supply

The input voltage may lie in the ranges 100 ... 120 VAC (50/60 Hz) and 200 ... 240 VAC (50/60 Hz). The pump is preset ex works to a voltage range of 200 ... 240 VAC. In case of another supply voltage the input has to be switched over accordingly.



DANGER

Voltage-bearing elements

Danger to life from electric shock.

- The electrical connection can be carried out only by trained and authorised electricians.
- Disconnect the power supply and secure it against being switched back on.
- Ensure the system is adequately earthed.



WARNING

Safe electrical installation
 Safe operation after installation is the responsibility of the operator. The pump and its electrical equipment have no lock-out/tag-out device and no emergency off device.

- Make sure that the system is integrated in an emergency off safety circuit.
 - If an emergency off situation is triggered, the voltage supply must be immediately interrupted.
- Consult Pfeiffer Vacuum for special requirements.



CAUTION

Excess voltage!
 Danger of destroying the motor.

- Power connections must comply with local regulations. Voltage and frequency information given on the motor rating plate must correspond to the mains voltage and frequency values.
- To protect the motor and supply cable in case of malfunction, mains fuse protection must be implemented.

Connecting to the mains power supply

Permissible input voltage range:

- 100 ... 120 VAC (± 10 %)
- 200 ... 240 VAC (± 10 %)

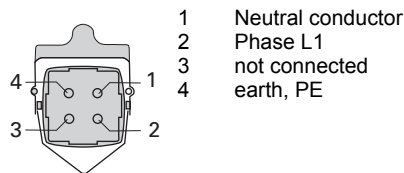
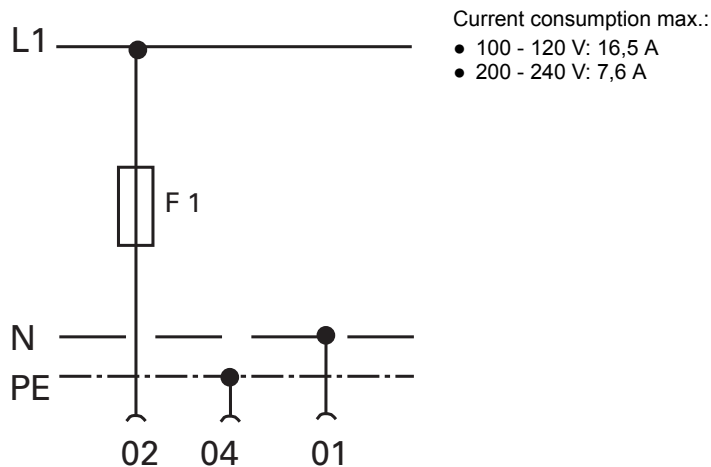

Fig. 5: Power supply pin assignment; Type: Harting Han 3A

The drive electronics ensures automatically the correct direction of rotation of the pump.

Fuse protection

- To protect the motor in case of malfunction, carry out fuse protection in accordance with the regional regulations.
 - Select a fuse with slow characteristics.



Changing the voltage range

- The mains voltage must be determined on-site each time before the pump is installed or moved to a different location.

**NOTE****Overvoltage!**

An incorrect voltage range setting can damage the motor.

- Disconnect the pump from the power supply.
- Only change the voltage range when the pump is disconnected from the power mains.

A voltage selector switch below the connector plate enables toggling between the two voltage ranges. The factory default setting is 200 ... 240 VAC.

S Voltage selector switch

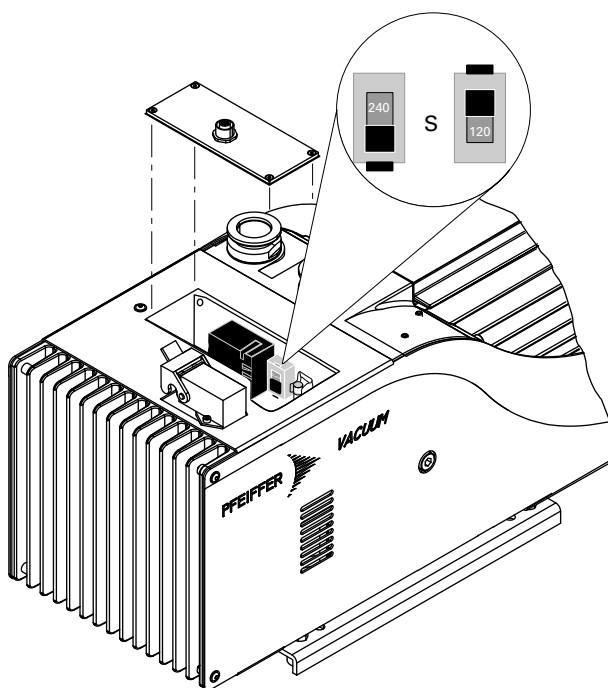

Fig. 6: Changing the voltage range for the power supply

- Disconnect the pump from the power supply.
- Remove the connector plate and set the voltage selector switch "S" to the desired voltage range.

Monitoring of the operation conditions

The pump features the following functions for monitoring the pump components:

- Monitoring the temperature of the electronics
 - Resetting by briefly removing the remote connector or by disconnecting from the mains ("Off/On").
- Monitoring the internal motor winding temperature
 - Resetting by briefly removing the remote connector or by disconnecting from the mains ("Off/On"), followed by pump cooling.
- Surge current shut-down of electronics
 - Resetting by briefly removing the remote connector or by disconnecting from the mains ("Off/On").

5.5 Make remote connection

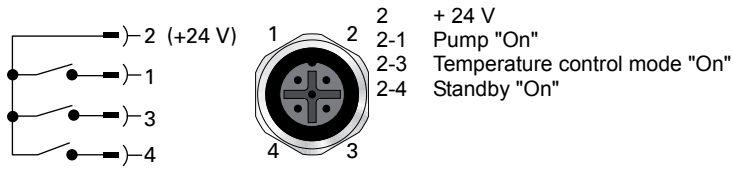

Fig. 7: Remote connector pin assignment M12 socket, 4-pin (A-coded)

5.6 Filling up the operating fluid

The type and amount of operating fluid should be visible on the pump's rating plate for every rotary vane pump.

The delivery consignment for the **standard pump** contains sufficient operating fluid for one filling. The use of other operating fluids requires prior authorisation from Pfeiffer Vacuum.

Permissible operating fluids

- P3 (Standard operating fluid)
- D1 (for special applications and higher operating temperature)
 - Ultimate pressure measured with gas type dependent gauge: $< 5 \cdot 10^{-2}$ mbar



NOTE

Use approved operating fluids only!

The use of operating fluids that have not been approved by Pfeiffer Vacuum shall result in a limited warranty. In such cases, it is not possible to guarantee that product-specific performance data will be achieved.

→ Prior consultation is required before using other application-specific operating fluids.

Filling up the operating fluid

- Unscrew operating fluid filler screw 172.
- Fill up operating fluid.
 - Correct filling level during operations: within the markings at the sightglass frame.

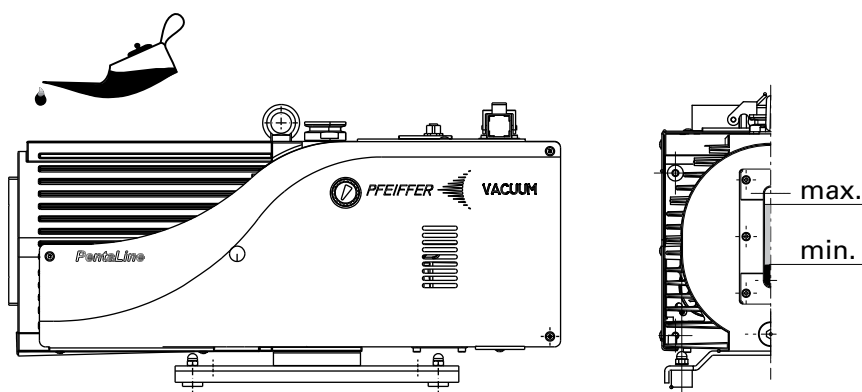

Fig. 8: Filling up the operating fluid

- Screw in operating fluid filler screw 172.
- Check operating fluid level only when the pump is warm and running; close
 - vacuum flange and gas ballast valve to do so,
 - Check operating fluid daily in non-stop operation, otherwise whenever the pump is switched on. Refilling is possible when the pump is in final vacuum operation.

5.7 Operations monitoring (Option)

A pressure switch can be installed on the side of the support to monitor the operating fluid pressure of the rotary vane pump during operations. By pressure drop and when the pump is at rest, the contact of the pressure switch opens. The signal can be used to control external valves.

Switching voltage:	5 ... 250 Volt (potential-free)
Current, max.	2 Amp.
Protection class	IP 55

1 + 2 closers = pressureless open

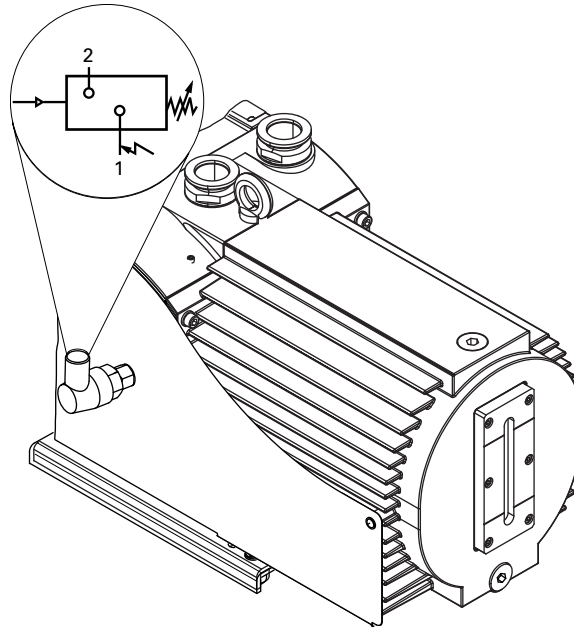

Fig. 9: Pressure switch; installation location and circuit diagram

5.8 Fitting the ONF and the oil return line (option)

For frequent pumping at higher intake pressures the use of an oil mist filter with oil return line is recommended in order to reduce the discharge of oil mist.

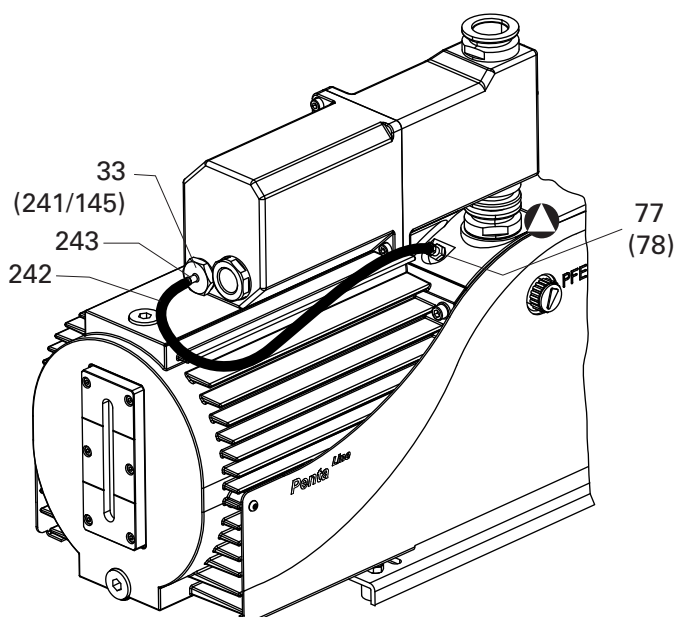

Fig. 10: Fitting the oil mist filter ONF 25 XL

- Position the ONF on the small flange on the exhaust side of the pump and fit using the tension ring (accessory); take care with the centering ring.
- Screw in hose nipple 241 in place of the operating fluid drain screw; take care with O-ring.
- Fit operating fluid return hose 242 at both sides on the hose nipples and tighten with hose clip 243 at the ONF side.

6 Operation

6.1 Before switching on the pump

- Check the operating fluid level in the sightglass.
- Compare the voltage and frequency information on the rating plate with the mains voltage and frequency values.
- Check that the exhaust connection allows free flow (max. permissible pressure 1.5 bar absolute).
 - Activate the shut-off valves in such a way that they open before or at the same time as the pump is started.
- Protect the pump sufficiently from taking in contaminants by means of suitable precautions (e.g. dust filters); if necessary, check operating fluid regularly or replace at shorter intervals.

6.2 Switching on the pump

The pump can be switched on in any pressure range between atmospheric and ultimate pressure.

No special precautions are necessary when pumping dry gases. In order to attain the lowest possible ultimate pressures, the gas ballast valve should be closed.



CAUTION

Hot surface!

Danger of burns if hot parts are touched. Depending on the operating and ambient conditions, the surface temperature of the pump may rise above 70 °C.

→ In this case, use suitable finger guards.

- Switch-on pump via remote plug with bridge 50.2.
 - The run-up time to attain final rotation speed is approx. 15 s.
- Switch on the pump with the vacuum flange closed and allow to warm up for 30 minutes.

Standby

The pump can be operated with reduced rotation speed (standby) during process breaks or in cases with small load. Thus the power consumption of the pump is reduced and the operating temperature of the pump lowered.

- Bridge Pin 2 and Pin 4 at remote connection 50.1 (see p. 14, chap. 5.5);
 - use customized remote plug (see p. 29, chap. 12).



NOTE

Improper operating status of the pump!

Simultaneously standby and temperature control mode leads to an increased operating temperature and therefore to switching off the pump.

→ In addition, do not use gas ballast while the pump is on standby.

6.3 Pumping condensable vapours

Should the process gases contain condensable gases present at high percentages, the rotary vane pump must be operated with gas ballast (i.e. with an open gas ballast valve).



CAUTION

Bad final vacuum and damage to the pump!

Danger of condensation and corrosion due to exceeding the water vapour compatibility during operation without gas ballast or in case of insufficient supply of flushing gas.

- Only pump vapours when the pump is warm and the gas ballast valve is open.
- When the process has been completed, allow the pump to continue running for about 30 minutes with the vacuum flange closed and the gas ballast open for operating fluid regeneration purposes.

Gas ballast valve, standard version

To avoid condensation in the pump when pumping condensable vapours, air is periodically fed into the working chamber at the beginning of the compression phase via the gas ballast valve 161.

- Open gas ballast valve; to do so, turn cap 43 on the gas ballast valve 161 so that the two holes line up.

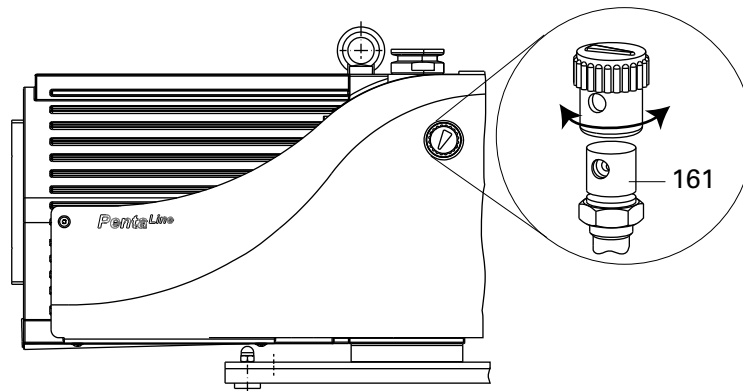

Fig. 11: Standard version 161 of gas ballast valve

Temperature control mode

Operating the pump in temperature control mode will further improve the discharge of liquids when pumping large volumes of condensable vapours. The fan is temporarily switched off to increase the operating temperature of the pump.

- Open gas ballast valve; to do so, turn cap 43 on the gas ballast valve 161 so that the two holes line up.
- Bridge Pin 2 and Pin 3 at remote connection 50.1 to switch on the temperature control mode;
 - use customized remote plug (see p. 29, chap. 12).

6.4 Switching off

The pump can be switched off in any pressure range.

Rotary vane pumps have an integrated safety valve on the intake side. If the differential pressure between the exhaust side and the intake side is ≥ 250 mbar, then the valve closes automatically and vents the pump when the pump is switched off.

→ Switch-off pump by disconnecting from mains or via remote bypass 50.2.

Venting the vacuum chamber



CAUTION

Danger of backflow of operating fluid into the intake line!

Contamination of the connected vacuum system!

- Vent the vacuum chamber within 30 s, regardless of the chamber size.
- For a longer venting process, use an additional shut-off valve and shut off the intake line after switching off the pump.

Maintaining the vacuum in the chamber



CAUTION

Danger of backflow of operating fluid into the intake line!

Contamination of the connected vacuum system!

- Because the safety valve of the pump is not suitable for longer-term sealing, install an additional shut-off valve in the intake line.
- Shut off the intake line immediately after switching off the pump.

7 Maintenance

7.1 Precautions



WARNING

Pump parts may be contaminated from pumped media!

Danger of poisoning due to contact with harmful substances.

- Decontaminate the pump before carrying out any maintenance work.
 - In the event of contamination, take suitable safety precautions to prevent your health from being harmed by any dangerous substances.
-
- Turn off the vacuum pump, vent to atmospheric pressure and allow to cool, if necessary.
 - Disconnect the drive motor from the mains and secure it so that it cannot be switched on.
 - Only dismantle the pump as far as necessary in order to repair defects.
 - Dispose of used operating fluid in compliance with local regulations.
 - When using synthetic operating fluids or working with toxic substances or substances contaminated with corrosive gases, the relevant instructions governing their use must be observed.
 - Use only alcohol or similar agents for cleaning pump parts.

Checklist for inspection, maintenance and overhaul

Certain repair and overhaul work should only be performed by Pfeiffer Vacuum Service (PV). Pfeiffer Vacuum will be released from all warranty and liability claims if the required intervals for inspection, maintenance, or overhaul are exceeded or inspection, maintenance, repair or overhaul procedures are not performed properly. This also applies if replacement parts other than Pfeiffer Vacuum OEM replacement parts are used.

Activity	daily	as required; at least annually	as required; at least every 2 years	as required; at least every 4 years
Check operating fluid level	X			
Visual inspection (leak-tightness/oil leaks)	X			
Check filter insert of external oil mist filter (if existent)	X			
Change filter insert of external oil mist filter (if existent)		X		
Change operating fluid		X		
Cleaning the pump and renew the seals		X		
Clean gas ballast valve and silencer nozzle		X		
Clean the fan intake side		X		
Clean or change vacuum safety valve			X (PV)	
Clean or change exhaust valves			X (PV)	
Change vanes and hydraulic vane				X (PV)

Depending on the process, the required replacement intervals for lubricants and the intervals for inspection, maintenance and overhaul may be shorter than the guide values specified in the table. Consult with Pfeiffer Vacuum Service if necessary.

7.2 Changing the operating fluid

The changing interval for the operating fluid depends on the pump applications, but should be carried out once a year.



NOTE

Depending on the applications, Pfeiffer Vacuum recommends determining the exact service life of the operating fluid during the first year of operation.

The replacement interval may vary from the guide value specified by Pfeiffer Vacuum depending on the thermal and chemical loads, and the accumulation of suspended particles and condensation in the operating fluid.



WARNING

Hot operating fluid!

Danger of burns when draining due to contact with skin.

- Wear suitable protective clothing.
- Use a suitable collecting vessel.

- The level of deterioration of operating fluid P3 can be determined for clean processes with the colour scale (in accordance with DIN 51578); supplementary sheet PK 0219 BN on request or download it from the Internet.
- Suck off operating fluid from the pump through the operating fluid filler opening.
- Fill the specimen in a test tube or some similar vessel and test by holding against the light.
- Where discolouration is red brown (equivalent to 5 on the scale) change operating fluid.
- Switch off the pump.
- Unscrew operating fluid filler screw 172.
- Unscrew operating fluid drain screw 172a.

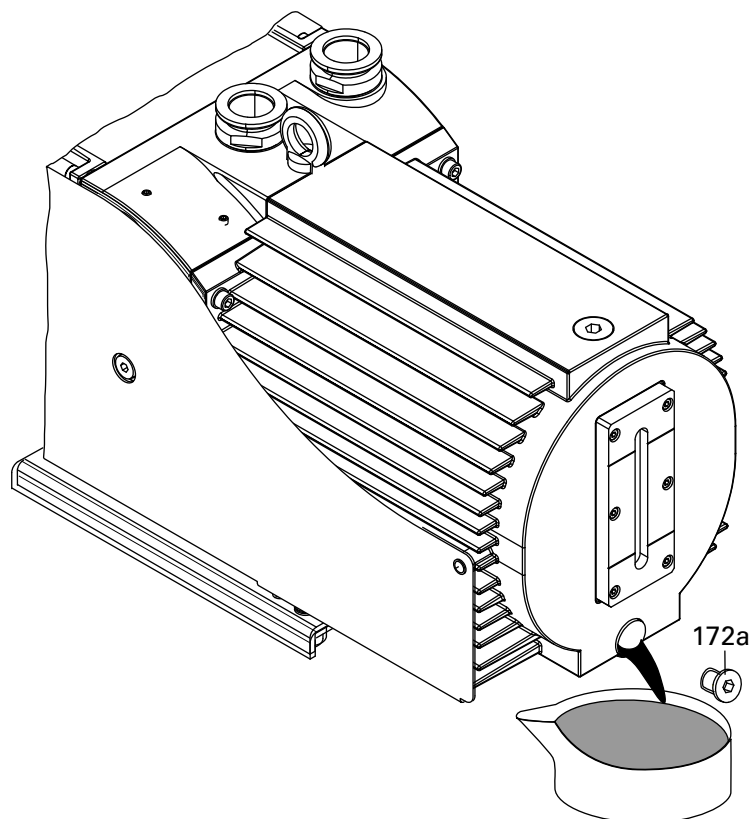

Fig. 12: Draining the operating fluid



WARNING

Operating fluid may contain toxic substances from the pumped media!

Danger of poisoning from the emission of harmful substances from the operating fluid.

→ Wear suitable protective clothing and respirators.

→ Dispose of operating fluid according to the local regulations

→ Screw in operating fluid drain screw 172a; pay attention to O-ring.

→ Screw in operating fluid filler screw 172.

→ Allow pump to run for a maximum of 5 seconds with the vacuum flange open.

→ Drain off remaining operating fluid.

– In case of serious contamination, the operating fluid will have to be changed several times (flushing):

Flushing

→ Fill up with operating fluid to the middle of the sight glass.

→ Operate the pump with the gas ballast open until the pump has warmed up.

→ Drain the operating fluid again and check for contamination, flush again if necessary.

→ Screw the operating fluid drain screw back in.

→ Fill up with operating fluid and check the filling level (*see p. 15, chap.).*



NOTE

Request safety data sheets for operating fluids and lubricants

from Pfeiffer Vacuum or download them from the Internet.

→ Dispose of operating fluid according to the local regulations.

8 Decommissioning

8.1 Shutting down for longer periods

Before shutting down the pump, observe the following procedure and adequately protect the pump system against corrosion:

- Switch off pump.
- Change operating fluid
- Start the pump and allow the pump to warm up.
- Switch off the pump.
- Fill up the pump with new operating fluid to the top edge of the sightglass.
- Close vacuum flange and exhaust flange with locking caps.
- Store the pump in a cool, dry place; preferably at temperatures between -10 °C and +40 °C.
 - For a longer period of storage, seal the pump in a PE bag with drying agents enclosed.
 - For a period of storage longer than two years, it is recommended to change the operating fluid before using the pump.
- Do not store pump in the vicinity of machines, lanes, etc., because strong vibrations can damage the rotor bearings.

8.2 Re-starting



CAUTION

Emission of operating fluid!

Danger of the operating fluid being emitted at the exhaust flange if overfilled.

- Drain the operating fluid to the normal level before restarting the pump.



CAUTION

Re-starting

The serviceability of the operating fluid without operation is a maximum of 2 years. Before restarting after a shut-down of **2 years or longer**, carry out the following work.

- Replace the operating fluid.
- Replace the elastomer parts, with reference to DIN 7716 and the manufacturer's specifications.
- Follow the maintenance instructions and inform Pfeiffer Vacuum.

8.3 Disposal

Products or parts thereof (mechanical and electrical components, operating fluids, etc.) may cause environmental burden.

- Safely dispose of the materials according to the locally applicable regulations.

9 Malfunctions

Please note the following instructions should the pump malfunction:



CAUTION

Hot surface!

Danger of burns if hot parts are touched. The surface temperature of the pump may rise above 105 °C in case of malfunction.

→ Carry out work on the pump only after it has cooled to a safe temperature.

9.1 Rectifying malfunctions

Problem	Possible cause	Remedy
Pump will not start up	No mains voltage or voltage does not correspond to the motor data	Check mains voltage and mains fuse protection; check motor switch
	Missing contact in the remote bridge	Check remote contact and reconnect
	Pump temperature too low	Warm up pump to > 12°C
	Thermal protection switch has responded	Detect and fix cause of overheating; allow pump to cool off if necessary
	Pump system dirty	Clean pump; contact Pfeiffer Vacuum Service if necessary
	Pump system damaged	Clean and overhaul pump; contact Pfeiffer Vacuum Service if necessary
Pump switches off after a while after being started	Mains fuse protection triggered due to overload (e.g. cold start)	Warm up pump
	Exhaust pressure too high	Check opening of exhaust line and exhaust accessories
	Thermal protection switch of motor coil has responded	Allow the pump to cool to a safe temperature, kurzzeitig vom Netz oder Remote-Brücke trennen/schließen
	Thermal protection switch of the fans power supply has responded	Disconnect the pump from the power supply, check the position of the voltage selector switch, check ambient temperature; allow pump to cool off if necessary
Pump does not attain final pressure	Measurement reading is false	Check gauge, check final pressure without installation connected
	Pump or connected accessories are dirty	Clean pump and check components for contamination
	Operating fluid dirty	Operate pump for a longer period with gas ballast valve open or change operating fluid
	Leak in system	Repair leak
	Operating fluid filling level too low	Top off operating fluid
	During standby temperature control mode activ	Switch off temperature control mode
	During standby gas ballast activ	Close gas ballast valve
	Pump damaged	Contact Pfeiffer Vacuum Service
Pumping speed of pump too low	Intake line not well-dimensioned	Keep connections as short as possible and see that cross-sections are sufficiently dimensioned
	Exhaust pressure too high	Check opening of exhaust line and exhaust accessories
Loss of operating fluid	Swivel gasket leaky	Check tightness; replace gasket if necessary
	Operational loss of operating fluid	If necessary, install oil mist filter and oil return unit
Unusual operating noises	Silencer dirty	Clean or replace the silencer
	Damage to the pump system	Clean and overhaul pump; contact Pfeiffer Vacuum Service if necessary
	Motor bearing defective	Replace motor; contact Pfeiffer Vacuum Service if necessary
Pump becomes too hot	Fan is dirty	Clean fan
	Fan is defective	Exchange fan



NOTE

Service work should be carried out by qualified personal only!

Pfeiffer Vacuum is not liable for any damage to the pump resulting from work carried out improperly.

→ Take advantage of our service training programs; additional information at www.pfeiffer-vacuum.com.

→ Please state all the information on the pump rating plate when ordering spare parts.

10 Service

Pfeiffer Vacuum offers first-class service!

- Maintenance/repairs on site by Pfeiffer Vacuum field service
- Maintenance/repairs in a nearby service center or service point
- Fast replacement with exchange products in mint condition
- Advice on the most cost-efficient and quickest solution

Detailed information and addresses at: www.pfeiffer-vacuum.com (Service).

Maintenance and repairs in Pfeiffer Vacuum ServiceCenter

The following steps are necessary to ensure a fast, smooth servicing process:

- Download the forms "Service Request" and "Declaration on Contamination".¹⁾
- Fill out the "Service Request" form and send it by fax or e-mail to your Pfeiffer Vacuum service address.
- Include the confirmation on the service request from Pfeiffer Vacuum with your shipment.
- Fill in the contamination declaration and enclose it in the shipment (required!).
- Dismantle all accessories.
- Drain operating fluid/lubricant.
- Drain cooling medium, if used.
- Send the pump or unit in its original packaging if possible.

Sending of contaminated pumps or devices

No units will be accepted if they are contaminated with micro-biological, explosive or radioactive substances. "Hazardous substances" are substances and compounds in accordance with the hazardous goods directive (current version). If pumps are contaminated or the declaration on contamination is missing, Pfeiffer Vacuum performs decontamination at the shipper's expense.

- Neutralise the pump by flushing it with nitrogen or dry air.
- Close all openings airtight.
- Seal the pump or unit in suitable protective film.
- Return the pump/unit only in a suitable and sturdy transport container and send it in while following applicable transport conditions.

Service orders

All service orders are carried out exclusively according to our repair conditions for vacuum units and components.

¹⁾ Forms under www.pfeiffer-vacuum.com

11 Spare parts

Please also specify model number of the the rating plate when ordering accessories or spare parts.

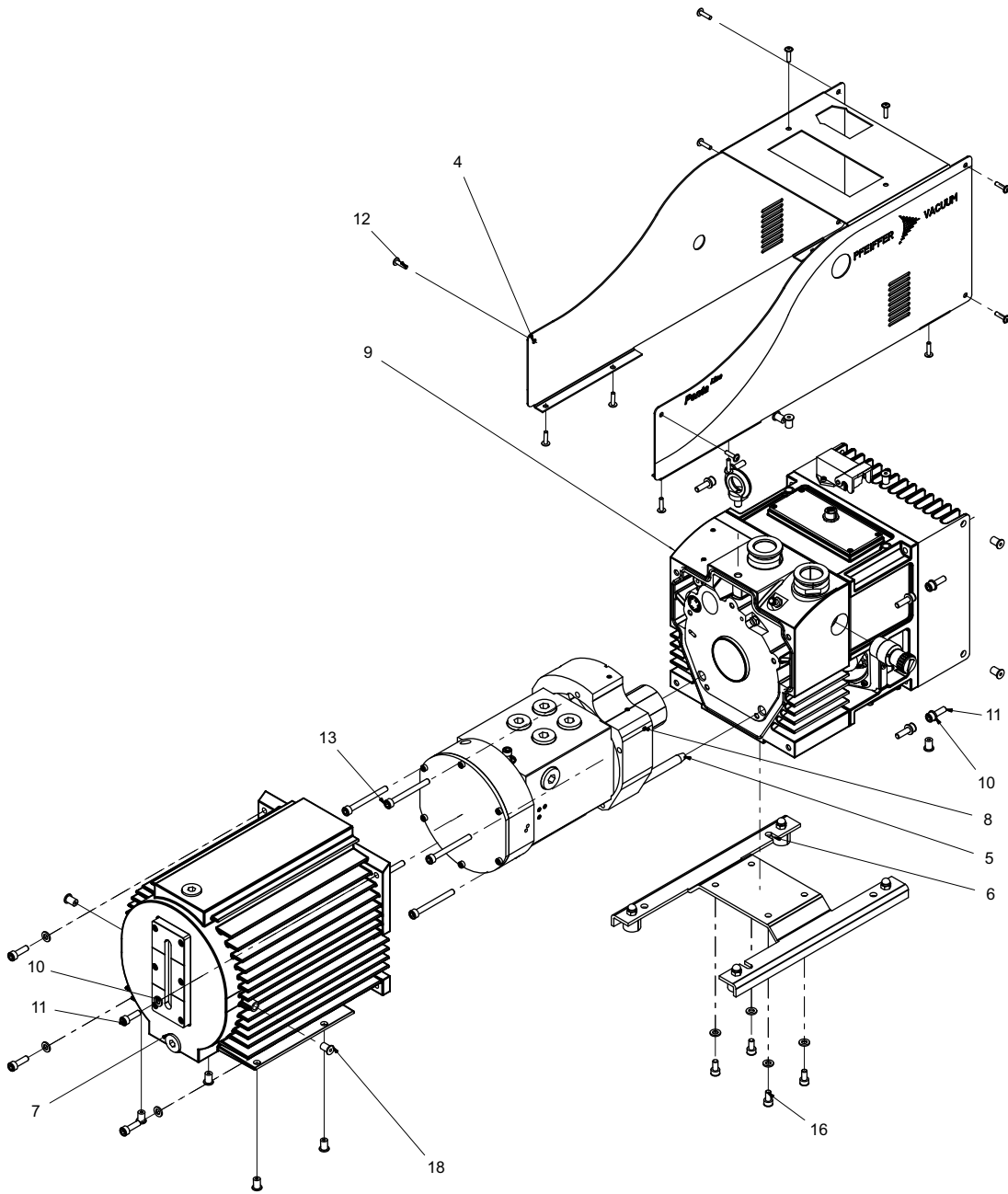

Fig. 13: Exploded view Penta 20/35

12 Accessories

Further detailed accessories are contained in the Pfeiffer Vacuum printed or Online Catalogue.

Designation	Penta 20
STP 025, dust separator, single-stage for minor contamination	PK Z60 206
KAS 25 L, condensate separator for pumping speeds of up to 20 m ³ /h	PK Z10 033
ONF 25 L, oil mist filter for pumping speeds of up to 30 m ³ /h	PK Z40 158
Oil return unit	PK 198 545-T
ZFO 025, zeolite trap	PK Z70 006
URB 025, catalytic trap, 230 V	PT U10 760
URB 025, catalytic trap, 115 V	PT U10 761
Mains cable 230 V AC, with Euro-style safety plug, VII-HAN 3A, 3 m	P4 564 309 HA
Mains supply socket	PM 061 200-T
Customizable release connector	PK 198 548
Operational monitoring - oil pressure switch	PK 196 484-T

Designation	Penta 35
STP 025, dust separator, single-stage for minor contamination	PK Z60 206
KAS 25 L, condensate separator for pumping speeds of up to 20 m ³ /h	PK Z10 033
ONF 25 XL, oil mist filter for pumping speeds of up to 34 m ³ /h	PK Z40 160
Oil return unit	PK 198 545-T
ZFO 025, zeolite trap	PK Z70 006
URB 025, catalytic trap, 230 V	PT U10 760
URB 025, catalytic trap, 115 V	PT U10 761
Mains cable 230 V AC, with Euro-style safety plug, VII-HAN 3A, 3 m	P4 564 309 HA
Mains supply socket	PM 061 200-T
Customizable release connector	PK 198 548
Operational monitoring - oil pressure switch	PK 196 484-T

13 Technical data

Parameter	Penta 20	Penta 35
Flange (in)	DN 25 ISO-KF	DN 25 ISO-KF
Flange (out)	DN 25 ISO-KF	DN 25 ISO-KF
Pumping speed, max.	22 m ³ /h	34 m ³ /h
Ultimate pressure with gas ballast	$\leq 1 \cdot 10^{-2}$ mbar	$\leq 1 \cdot 10^{-2}$ mbar
Ultimate pressure without gas ballast	$\leq 5 \cdot 10^{-3}$ mbar	$\leq 5 \cdot 10^{-3}$ mbar
Rotation speed at stand-by	900 rpm	900 rpm
Rotation speed max.	1800 rpm	1800 rpm
Emission sound pressure level without gas ballast	58 dB (A)	58 dB (A)
Power consumption at 1 mbar	0.41 kW	0.41 kW
Power consumption in stand-by mode	0.225 kW	0.225 kW
Max. power consumption: pump	0.99 kW	1.475 kW
Mains requirement: voltage (selectable)	100-120 V ($\pm 10\%$) 50/60 Hz ; 200-240 V ($\pm 10\%$) 50/60 Hz	100-120 V ($\pm 10\%$) 50/60 Hz ; 200-240 V ($\pm 10\%$) 50/60 Hz
Switch	No	No
Rated current absorption	100-120 V 50/60 Hz, 6.4 A ; 200-240 V 50/60 Hz, 3.1 A	100-120 V 50/60 Hz, 7.5 A ; 200-240 V 50/60 Hz, 3.7 A
Operating fluid filling	1.8 l	1.5 l
Weight	43 kg	45 kg
Temperature: Operating	12-40 °C	12-40 °C
Temperature: Storage	-25-+70 °C	-25-+70 °C
Temperature: Transport	-25-+55 °C	-25-+55 °C

13.1 Dimensions

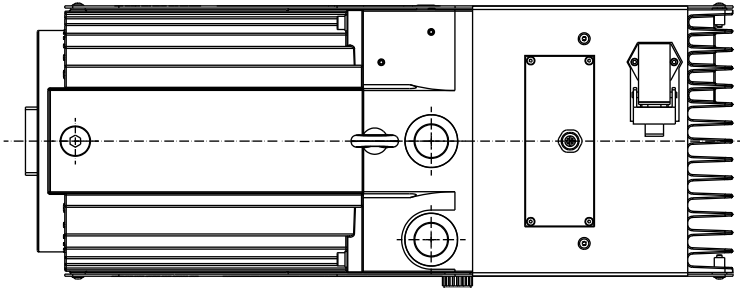
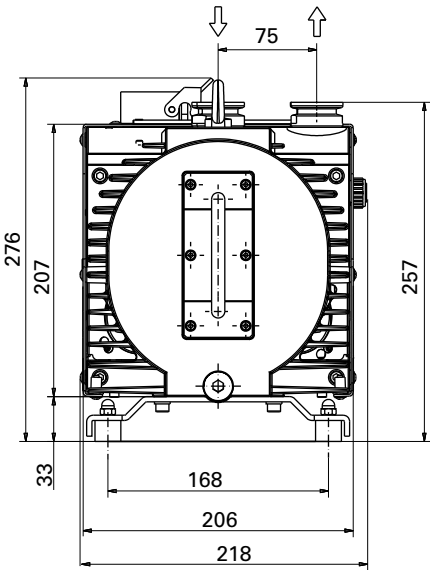
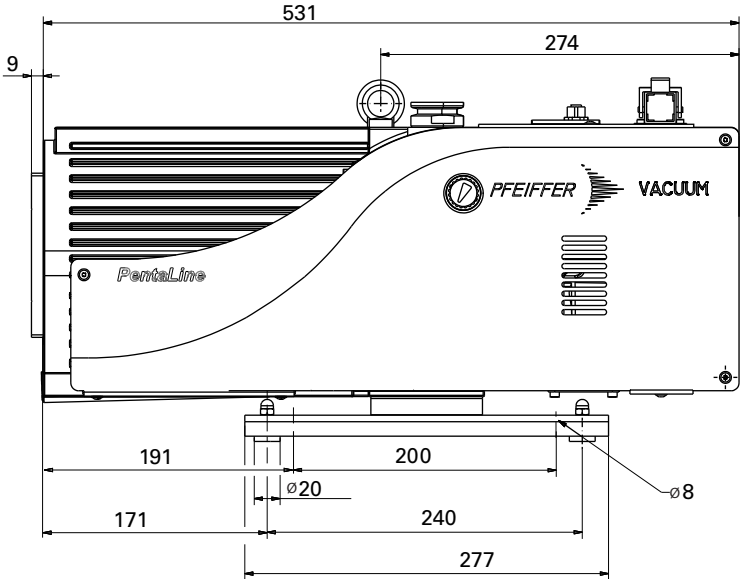



Declaration of conformity

according to the EC directive:

- **Machinery 2006/42/EC (Annex II, no. 1 A)**

We hereby declare that the product cited below satisfies all relevant provisions of EC directive "Machinery" **2006/42/EC**.

In addition, the product cited below satisfies all relevant provisions of EC directive "Electromagnetic Compatibility" **2004/108/EC**.

The agent responsible for compiling the technical documentation is Mr. Sebastian Oberbeck, Pfeiffer Vacuum GmbH, Berliner Straße 43, 35614 Asslar.

PentaLine®

Penta 20/35

Guidelines, harmonised standards and national standards and specifications which have been applied:

DIN EN ISO 12100 : 2011-03	DIN EN 61010 : 2002	DIN EN 61000-6-3 : 2007
DIN EN 1012-2 : 1996	DIN EN 61000-6-1 : 2007	DIN EN 61000-6-4 : 2007
DIN EN ISO 13857 : 2008	DIN EN 61000-6-2 : 2006	

Signatures:

Pfeiffer Vacuum GmbH
Berliner Straße 43
35614 Asslar
Germany

(M.Bender)
Managing Director

(Dr. M. Wiemer)
Managing Director

CE/2011