



## Installation and Operating Instructions



### Rotary Vane Vacuum Pumps R 5 0025, 0040, 0063, 0100 F

Busch LLC  
516 Viking Drive  
Virginia Beach, VA 23452  
Phone: (757) 463-7800  
Fax: (757) 463-7407

## TABLE OF CONTENTS

	Page
Illustration of Major Features	3
GENERAL	4
Identification	4
Operating Principles	4
1.0 INSTALLATION	4
1.1 Unpacking	4
1.2 Location	4
1.3 Power Requirements	4
1.4 Vacuum Connections and Drip Legs	4
1.4.1 Discharge Connection	5
1.5 Oil Filling	5
2.0 OPERATION	5
2.1 Start-up	5
2.2 Gas Ballast	6
2.3 Process Gas	6
2.4 Stopping Pump	6
2.5 Oxygen Service Pumps	6
3.0 ROUTINE MAINTENANCE	7
3.1 Pump Oil	7
3.1.1 Oil Level	7
3.1.2 Oil Type and Quantity	7
3.1.3 Oil and Filter Change	7
3.1.4 Flushing Procedure	8
3.2 Automotive-Type Oil Filter	9
3.3 Exhaust Filter	9
3.4 Vacuum Inlet Filter	9
3.5 Routine Maintenance Schedule	10
3.6 Overhaul Kit/Filter	10
4.0 TROUBLESHOOTING	11
5.0 LIMITED STANDARD WARRANTY	15
Technical Data	16
Parts List	17
Illustration of RA 0025-0040	18
Illustration of RA 0063-0100	19

We reserve the right to change the product at any time without any form of notification. The information in this publication is accurate to the best of our ability at the time of printing. Busch LLC will not be responsible for errors encountered when attempting to perform tasks outlined in this publication which is copyright protected.

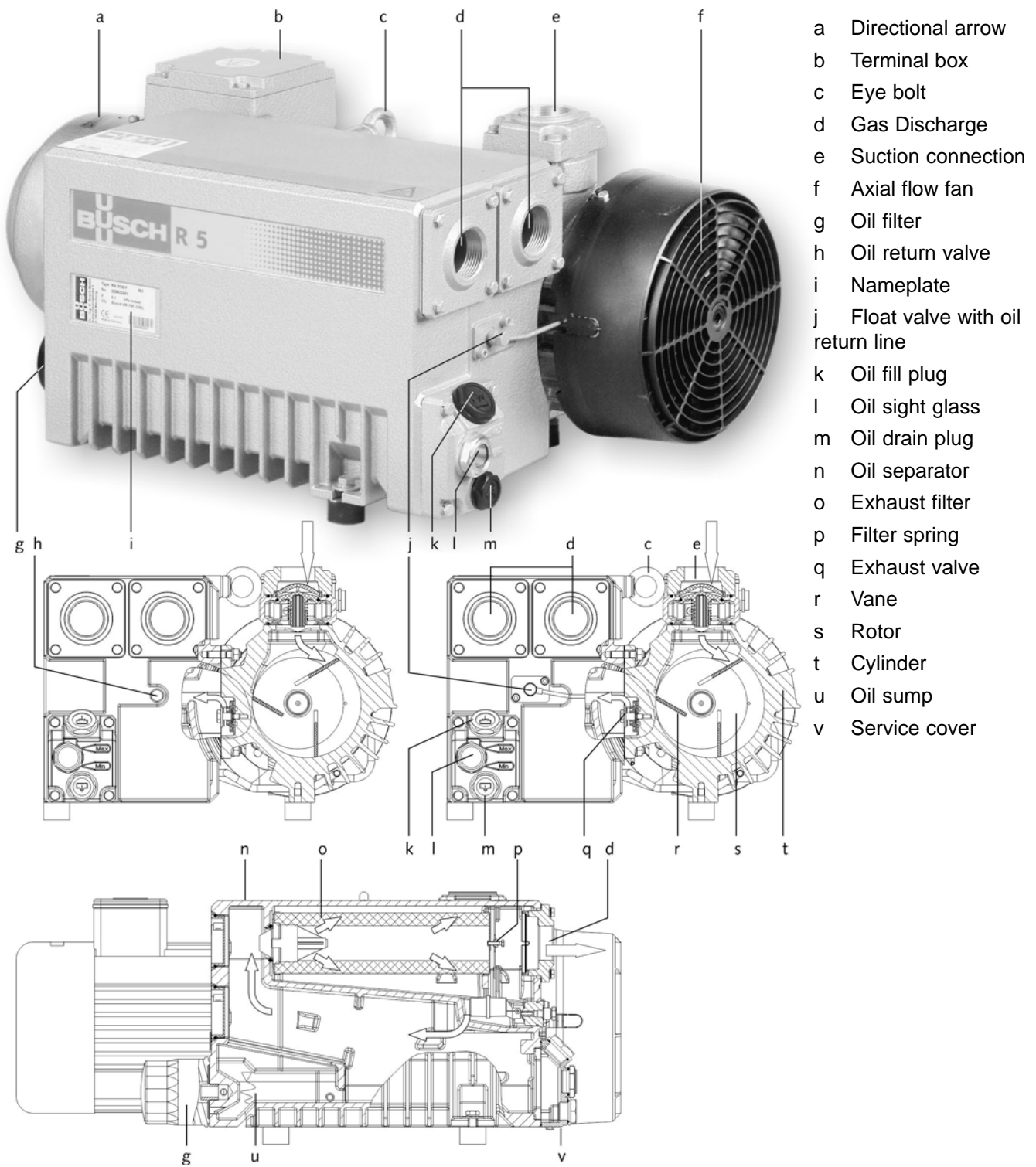

- a Directional arrow
- b Terminal box
- c Eye bolt
- d Gas Discharge
- e Suction connection
- f Axial flow fan
- g Oil filter
- h Oil return valve
- i Nameplate
- j Float valve with oil return line
- k Oil fill plug
- l Oil sight glass
- m Oil drain plug
- n Oil separator
- o Exhaust filter
- p Filter spring
- q Exhaust valve
- r Vane
- s Rotor
- t Cylinder
- u Oil sump
- v Service cover

Figure 1 - Major Features of a Typical R 5 Vacuum Pump

## GENERAL

### Identification

For model identification, see the nameplate mounted on the side of the exhaust box.

This manual is written to cover the 0025, 0040, 0063, 0100 size pumps with an "F" appearing as the seventh character in the model type number. For example, it would appear as follows:

RAXXXX-FXXX-XXXX

When ordering parts, it is helpful to include the identification code and the serial number from the nameplate.

### Operating Principles

Rotation of the pump rotor, which is mounted eccentrically in the pump cylinder, traps entering vapor between rotating vanes. As rotation continues, vapor is compressed and discharged into the exhaust box. Vapors then pass through several stages of internal oil and mist eliminators to remove lubricating oil from the exhaust. The oil that is separated is returned to the inlet via the oil return line. These pumps also include an automotive type spin-on oil filter and a built-in inlet anti-suck-back valve that prevents the pump from rotating backwards.



#### CAUTION

All R 5 series pumps are designed to handle clean air. A limited amount of water vapor in the air stream can be tolerated under certain conditions. Consult Busch, LLC Engineering for operating recommendations in cases where water vapor load is high, otherwise the pump may be damaged.

### 1.0 INSTALLATION

#### 1.1 Unpacking

Inspect the box and pump carefully for any signs of damage incurred during transit.

Remove the nuts from the bottom of the box/crate and pull the pump out of the container, then unscrew the studs from the bottom of the rubber feet.

The inlet port (260) of the pump is covered with a plastic cap to prevent dirt and other foreign material from entering the pump. Do not remove this cover until the pump is ready for connection to your system.

#### 1.2 Location

The pump must be installed in a horizontal position on a level surface so that the pump is evenly supported on its rubber feet. Allow at least 8 inches of air space

between the pump and any walls or other obstructions that may impede the flow of cooling air.

Whenever the pump is transported, be sure to drain the oil prior to shipping to avoid oil accumulating in the pumping chamber and causing vane breakage when restarting the pump.

Do not tip the pump over if it is filled with oil.

Locate the pump for easy access to the oil sight glass in order to inspect and control the oil level properly. Allow clearance at the exhaust flange area to provide service access to the exhaust filter(s) (120).

### 1.3 Power Requirements

The schematic diagram for the electrical connection is located in the junction box or on the nameplate of the pump motor.

The motor must be connected according to the electrical codes governing the installation. The power supply must be routed through a fused switch to protect the motor against electrical or mechanical overloads. The motor starter must be set consistent with the motor current listed on the motor nameplate.

If the pump is supplied with a manual motor starter, it is preset at the factory in accordance with the customer's specification. For other voltage requirements, contact the factory for motor and/or starter information.

Note: See the motor manufacturer's manual for start-up maintenance of the motor.

Correct direction of rotation is marked by an arrow (431) on the motor fan housing and is counterclockwise when looking at the motor from the motor's fan side.



#### CAUTION

After the electrical connection has been made, but before the pump is filled with oil, the rotation of the motor must be checked. Open the inlet port and jog the motor briefly to make sure rotation is correct. If it runs backwards and if it is wired three phase power, reverse any two leads of the three at the power connection.

### 1.4 Vacuum Connections

Remove the plastic protective cap from the inlet port (260) prior to connection of the pump to the system. Vertical connection of the vacuum line can be made directly to the pump inlet.

Use a line size to the vacuum system that is at least as large as that of the pump inlet. Smaller lines will result in lower pumping speeds than the rated values.

Type and size of the inlet connections of the R 5 Series pumps are shown in the TECHNICAL DATA page 17.

If more than one vacuum pump or a receiver tank is connected to a common main line, each pump should have its own manual or automatic operated shut-off valve or positive action check valve. The built-in, anti-suck-back valve should not be used as a shut-off valve for the vacuum system.

 **CAUTION**  
Do not use the anti-suck-back valve as a check or shut-off valve for your vacuum system. Do not depend on the anti-suck-back valve to prevent pump oil from migrating through the inlet into the system when the pump is shut down.

If the gas that is pumped contains dust or other foreign solid particles, a suitable inlet filter (10 micron rating or less) should be connected to the inlet port. Consult the factory for recommendations.



#### 1.4.1 Discharge Connections

Make sure that the line size of the discharge over the entire length is at least as large as the gas discharge connection (155).

If the discharge line exceeds 6.5 feet, it is prudent to use a larger exhaust line to avoid loss of efficiency and overloading of the pump. Discharge back-pressure should not exceed 4 psig. Make sure the discharge line either slopes away from the pump or provide a drip leg with a drain so that liquids can not back into the pump. Check drip leg often to remove any condensation that may have collected.

#### 1.5 Oil Filling

 **WARNING**  
Do not use hydrocarbon oils in pumps used for oxygen service. See Section 2.6 - Oxygen Service Pumps.

  **WARNING**  
Keep the oil fill plug tight as pressure in the exhaust box could cause bodily injury if the plug is blown out. Do not fill/add oil through the inlet port as there is danger of breaking the vanes. Pump must be stopped when adding oil.

The pump is shipped without oil. After level installation, and after correct rotation has been established, fill the pump with the recommended vacuum oil through the oil filling port (88), observing the "MAX" and "MIN" position at the oil sight glass (83).

Use only Busch recommended oils. Other oils may reduce performance and shorten the life of the pump. Busch R500 Series oil should be used to receive the best performance from your vacuum equipment. R500 series oil is high quality vacuum oil that will give longer running time between oil changes, will provide better lubrication at high operating temperatures, and will prolong the life of exhaust filter elements. This oil can be obtained directly from Busch LLC in Virginia Beach, Virginia.

The strict use of Busch oils and parts from the day of purchase can extend the life of the vacuum pump.

For general applications, in ambient temperatures (54-90°F) use R530 in all models covered by this manual. Use R590 or R570 in pumps that are operated in high ambient temperatures (90-104°F) or high operating pressure when the oil carbonizes (turns black) before the change interval.

The TECHNICAL DATA chart on page 17 gives the approximate quantities of oil required for each pump. The oil capacity chart should only be used as a guide, since oil capacity may be slightly lower, depending on whether the pump was filled previously, and whether all components such as oil filter, oil lines, etc., were allowed to completely drain. Use only the sight glass reading for proper level. Never overfill!

For ambient operating temperatures between 41 and 54°F, use Busch R580 synthetic oil. If this does not help (where the pump has difficulty starting due to high oil viscosity), contact the factory in Virginia Beach, Virginia.

Replace the oil fill plug, making sure that the gasket is in place and properly seated and secured. Some pumps are equipped with an exhaust pressure gauge as an integral part of the oil fill plug.

## 2.0 OPERATION

### 2.1 Start-up

Check rotation of the motor as described in Section 1.3.

Fill the pump with oil as described in Section 1.5.

Start the pump and immediately close the inlet. Run the pump for a few minutes before checking the oil level again. With the pump shut off, the oil level should be visible in the oil sight glass, between the "MIN" and "MAX" mark.

 **WARNING**  
During operation the surface of the vacuum pump may reach temperatures in excess of 160°F. Risk of burns!

Note: The oil separated by the exhaust filter element forms droplets on the outside of the exhaust filter that collect at a low point in the upper half of the exhaust box. From there the collected oil is returned to the inlet of the pump through an oil return line. An oil return float valve assembly controls the oil return to the inlet.

On R5 F Series pumps, the collected oil is drawn periodically during operation of the vacuum pump to the inlet flange via the oil return line. The oil return line is connected directly to the area of the exhaust box, downstream of the exhaust filter, which is at atmospheric pressure. As oil accumulates, the float assembly opens, and oil is drawn back into the inlet. The float assembly prevents oil from accumulating and is the reason that the R5 F series pumps can run continuously without having to shut them off for the oil to drain back.

## 2.2 Gas Ballast

Some RA Series pumps are equipped with a gas ballast. If equipped, the gas ballast inlet is located next to the pump inlet port.

The primary function of a gas ballast is to prevent water vapor from condensing in the pump. Condensation causes emulsification of the oil, loss of lubrication, and possible rotor seizure.

## 2.3 Process Gas

The R 5 series pumps are intended for use with air and other dry, non-aggressive, non-toxic, and non-explosive gases.



### **WARNING**

Pumping of gases which are not intended for use with this pump can result in damage to the vacuum pump, risk of injury, or death.

In some applications, when the quantity of the water vapor is moderate, R 5 pumps have been used with good results. On these occasions, the pump must be run until it is up to operating temperature before it is allowed to pump the process gas. The pump must also be operated for a period of time off process and on air (to clear it of process gas) before it is shut down. This operating technique prevents the vapor from condensing in the pump. Before attempting to pump a gas laden with water vapor, contact Busch Engineering for advice.

## 2.4 Stopping Pump

To stop the pump, turn off the power. The pump has a built-in, anti-suck-back valve (257) to prevent the pump from rotating backwards when it is shut off.



### **CAUTION**

The built-in, anti-suck-back valve is not positive action; do not use it as a system check valve.

Install an automatic operated valve (such as a check valve) in front of the pump. If more than one pump is pumping on the same line or if there is sufficient vacuum in the system, oil can be drawn into the piping when the pump is shut down.

All R5 Series pumps are vented internally to atmospheric pressure through venting holes that are next to the exhaust valve assembly.

## 2.5 Oxygen Service Pumps

Oxygen service pumps must be used in oxygen enriched applications that are defined as any application which has a process gas that is above 21% oxygen.

These pumps have been manufactured, solvent washed (to remove organic contaminants) and assembled according to the latest technical standards and safety regulations. If this pump is not installed properly or not used as directed, a dangerous situation or damage might occur. It is mandatory that these operating instructions be read and understood prior to vacuum pump installation and start-up!



### **WARNING**

This pump is filled with a special operating fluid. Do not use any other type of fluid, oil, and/or grease. Use the following oil; use of other oils can introduce organic compounds which may lead to an unsafe situation resulting in personal injury or death.

- Fomblin Y-LVAC 25/6

If you have any questions, please consult the factory for more information



### **WARNING**

For overhaul/repair of oxygen service pumps, Busch LLC strongly recommends that all major repair operations be conducted at the factory. Improper handling of repairs could result in extreme danger to personnel operating the pump.

### 3.0 ROUTINE MAINTENANCE

R 5 Series pumps require very little maintenance; however, to insure optimum pump performance, the following steps are recommended.

#### 3.1 Pump Oil

##### 3.1.1 Oil Level

 **WARNING**  
Do not add oil while the pump is running since hot oil vapor may escape through the oil fill port. Risk of burns.

 **WARNING**  
Insufficient oil quantity in the pump has the potential, under certain conditions, to lead to self-ignition of the remaining oil, causing damage to the pump, injury, or death.

With the pump installed relatively level, make sure that there is sufficient clean oil in the pump. The oil level should be observed on a daily basis and/or after 8 hours of operation and should be replenished if it drops below the 1/4 mark on the oil sight glass (83).

Oil level readings should be done only when the pump is turned off. Oil can be added to the oil fill port if the pump is shut off and the circulating oil has sufficient time to return to the oil sump. The oil might appear to be foamy, which is a normal phenomenon with aerated oil.

Under normal circumstances, it should not be necessary to add or drain oil from the pump between recommended oil changes.

A significant drop in oil level means there is an oil leak or that an exhaust filter is broken. The pump may be smoking excessively. It is normal for the oil to be foamy and light in color in an operating pump. However, if the oil is milky colored, it is an indication that water is present in the oil. If the pump is equipped with a gas ballast, it may be possible to purge water from the oil by operating the pump for an extended period with the inlet connection blanked off and the gas ballast open. If the oil is dark colored, it is contaminated or carbonized and must be changed or evaluated. Depending on the severity of the contamination, a thorough flushing may be needed. Contact the factory for flushing oil (Busch R568) and refer to Section 3.1.4.

##### 3.1.2 Oil Type and Quantity



See Section 1.5 for details on oil type

Pump sizes 0025 and 0040 have an approximate oil capacity of 1 quart. Sizes 0063 and 0100 use approximately 2 quarts.

##### 3.1.3 Oil and Filter Change

Oil life is dependent upon the conditions to which it is exposed. A clean, dry air stream and an oil operating temperature under 210°F are ideal conditions. When using R530 (hydrocarbon oil), it is recommended that oil changes are made every three (3) to four (4) months or 500 to 750 hours of operation, or as necessary if high heat is contaminating the oil. The use of Busch R570 or R590 synthetic oils could extend the operating hours between oil changes under ideal conditions. Oil samples should be taken regularly when exceeding the 500-750 hour recommendation.

##### Excessive Heat

  **WARNING**  
When changing the oil and filters, it may be necessary to flush the pump to remove any build-up of degraded oil from the sumps, oil lines, coolers, etc., to ensure proper oil flow through the pump. Reduced oil flow, especially through cooling coils, can cause mechanical damage or extreme overheating, which could cause the oil vapors to ignite, damaging the pump and causing injury or death.

When the pump is subjected to operating conditions that will cause the oil to be heated above 235°F, the oil will carbonize and become contaminated after a relatively low number of operating hours. The higher the temperature, the quicker the oil becomes contaminated. If the oil temperature is too severe, Busch R570 or R590 synthetic oil should be used to withstand the elevated temperatures. If synthetic oil is used in place of mineral oil, the pump should be flushed with Busch R568 oil before changing oil types.

Auxiliary oil cooling is the most practical approach to a severe heating problem.

##### Contaminated Air Stream

When the air stream contains a solid and/or liquid that can contaminate the oil, it must be changed more often. If the air stream contains a small percentage of contaminants and/or they are slightly aggressive (mild acids, etc.), synthetic oil, such as Busch R570, will resist breakdown better than the standard Busch R530. The solution is to install a filter or knock-out pot to keep the contaminants out of the pump.

Oil change intervals can only be established by experience with the pump operating in the actual conditions (see previous paragraph for some of the conditions). Develop the oil change interval by periodically checking an oil sample removed from the pump. When the oil sample has become dark in color (from solids and carbonized particles) or is milky looking (from water), it is time to discard it. As mentioned before, a thorough flushing may be required.

### 3.1.4 Oil Flushing Procedure

Flushing is needed under certain conditions. Some pumps will be beyond flushing and will need to be overhauled.

To help determine if flushing is needed, observe the condition of the oil as it is drained from the pump. Is it black and tar like or contaminated in any way? Was the pump noisy, overheating, or was the motor overload shutting the pump off? How old is the pump and when was the last time the oil was changed?

If the above conditions exist or you don't know when the last oil change was performed further investigation is needed. Also, when changing from one oil type such as R530 to another type such as R590 or R570 it will be beneficial to flush. Although the oils are compatible, mixing a lesser grade oil such as R530 with a synthetic oil like R570 will reduce the effectiveness of the synthetic oil.

All of the oil will be removed and replaced with the flushing oil (Busch R-568), and eventually that will be replaced by whatever Busch oil is needed for your particular application. Have enough oil and oil filters on hand for a couple of flushes. The following describes the steps in the flushing procedure:

Shut the pump off, drain all the oil from the pump by removing drain plug (95) and remove the gas discharge cover plate(s) (155) from the exhaust box. Remove the exhaust filter spring (125) and the exhaust filter (120) and look at the internal walls of the oil sump. If the walls are discolored but have no build up of any kind one can proceed with the flushing.

If gelled or burnt oil is clinging to the walls, this material must be scraped and removed prior to flushing. Proceed by scraping and cleaning as much of the exhaust box as possible. The more debris that is removed, the more effective the flushing will be. Re-install exhaust filter, filter spring, and discharge cover plate, and proceed with the flushing. At this point one must remember that the oil lines and oil cooler (if equipped) might also be plugged to a point where no amount of flushing will make a difference and a complete overhaul will be the only option. Depending on the severity of the oil contamination flushing may be a last ditch effort.

Drain all of the oil from the pump. The more contaminated oil you remove now the more effective the oil flushing will be.

Remove the oil filter (100) and install a new one. It is recommended that you do not change the exhaust filter or filters until after the flushing to prevent contamination of any new filters.

Fill the exhaust box with the proper amount of flushing oil (Busch R-568).

If possible run the pump with the inlet closed and off of the process. Run the pump for approximately six hours, shut the pump off and drain a small sample of oil into a clear container.

Examine it. If it is clear to amber run the pump for another six hours and examine it again. If after the first six hours it is black drain it and fill again using another new oil filter.

If after the second flushing the oil still remains black the pump may have too much contaminated oil in it to flush out properly. There may be residue remaining in the lines and cooler that will not flush out. An overhaul will be necessary.

If after the second six hour period the oil still remains clear to amber in color drain it, change the oil filter and fill with the regular oil. At this point also change the exhaust filters.

Run the pump with a fresh charge of the oil to be used in your application (not R-568), and monitor the operating conditions closely. Check for noise, overheating and oil condition until a regular oil change schedule can be established.

Do not let the oil turn black. Change it before it fails. If the oil is kept in good condition the pump will last for years. If the oil starts to turn black do not hesitate to flush again. Keeping on top of the oil changes will prevent costly overhauls.

If you are just switching from one type of oil to another a single six hour flush is all that is necessary (follow the above instructions). Remember to change to a new exhaust filter or filters (120) after the flushing and not before.

### 3.2 Automotive-Type Oil Filter

These R5 F Series pumps are equipped with an automotive-type oil filter (100). When replacing the automotive-type oil filter, use only a genuine Busch filter.

Note: Make sure to tighten the Busch oil filter securely against the aluminum sealing surface so that leaks will not occur.



### 3.3 Exhaust Filter



#### **WARNING**

If the gas entering this pump is a health hazard, use rubber gloves and all necessary personal protection equipment when performing the exhaust filter replacement operation.

Every nine (9) to twelve (12) months, or as necessary, replace the exhaust filter elements. The service life of the exhaust filters varies widely with pump application. It is only necessary to change the filters when the elements become clogged with foreign material or burned oil. Indications of clogged filters are smoke and oil mist coming from the pump exhaust, higher than normal motor current, or oil leaking from the gas ballast (if equipped).

A pressure gauge is supplied with your R 5 vacuum pump as part of the oil fill plug (88). This gauge has a green field and a red field. Pressure within the green field would indicate normal pressure. Pressure in the red field (for a continuous period of time) requires an immediate change of the exhaust filter(s) (120).

In order to replace the filter, remove the screws (146) retaining the exhaust port cover plate. Pull the cover plate assembly (155) off the exhaust box; set it aside. Use a slotted head screw driver to loosen the exhaust filter retaining spring (125), then rotate and remove the spring. Pull the filter cartridge (120) out of the exhaust box.



#### **WARNING**

Wear safety glasses when installing or removing the spring retainers. The retainers can, if not secured correctly, slip off and fly out of the exhaust box, causing eye injury.

To field test an exhaust filter element, remove it from the pump, allow it to cool, clean the sealing end (or O-ring end), and use compressed air to blow through the element. Apply approximately 3 to 6 psi (maximum allowable operating pressure across the filter).



#### **WARNING**

Do not inhale through the filter or allow your mouth to come in direct contact with the filter.

Use a clean shop rag to seal off the connection between the air hose and the filter. If you can blow through it, the element is not plugged. If plugged, discard it and install a new one. The filter cannot be cleaned successfully. Visually inspect the filter element for cracks.

Use a clean shop rag to seal off the connection between the air hose and the filter. If you can blow through it, the element is not plugged. If plugged, discard it and install a new one. The filter cannot be cleaned successfully. Visually inspect the filter element for cracks.

Reinstall the filter elements. Make sure the open end of the element is properly seated down in its recess in the exhaust box with the O-ring correctly positioned. Retain the filter with the spring clip (125), tighten the tension screw until the filter is secure. Place the exhaust port gasket (141) and cover (155) in position on the exhaust box and retain with the cap screws (146).

### 3.4 Vacuum Inlet Filter

If the pump is equipped with a special vacuum inlet filter in applications where powder, dust or grit is present, the filter cartridge should be cleaned on a weekly basis, or as required, depending on the amount of foreign particles to which the pump is exposed.

### 3.5 Routine Maintenance Schedule

See the motor manufacturer's manual for the periodic motor maintenance.

Daily:

- Visually check oil level and color (see 3.1.1).

Weekly:

- Check the vacuum pump for oil leaks.

Monthly:

- Test exhaust filter(s) for proper function.
- Remove the suction line from the pump inlet so that the pump is pulling on atmospheric air. Check that the reading on the filter pressure gauge is in the green field. Reconnect the suction line.
- Check inlet filter (if installed). Clean or replace as necessary.

Every 6 months:

- Make sure that the housing is free from dust and dirt, clean if necessary.
- With the pump shut off and secured against inadvertent start-up, clean the fans, ventilation grills, and cooling fins.

Every year:

- Replace exhaust filters (120)
- Replace inlet air filter (if installed)
- Check the inlet screen (261), clean if necessary
- Clean gas ballast filter (440) (if installed)

Every 500 - 2000 Operating Hours

- Change the oil and the oil filter (100) (see 3.1.3)
- Check the float valve (200)

As necessary: Check and/or clean the standard inlet screen. If the optional inlet filter is used, replace the filter material as practice determines.

The oil cooling coils (only on model 0100) and any motor or pump grill covers on all models should be inspected regularly for debris. Clean as necessary. Soiling prevents cool air intake or movement and may lead to overheating of the pump.

Drain drip legs on exhaust piping.

### 3.6 Overhaul Kit/Filter

An overhaul kit containing a set of gaskets and O-rings, vanes, bearings and bearing sleeves, shaft seals and taper pins, is available from the factory.

Also, a filter kit containing oil drain plug, gaskets, automotive-type oil filter, exhaust filter, and synthetic baffle strainer (where applicable), is available from the factory.

When ordering, please be ready to provide all of the information from the nameplate.

#### 4.0 TROUBLESHOOTING

Problem	Possible Cause	Remedy
<p>Pump does not reach “blank-off” pressure, or the pump takes too long to evacuate the system</p>	Oil is contaminated	Shut off pump, drain oil and replace automotive-type oil filter (where applicable) when pump is cool. Flush and fill pump with new oil and take new blank off measurement after operating temperature is reached.
	Leakage in suction line	Check the piping for leaks.
	Wire mesh inlet screen (261) plugged	Clean wire mesh inlet screen. Install inlet filter if problem repeats frequently.
	No oil or not enough oil in oil reservoir	Shut off pump and add necessary oil.
	Automotive-type oil filter (100) is dirty or clogged	Replace automotive-type oil filter, exchange oil, if necessary, and refill with fresh oil.
	Inlet valve plate (257) stuck in closed or partially open position due to contamination	Disassemble inlet valve and screen. Clean as required.
	Oil tubing plugged and/or leaking	Replace, clean and/or retighten the oil fittings. Replace only with same size tubing.
	Shaft seal (35) leaking	Replace the shaft seal.
	Exhaust valve (159) is not properly seated or it is partially stuck open	Properly seat or loosen exhaust valve.
	Vaness (22) are blocked in the rotor (14) or they are damaged	Free vanes or replace with new ones.
	Radial clearance between the rotor (22) and cylinder (1) is no longer adequate.	Re-set the radial clearance.
	Internal parts worn or damaged	Replace worn or damaged parts.
Oil float valve (200) broken or stuck open	Check the cleanliness and function of the oil float valve. Blow out with compressed air if necessary.	
Gas ballast (440) open	Close gas ballast.	

Problem	Possible Cause	Remedy
Pump will not start	The motor does not have the correct supply voltage	Provide the correct supply voltage.
	The motor starter overload settings are too low or trip level is too low	Check overload settings in motor starter for size and setting according to motor nameplate data.
	A fuse is blown	Check the fuses, replace if necessary
	Connection wiring is too small or runs are too long causing too great a voltage drop	Use proper wiring size.
	Pump or motor is blocked	Remove fan cover (340) and try to turn pump and motor by hand. If frozen, remove motor from pump and check motor and pump separately. If pump is frozen, contact Busch LLC Service Department in Virginia Beach, Virginia for suggestions.
	Electric motor (400) has failed and seized	Check and replace motor bearings or replace motor if windings have burned up.
Pump starts, but labors and draws a very high current	Oil too heavy (viscosity too high) or ambient temperature below 5 degrees C (41°F)	Change to R580 vacuum oil if very cold, or warm up oil before starting the pump.
	Pump runs in the wrong direction	Check for correct rotation which is counterclockwise when looking at the motor from the motor's fan side.
	Pump is overfilled with oil or wrong kind of oil is used	Correct the oil level and quality per Section 1.5 and use recommended oil
	Exhaust filters (120) in exhaust chamber are clogged and appear burned black with pump oil	Replace exhaust filters, maintain proper oil condition, oil level, and use only Busch recommended vacuum oil
	The exhaust filter (120) is clogged due to process material	Contact the factory in Virginia Beach, Virginia for recommendations.
	Loose connection in motor terminal box (432); not all motor coils are properly connected. Motor operates on two phases only	Check motor wiring diagram for proper hookup, especially on motors with six internal motor windings, tighten and/or replace loose connections.
	Foreign particle in pump; vanes (22) broken; bearing (30) seizing	Remove foreign parts, and replace vanes and bearings.

Problem	Possible Cause	Remedy
Pump discharges smoke at the exhaust port or expels oil droplets from the exhaust	Exhaust filter (120) is not properly seated with O-ring or filter material is cracked	Check condition and check for proper seating of exhaust filters. Replace if necessary. Also, check filter spring clips for tightness.
Note: An oil filling plug with pressure gauge (88) is provided on all R5 F Series pumps, so that the pressure in front of the exhaust filters can be monitored. The green field indicates that the filters are still effective. Back pressure that causes a continuous reading in the red field requires immediate change of exhaust filters.	Exhaust filter (120) is clogged with foreign particles	Replace exhaust filter.
	The oil return valve is stuck closed. Proper function allows valve to open when oil level begins to build and closes when oil is drained.	Free or replace the oil return check valve.
	 <b>WARNING</b> Do not apply pressure or vacuum by mouth	
	Oil return line (195) is clogged	Free clogged line or replace. Check that oil is being drawn out of the exhaust filter area while the vacuum pump is operating.
Pump runs very noisily	Coupling insert (312) worn	Replace coupling insert in motor/pump coupling.
	Bearing (30) noise	Replace bearings.
	Vaness (22) stuck	Replace vanes, Use recommended Busch oil. Change oil more frequently.
The pump runs very hot. See Technical Data for typical oil sump temperature.	Not enough air ventilation to the pump	Clean motor and pump air grills. Do not install the pump in an enclosed cabinet unless a sufficient amount of cool air is supplied to the pump. On pumps with oil cooling coils, clean outside fin assembly. Bring ambient air temperature down.
Note: The oil temperature with a closed inlet should be approximately 185-225°F depending on pump type. At 24 in. Hg, the oil in the pump can go above 225°F. These values are taken at an ambient temperature of 68°F. The maximum recommended ambient operating temperature for an R 5 is 104°F on a continuous basis. When it is necessary to operate a pump in ambient temperatures above this limit, careful oil monitoring and/or optional water cooling is necessary. Contact the factory for details.	Automotive-type oil filter (100) clogged and pump does not receive enough oil	Change automotive oil filter.
	Not enough oil in oil reservoir, or badly burned oil is used for pump lubrication	Drain and refill only with Busch recommended oil. Increase oil change intervals.

Problem	Possible Cause	Remedy
Pump is seized	Pump operated without oil and vanes (22) are broken	Disassemble and exchange vanes; contact Busch LLC Service Department in Virginia Beach, Virginia for suggestions.
	Pump was operated for an extended period of time in the wrong rotation	Inspect vanes and replace; contact Busch LLC Service Department in Virginia Beach, Virginia for suggestions .
	Liquid carryover into the pump cylinder broke vanes while pump was running, or oil broke vanes on start-up	<p>(a) Install condensate trap on the inlet of the pump</p> <p>(b) Pump was overfilled with oil in oil reservoir. Follow oil filling procedure (see Section 1.5) and do not overfill</p> <p>(c) Built-in, anti-suck-back valve leaking while pump was shut down and vacuum was left in manifold. Clean valve seat and check that anti-suck-back valve holds vacuum on inlet when pump is shut down</p> <p>d) Two pumps or a receiver is on the same main line. Install a manual or automatic operated valve in front of each pump</p>
Automotive-type oil filter (100) does not get warm within two to five minutes when cold pump is started	Automotive-type oil filter is clogged	Replace automotive-type filter per Section 3.2 and exchange oil per Section 1.5.
	Wrong automotive-type filter is used and/or oil lines and oil coolers leading to pump are clogged	Use only automotive filter as listed in Section 3.2 and blow lines free. Flush oil cooler.

## 5.0 LIMITED STANDARD WARRANTY

Busch LLC warrants that all products furnished by it are free from defects in material and workmanship at the time of shipment for a period as indicated: All Busch vacuum pumps, unless otherwise stated, are covered by an 18-month warranty from the date of shipment, or 12 months from the date of installation, whichever occurs first; Reconditioned vacuum pumps are covered by a 12-month warranty from the date of shipment; Other Busch parts and components carry a 90-day warranty from the date of shipment.

In the case of components purchased by Busch LLC, such as starters, controls, mechanical seals, motors, couplings, etc., the warranty of that manufacturer will be extended to the purchaser in lieu of any warranty by Busch LLC. The replacement of wear items including, but not limited to, seals, bearings, couplings, oil drain plugs, oil fill plugs etc., made in connection with normal service, are not covered by this Warranty.

The Limited Standard Warranty is valid only when the product has been properly installed, used in a normal manner, and serviced according to the operating manual. This Warranty shall not extend to products that have been misused, neglected, altered, or repaired without factory authorization during the warranty period. We highly recommend the use of Busch oils and parts to achieve documented performance and efficient operation. The use of oils or parts other than Busch could limit the life expectancy of the product and will void any warranties. Operating conditions beyond our control such as improper voltage, excessive ambient temperatures, or other conditions that would affect the performance or life of the product will also cause the Warranty to become void.

Permission to return parts for warranty repair must be obtained, and all returns must be prepaid to the factory. If, after examination, the product or part is found to be defective, it will be repaired or replaced on a no-charge basis and returned, EX WORKS ORIGIN (EXW Origin); Incoterms 2010. If it is determined that the Warranty has not been breached by Busch LLC, then the usual charges for repair or replacement will be made, EX WORKS ORIGIN (EXW Origin); Incoterms 2010. Parts or products that are obsolete or those made to special order are not returnable.

This Limited Standard Warranty applies only to the above and is for the period set forth. Busch LLC's maximum liability shall not, in any case, exceed the contract price for the product, part, or component claimed to be defective; and Busch LLC assumes no liability for any special, indirect, or consequential damages arising from defective equipment.

SELLER DISCLAIMS ALL OTHER EXPRESS OR IMPLIED WARRANTIES, INCLUDING ALL IMPLIED WARRANTIES OF MERCHANTABILITY AND FITNESS OR FITNESS FOR A PARTICULAR PURPOSE. IN NO EVENT WILL SELLER BE LIABLE FOR ANY INCIDENTAL, PUNITIVE, SPECIAL OR CONSEQUENTIAL DAMAGES ARISING DIRECTLY OR INDIRECTLY FROM THE OPERATION OR USE OF THE PRODUCT.

<b>Technical Data</b>				
<b>Model</b>	<b>0025</b>	<b>0040</b>	<b>0063</b>	<b>0100</b>
Nominal pumping speed (ACFM)	18	28	45	71
Ultimate pressure (torr)	0.075	0.075	0.075	0.075
Nominal motor rating (HP)	1.5	2.0	3.0	5.0
Sound level (dBA) EN ISO 2151	63	66	66	68
Oil capacity (qts)	1.0	1.0	2.0	2.0
Approximate weight (lbs)	106	120	172	198
Inlet size - NPT (inch)	1 1/4	1 1/4	1 1/4	1 1/4



Parts List for R 5 0025-0100 F

Ref Description

001 Cylinder  
 015 Rotor  
 018 Bearing Sleeve  
 022 Vane  
 024 Assembly, endplate, motor side  
 025 Endplate, motor side  
 026 Endplate, fan side  
 027 Assembly, endplate, fan side  
 030 Bearing  
 035 Shaft seal  
 042 Shaft seal retaining plate  
 043 Screw  
 046 O-ring  
 047 Plug, gas ballast  
 050 O-ring  
 053 Screw  
 057 Screw  
 060 Taper pin  
 065 Shaft key  
 066 Shaft key  
 075 Exhaust box  
 083 Oil sight glass  
 084 Sight glass gasket  
 088 Oil fill plug  
 089 Oil fill plug gasket  
 090 Fill plug gauge assembly  
 090.1 Pressure gauge green/red fld  
 095 Oil drain plug  
 096 O-ring  
 099 Nipple  
 100 Oil filter  
 105 Drum plug  
 106 O-ring  
 120 Exhaust filter  
 125 Exhaust filter spring  
 136 Service block gasket  
 138 Screw  
 139 Service block  
 141 Exhaust cover gasket  
 144 Retaining ring  
 145 Exhaust cover plate  
 146 Screw  
 151 Exhaust screen, coarse  
 152 Exhaust screen, fine  
 155 Assembly, exhaust cover  
 159 Exhaust valve assembly  
 185 Gasket, cylinder/exhaust box  
 186 Stud  
 191 Nut  
 195 Oil return line  
 200 Oil return float valve assembly  
 210 Oil feed lines  
 219 Hydraulic fitting, straight  
 220 Hydraulic fitting, straight  
 221 Hydraulic fitting, banjo  
 222 Hydraulic fitting, straight

Ref Description

223 Hydraulic fitting, elbow  
 227 Hollow screw  
 228 Hollow screw  
 230 Oil tubing, coil  
 231 Oil tubing, fan side  
 232 Oil tubing, motor side  
 233 Hydraulic fitting, banjo  
 240 Cooling coil with fittings  
 250 Lower inlet flange  
 251 Valve disk  
 252 Valve guide  
 253 O-ring  
 254 Valve spring  
 255 O-ring  
 257 Assembly, anti-suckback valve  
 260 Upper inlet flange  
 261 Conical inlet screen  
 265 Screw  
 291 Hydraulic fitting, straight  
 295 Oil return line kit  
 300 Motor mounting bracket  
 301 Screw  
 310 Coupling, complete  
 311 Coupling half, pump side  
 312 Coupling insert  
 313 Coupling half, motor side  
 319 Spacer  
 321 Fan  
 326 Retaining ring  
 340 Fan guard  
 341 Screw, self tapping  
 345 Fan cover screen  
 391 Eyebolt  
 400 Motor  
 401 Screw  
 411 Screw  
 412 Motor foot bracket  
 415 Screw  
 416 Stud  
 421 Foot, rubber  
 422 Foot, rubber w/ stud  
 423 Lock washer  
 424 Nut  
 425 Flat washer  
 431 Label, directional arrow  
 436 Label, Busch  
 440 Gas ballast assembly

Note: This parts list includes parts for all the pumps covered by this manual. Your specific model might not necessarily have all the parts indicated in this list. Refer to the illustration for your specific model pump when comparing part numbers or consult the factory.

Illustration of RA 0025-0040

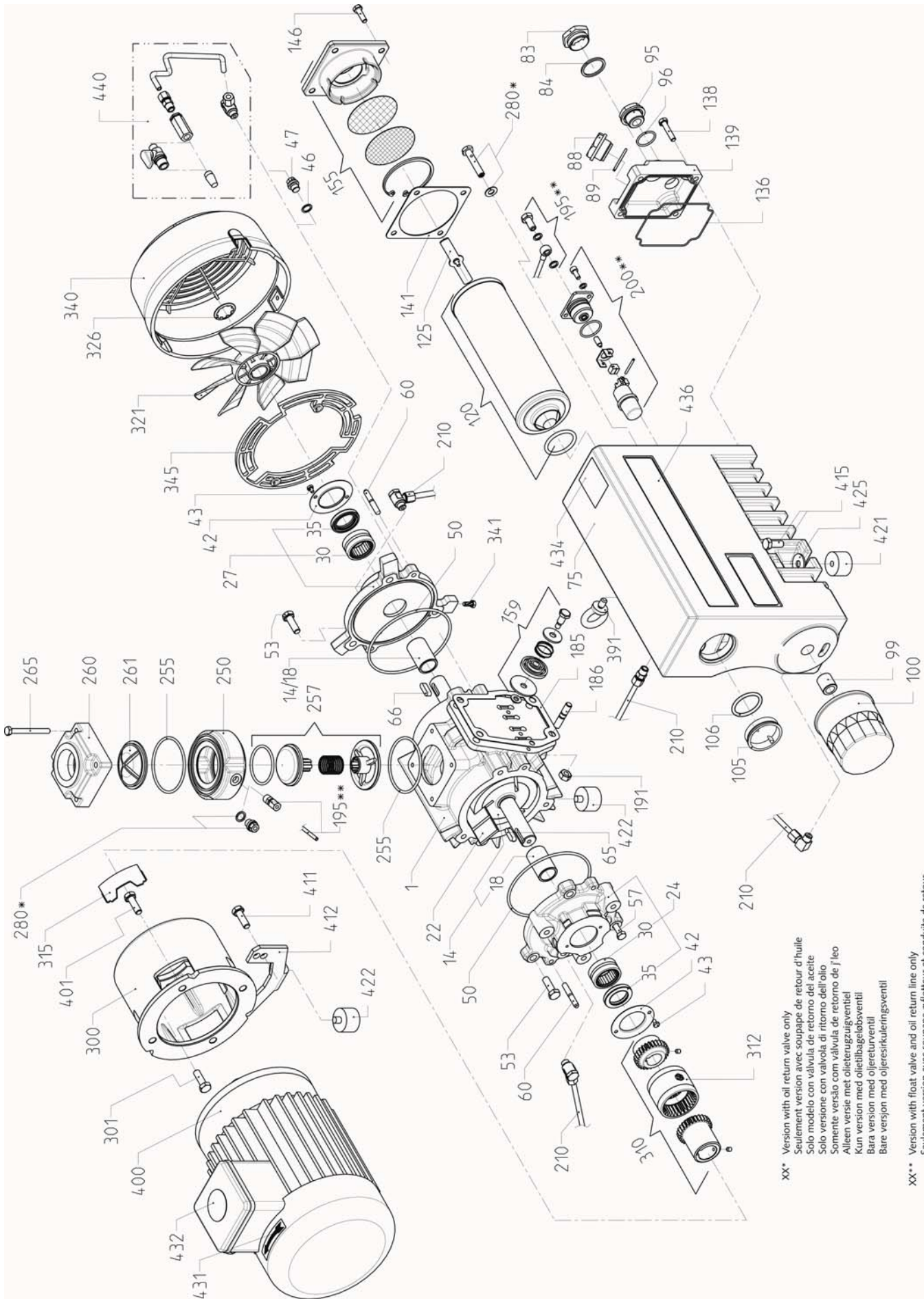

**XX\*** Version with oil return valve only  
 Seulement version avec soupape de retour d'huile  
 Solo modelo con válvula de retorno del aceite  
 Solo versione con valvola di ritorno dell'olio  
 Somente versio con válvula de retorno de f'leo  
 Alleen versie met olieterugzuigventiel  
 Kun version med oljereturventil  
 Bare versjon med oljereturventil  
 Bare versjon med oljereturventil

**XX\*\*** Version with float valve and oil return line only  
 Seulement version avec soupape flotteur et conduite de retour  
 Solo modelo con válvula de flotador y línea de retorno de aceite  
 Solo versione con valvola a galleggiante e tubazione di ritorno dell'olio  
 Somente versio com bj ja e linha de retorno de f'leo  
 Alleen versie met vlotterklep en olieterugleiding  
 Kun version med svømmerventil og oliefløabelsventil  
 Bare version med flottventil och oljereturledning  
 Bare versjon med flottventil og oljereturledning

Illustration of RA 0063-0100

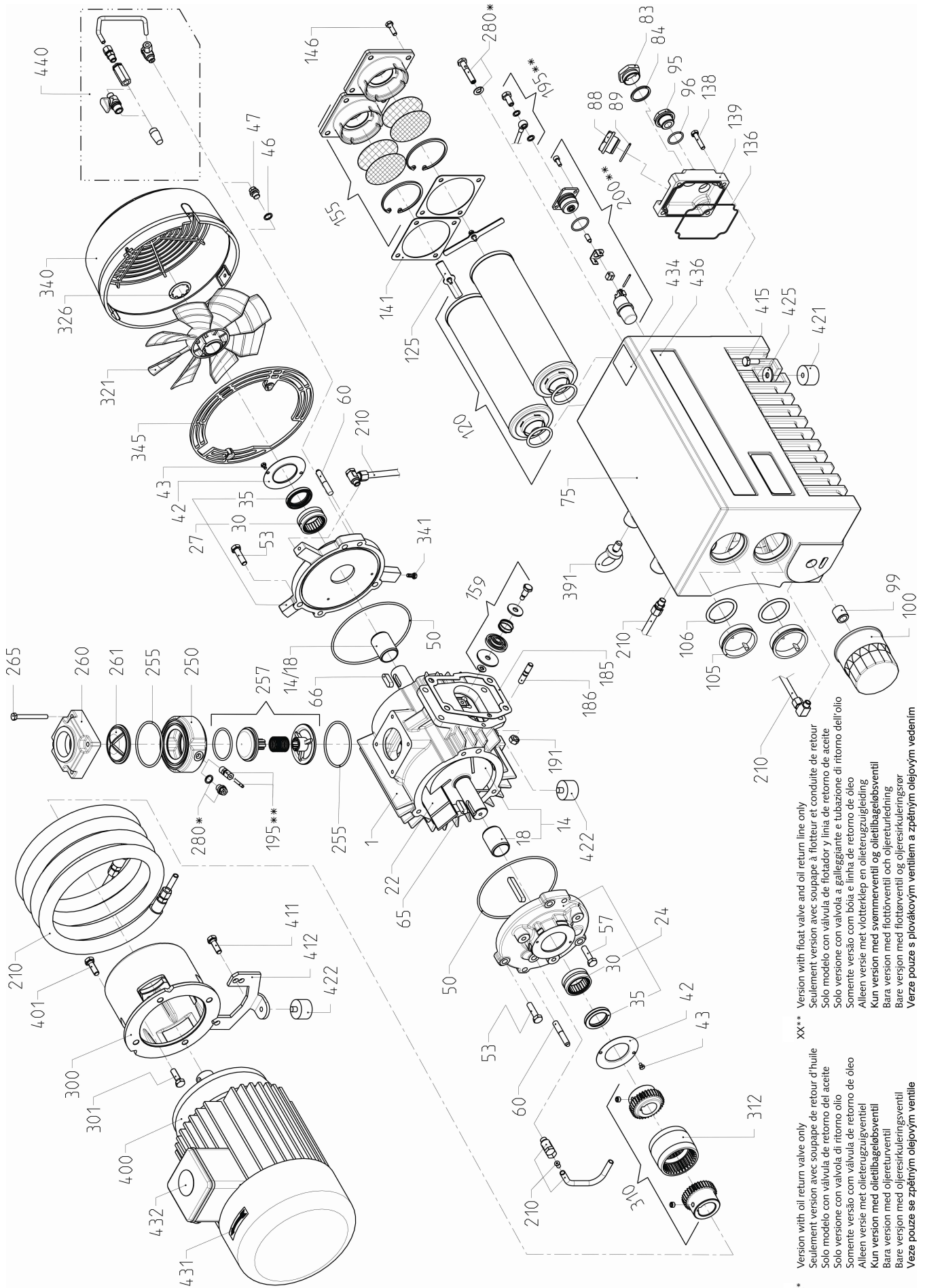

**XX\*** Version with oil return valve only  
 Seulement version avec soupape de retour d'huile  
 Solo modelo con válvula de retorno del aceite  
 Solo versione con valvola di ritorno olio  
 Somente versão com válvula de retorno de óleo  
 Alleen versie met olieterugzuigleiding  
 Kun version med oljetilbageledning  
 Bara version med oljereturledning  
 Bara version med oljeresiktning  
 Verze pouze se zpětným olejovým ventil

**XX\*\*** Version with float valve and oil return line only  
 Seulement version avec soupape à flotteur et conduite de retour  
 Solo modelo con válvula de flotador y línea de retorno de aceite  
 Solo versione con valvola a galleggiante e tubazione di ritorno dell'olio  
 Somente versão com bóia e linha de retorno de óleo  
 Alleen versie met vlotter/leeg en olieterugzuigleiding  
 Kun version med svømmerventil og olietilbageledning  
 Bara version med flottörentill och oljereturledning  
 Bara version med flottörentill och oljeresiktning  
 Verze pouze s plovákovým ventilem a zpětným olejovým vedením

## Argentina

Busch Argentina S.R.L.  
Santo Domingo 3076  
C1293AGN-Capital Federal  
Buenos Aires  
Phone: +54 11 4302 8183  
Fax: +54 11 4301 0896  
e-mail: info@busch-vacuum.com.ar

## Australia

Busch Australia Pty. Ltd.  
30 Lakeside Drive  
Broadmeadows, Vic. 3047  
Phone: +61 3 93 55 06 00  
Fax: +61 3 93 55 06 99  
e-mail: sales@busch.com.au

## Austria

Busch Austria GmbH  
Industriepark Nord  
2100 Korneuburg  
Phone: +43 2262 / 756 65-0  
Fax: +43 2262 / 756 65-20  
e-mail: busch@busch.at

## Belgium

Busch N.V.  
Kruinstraat 7  
9160 Lokeren  
Phone: +32 9 / 348 47 22  
Fax: +32 9 / 348 65 35  
e-mail: info@busch.be

## Brazil

Busch do Brasil Ltda.  
Estrada Municipal Santo Gastaldi, 160  
13240-000 Jarinu-SP  
Phone: +55 11 4016 1400  
Fax: +55 11 4016 5399  
e-mail: vendas@buschdobrasil.com.br

## Canada

Busch Vacuum Technics Inc.  
1740, Lionel Bertrand  
Boisbriand, Québec J7H 1N7  
Phone: +1 450 435 6899  
Fax: +1 450 430 5132  
e-mail: info@busch.ca

## Chile

Busch Chile S. A.  
Calle El Roble N° 375-G  
Lampa - Santiago  
Phone: +56 2 3765136  
Fax: +56 2 7387092  
e-mail: info@busch.cl

## China

Busch Vacuum (Shanghai) Co., Ltd  
No.5, Lane 195 Xipu Road  
Songjiang Industrial Estate East New Zone  
Shanghai 201611 PRC  
Phone: +86 (0)21 67600800  
Fax: +86 (0)21 67600700  
e-mail: busch@busch-china.com

## Czech Republic

Busch Vakuum s.r.o.  
Jugoslávská 868/4a  
613 00 Brno  
Phone: +420 530 504 410  
Fax: +420 530 504 420  
e-mail: info@buschpumps.cz

## Denmark

Busch Vakuumteknik A/S  
Parallelvej 11  
8680 Ry  
Phone: +45 87 88 07 77  
Fax: +45 87 88 07 88  
e-mail: info@busch.dk

## Finland

Busch Vakuumteknik Oy  
Sinkellontie 4  
01300 Vantaa  
Phone: +358 9 774 60 60  
Fax: +358 9 774 60 666  
e-mail: info@busch.fi

## France

Busch France S.A.S.  
16, Rue du Bois Chaland  
91090 Lisses  
Phone: +33 16989 8989  
Fax: +33 16989 8958  
e-mail: busch@busch.fr

## Germany

Dr.-Ing. K. Busch GmbH  
Schauinslandstrasse 1  
79689 Maulburg  
Phone: +49 7622 681-0  
Fax: +49 7622 6 5484  
e-mail: info@busch.de

## Hungary

Busch Vacuum Kft.  
Gyári út 23.  
2310 Szigetszentmiklós  
Phone: +36 24 887 308  
Fax: +36 24 887 309  
e-mail: busch@buschvacuum.hu

## India

Busch Vacuum India Pvt Ltd.  
103, Sector 5  
IMT Manesar  
Gurgaon  
Haryana - 122 050  
Phone: +91 124 4050091  
Fax: +91 124 2292103  
e-mail: sales@buschindia.com

## Ireland

Busch Ireland Ltd.  
A10-11 Howth Junction Business Centre  
Kilbarrack, Dublin 5  
Phone: +353 1 832 1466  
Fax: +353 1 832 1470  
e-mail: sales@busch.ie

## Israel

Busch Israel Ltd.  
1 Mevo Sivan Street  
Qiryat Gat 82022, Israel  
Phone: +972 (0)8 6810485  
Fax: +972 (0)8 6810486  
e-mail: service\_sales@busch.co.il

## Italy

Busch Italia S.r.l.  
Via Ettore Majorana, 16  
20054 Nova Milanese  
Phone: +39 0362 370 91  
Fax: +39 0362 370 999  
e-mail: info@busch.it

## Japan

Nippon Busch K.K.  
1-23-33, Megumigaoka  
Hiratsuka City, Kanagawa  
Japan 259-1220  
Phone: +81 463-50-4000  
Fax: +81 463-50-4004  
e-mail: info@busch.co.jp

## Korea

Busch SVG Korea, Inc  
189-51, Soicheon-ro, Majang-myun,  
Icheon-si, Gyunggi-do, 467-813,  
Republic of Korea  
Phone: +82 31 645 2700  
Fax: +82 31 631 2898  
e-mail: busch@buschsvg.co.kr

## Malaysia

Busch Malaysia Sdn Bhd.  
4&6, Jalan Taboh 33/22, Seksyen 33  
Shah Alam Technology Park  
40400 Shah Alam  
Selangor Darul Ehsan  
Phone: +60 3 5122 2128  
Fax: +60 3 5122 2108  
e-mail: busch@busch.com.my

## Mexico

Busch Vacuum Mexico S. de R.L. de C.V.  
Tlaquepaque 4865, Los Altos  
Monterrey, Nuevo Leon  
Mexico 64370  
Phone: +52 81 8311-1385  
Fax: +52 81 8311-1386  
e-mail: info@busch.com.mx

## Netherlands

Busch B.V.  
Pompomolenlaan 2  
3447 GK Woerden  
Phone: +31 348-462300  
Fax: +31 348-422939  
e-mail: info@busch.nl

## New Zealand

Busch New Zealand Ltd.  
Unit D, 41 Arrenway Drive  
Albany, Auckland 1330  
Phone: +64 9 414 7782  
Fax: +64 9 414 7783  
e-mail: sales@busch.co.nz

## Norway

Busch Vakuumteknikk AS  
Hestehagen 2  
1440 Drøbak  
Phone: +47 64 98 98 50  
Fax: +47 64 93 66 21  
e-mail: busch@busch.no

## Poland

Busch Polska Sp. z o.o.  
Ul. Chopina 27  
87-800 Wloclawek  
Phone: +48 54 2315400  
Fax: +48 54 2327076  
e-mail: busch@busch.com.pl

## Portugal

Busch Ibérica S.A., Sucursal em Portugal  
Marco da Raposa - Z.I. EN 1 Norte  
3750-753 Raso de Travassô - Agueda  
Aveiro, Portugal  
Phone: +351 234 648 070  
Fax: +351 234 648 068  
e-mail: geral@buschib.pt

## Russia

Busch Vacuum Russia OOO  
Kotlyakovskaya str., 6/9  
115201 Moscow  
Phone: +7 495 6486726  
Fax: +7 495 6486724  
e-mail: info@busch.ru

## Singapore

Busch Vacuum Singapore Pte. Ltd.  
77A Joo Koon Circle  
Singapore 629098  
Phone: +65 6488 0866  
Fax: +65 6288 0877  
e-mail: busch@busch.com.sg

## South Africa

Busch Vacuum South Africa (Pty) Ltd.  
87 Mimetes Road  
Denver  
Johannesburg  
Phone: +27 11 856 0650/6  
Fax: +27 11 856 0625  
e-mail: joe.jagger@busch.co.za

## Spain

Busch Ibérica S.A.  
Pol. Ind. Coll de la Manyà  
C/ Jaume Ferran, 6-8  
08403 Granollers  
Phone: +34 93 861 61 60  
Fax: +34 93 840 91 56  
e-mail: busch@buschib.es

## Sweden

Busch Vakuumteknik AB  
Bråta Industriområde  
435 33 Mölnlycke  
Phone: +46 31-338 00 80  
Fax: +46 31-338 00 89  
e-mail: info@busch.se

## Switzerland

Busch AG  
Waldweg 22  
4312 Magden  
Phone: +41 61 / 845 90 90  
Fax: +41 61 / 845 90 99  
e-mail: info@busch.ch

## Taiwan

Busch Taiwan Corporation  
1F. No. 69, Sec. 3, Beishen Road  
Shenkeng Township,  
Taipei County 222  
Phone: +886 2 2662 0775  
Fax: +886 2 2662 0796  
e-mail: info@busch.com.tw

## Thailand

Busch Vacuum (Thailand) Co., Ltd.  
29/10 Moo 7, Soi Poolchareon,  
Bangna-Trad Road,  
Bangchalong, Bangplee  
Samutprakarn 10540  
Phone: +66 2 3370360-2  
Fax: +66 2 3370363  
e-mail: info@busch.co.th

## Turkey

VAKUTEK  
Emlak Kredi Ishani No: 179  
34672 Üsküdar-Istanbul  
Phone: +90 216 310 0573  
Fax: +90 216 343 5126  
e-mail: vakutek@ttnet.net.tr

## United Arab Emirates

Busch Vacuum FZE  
A-3/71, Sharjah Airport International Free zone (SAIF-Zone),  
P.B.No: 121855, Sharjah  
Phone: +971 06 5529 174  
Fax: +971 6 5528 653  
e-mail: abhishek.sharma@busch.ae

## United Kingdom

Busch (UK) Ltd  
Hortonwood 30  
Telford Shropshire TF1 7YB  
Phone: +44 1952 677 432  
Fax: +44 1952 677 423  
e-mail: sales@busch.co.uk

## USA

Busch LLC  
516-B Viking Drive  
Virginia Beach, VA 23452  
Phone: +1 757 463-7800  
Fax: +1 757 463 7407  
e-mail: marketing@buschusa.com