

Instruction Manual

EXDC Turbomolecular Pump Drive Modules

Description

Item Number

EXDC80 Turbomolecular Pump Drive Module

D396-40-000

EXDC160 Turbomolecular Pump Drive Module

D396-41-000



Declaration of Conformity

We, BOC Edwards,
Manor Royal,
Crawley,
West Sussex RH10 2LW, UK

declare under our sole responsibility that the product(s)

EXDC80 Drive Modules	D396-40-000
	D396-40-508
	D396-40-800

EXDC160 Drive Modules	D396-41-000
	D396-42-508
	D396-42-800

to which this declaration relates is in conformity with the following standard(s)
or other normative document(s)

EN61010-1:2001	Safety Requirements for Electrical Equipment for Measurement, Control and Laboratory Use.
EN61326:1997 + A1:1998 + A2:2001 (Class B Emissions)	Electrical Equipment for Measurement, Control and Laboratory Use - EMC Requirements.
CSA C22.2 No. 0 UL3101.1	General Requirements - Canadian Electrical Code Part II Electrical Equipment for Laboratory Use. Part I: General Requirements.

following the provisions of

73 / 023 / EEC	Low Voltage Directive.
89 / 336 / EEC	Electromagnetic Compatibility Directive.



Dr. J.D. Watson, Director of Technology, VEMD

14 JUNE 2005 BURGESS HILL

Date and Place

This product has been manufactured under a quality system registered to ISO9001

 **BOC EDWARDS**

CONTENTS

Section	Title	Page
1	INTRODUCTION	1
1.1	Scope and definitions	1
1.2	Description	2
1.3	Logic interface	2
1.4	Indicator LEDs	2
2	TECHNICAL DATA	4
2.1	Operating and storage data	4
2.2	Mechanical data	4
2.3	Electrical data	4
3	INSTALLATION	7
3.1	Unpack and inspect	7
3.2	Adjust the electrical connector position (optional)	7
3.3	Fit the EXDC to the EXT pump	7
3.4	Electrical connections	8
3.4.1	Introduction	8
3.4.2	Connect the logic interface to your control equipment	8
3.4.3	Connect the electrical supply	10
4	OPERATION	11
4.1	Start-up	11
4.2	Operation with high inlet pressure or temperature	11
4.3	Normal shutdown	12
4.4	Shut down due to pump under or over-speed	12
4.5	Electrical supply failure	13
5	MAINTENANCE	14
5.1	Introduction	14
5.2	EXDC LED fault finding	14
6	STORAGE AND DISPOSAL	15
6.1	Storage	15
6.2	Disposal	15
	RETURN OF BOC EDWARDS EQUIPMENT	

Illustrations

Figure	Title	Page
1	The EXDC	3
2	Dimensions (mm)	5
3	Schematic diagram of the logic interface connections	9

Tables

Table	Title	Page
1	Logic interface connector pins	8
2	EXDC LED fault finding	14

Associated Publications

Publication Title	Publication Number
EXT Pump Accessories	B580-66-880
EXT70 and EXT250 Turbomolecular Pumps	B722-01-880
EXT351 and EXT501 Turbomolecular Pumps	B727-20-880
EXT70H, EXT70Hi, EXT250H and EXT250Hi Compound Molecular Pumps	B740-01-880
EXT255H and EXT255Hi Compound Molecular Pumps	B753-03-880

1 INTRODUCTION

1.1 Scope and definitions

This manual provides installation, operation and maintenance instructions for the BOC Edwards EXDC80 and EXDC160 Turbomolecular Pump Drive Modules (abbreviated to EXDC in the remainder of this manual). You must use the EXDC as specified in this manual. If you do not, the protection provided by the EXDC may be impaired, or you may damage the EXDC, or cause injury to people.

Read this manual before you install and operate the EXDC. Important safety information is highlighted as WARNING and CAUTION instructions; you must obey these instructions. The use of WARNINGS and CAUTIONS is defined below.

WARNING

Warnings are given where failure to observe the instruction could result in injury or death to people.

CAUTION

Cautions are given where failure to observe the instruction could result in damage to the equipment, associated equipment or process.

The units used throughout this manual conform to the SI international system of units of measurement.

In accordance with the recommendations of IEC1010, the following warning symbols appear on the EXDC:



Caution - refer to accompanying documents



Caution - hot surface.

1.2 Description

The EXDC controls the electrical supply for a BOC Edwards EXT70, EXT70H, EXT250, EXT255H, EXT351 or EXT501 turbomolecular pump.

The EXDC has no manual controls and can only be operated through the logic interface. To operate the EXT pump, you must therefore connect the EXDC to your own control equipment and electrical supply (see Figure 3).

Two models of EXDC are available, the only difference between the two models is the output power provided to the EXT pump: see Section 2.

1.3 Logic interface

The EXDC has a 9-way logic interface connector on the end of the logic interface cable (Figure 1, item 3). You must use a suitable connector mating half (not supplied) to connect the EXDC to your own equipment: refer to Section 2.3 for the connector mating-half type and to Section 3.4 for the electrical connections.

Refer to Table 1 and Figure 3 for detailed information about the logic interface connector pins and their uses.

1.4 Indicator LEDs

Refer to Figure 1. The EXDC has four indicator LEDs, as follows:

Phase LEDs (4)	These red LEDs are on when the corresponding phase output to the EXT pump motor is on.
TMP Normal LED (5)	This green LED is on when the EXT pump is 80% or more of full rotational speed.

You can use these LEDs as an aid to fault finding: refer to Section 5.2.

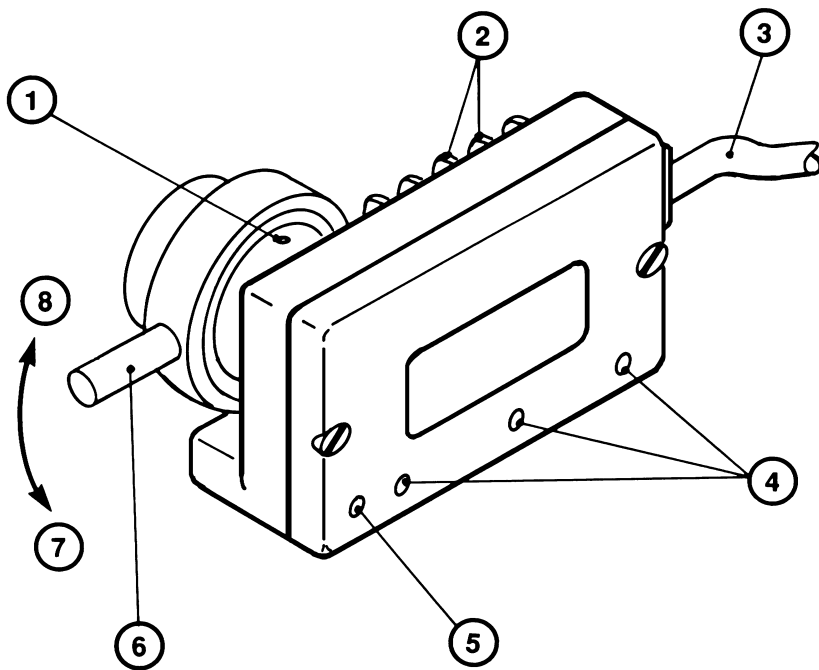

AG/2876/A

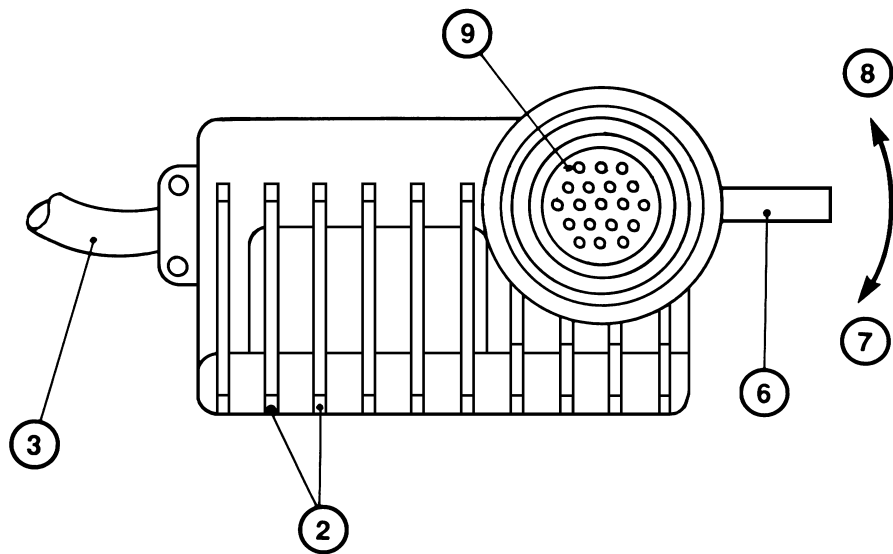

- | | |
|--------------------------|---------------------------|
| 1. Grub screw | 5. TMP Normal LED (green) |
| 2. Cooling fins | 6. Connector lock |
| 3. Logic interface cable | 7. Unlocked position |
| 4. Phase LEDs (red) | 8. Locked position |
| | 9. EXT pump connector |

Figure 1 - The EXDC

2 TECHNICAL DATA

2.1 Operating and storage data

Ambient operating temperature range	0 to 40 °C
Ambient storage temperature range	-20 to 70 °C
Maximum ambient operating humidity	10 to 95% RH (non-condensing to DIN 40040)
Maximum operating altitude	3000 m
Cooling	Natural convection
Radiated electromagnetic emission	EN50081-1
Electromagnetic immunity	EN50082-1

2.2 Mechanical data

Dimensions	See Figure 2
Mass	0.2 kg
Enclosure protection	IP20 (as defined by IEC529)
Pollution degree	IEC664, category 1

2.3 Electrical data

Electrical supply requirements

- The EXDC electrical supply must meet the requirements of IEC1010-1/C22.2 1010-1.
- The safety earth (ground) impedance must be $< 0.1 \Omega$.
- The EXDC 0 V is not referenced to earth (ground). Ensure that the electrical supply offers a path ($\leq 22 \text{ k}\Omega$) between 0 V and earth (ground).

Maximum continuous output power

EXDC80	80 W
EXDC160	160 W

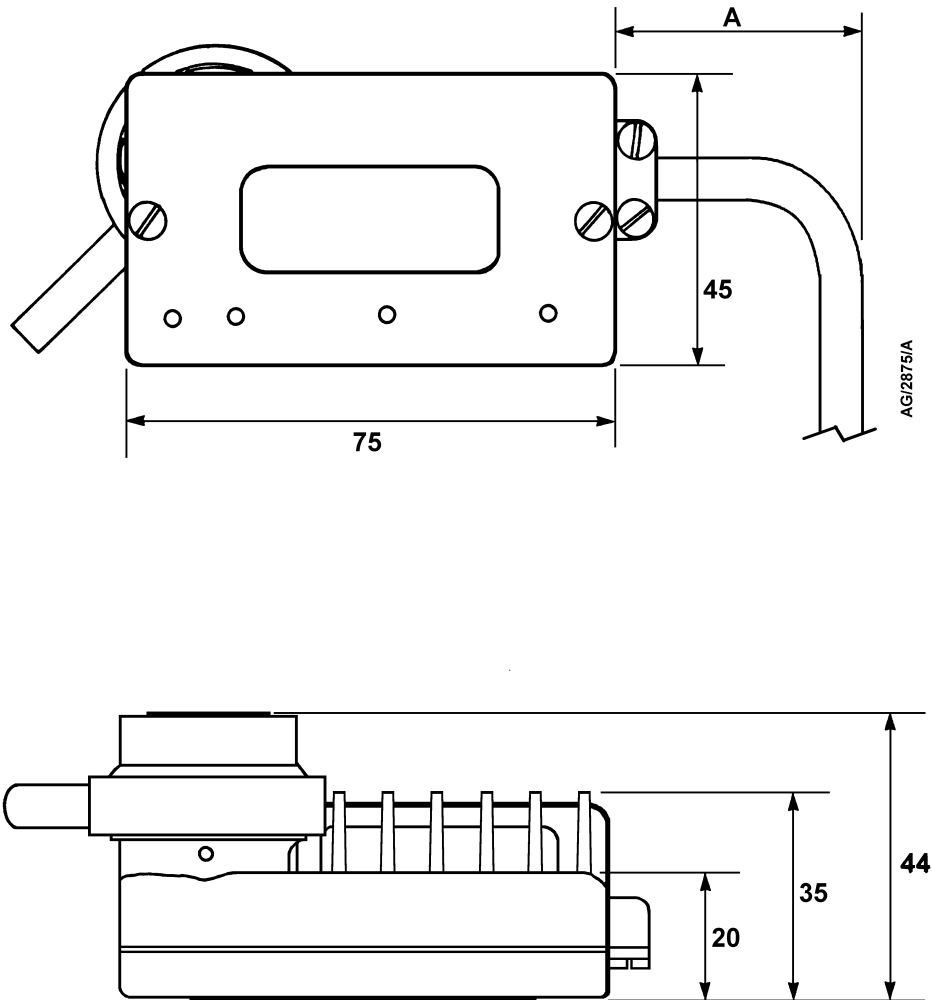

A Cable bend radius (≥ 30)

Figure 2 - Dimensions (mm)

Logic interface

Connector mating half *	9-way D-type male
EXDC electrical supply	
Allowable voltage range	70 to 85 V d.c.
Undervoltage lock-out voltage	> 63 V
Maximum voltage ripple	2 V r.m.s.
Fuse (or equivalent current limiting device) rating	3.15 A type 'T' IEC approved or 3.2 A time delay fuse UL/CSA approved
Maximum input current	1.1 A (EXDC80) 2.2 A (EXDC160)
Start/stop control input signal	
Start control voltage: low (close)	< 0.8 V d.c.
Stop control voltage: high (open)	4 to 24 V d.c.
Speed analogue output	
Output voltage	0 to +10 V d.c. (directly proportional to pump speed, that is 0 to 10 V \cong 0 to 100% of pump speed)
Output impedance	0.1 Ω
Minimum load	≥ 5 k Ω
TMP Normal status output	
Type	Open collector transistor
< 80 %	Off (pull up to 15 V d.c.)
≥ 80 %	On (< 0.8 V d.c.)
Rating	20 mA

* Not supplied

3 INSTALLATION

3.1 Unpack and inspect

Remove all packing materials and check the EXDC. If the EXDC is damaged, notify your supplier and the carrier in writing within three days; state the Item Number of the EXDC together with your order number and your supplier's invoice number. Retain all packing materials for inspection. Do not use the EXDC if it is damaged.

If the EXDC is not to be used immediately, store the EXDC in suitable conditions, as described in Section 6.

3.2 Adjust the electrical connector position (optional)

CAUTION

Do not turn the pump electrical connector more than 180° from its orientation as supplied. If you do, you may damage the wires inside the EXDC.

Refer to Figure 1. Use the following procedure to adjust the position of the EXT pump connector (9) and connector lock (6) with respect to the EXDC body.

1. Use a hexagonal key to loosen the grub screw (1).
2. Turn the connector (9) and lock (6) to the required orientation: you can turn the connector and lock up to 180° clockwise or anticlockwise.
3. Tighten the grub screw (1) to secure the connector and connector lock.

3.3 Fit the EXDC to the EXT pump

1. Refer to Figure 1. Look at the front of the EXDC (that is, with the LEDs (4, 5) towards you), then turn the connector lock (6) fully anticlockwise (in direction 7).
2. Fit the connector (9) directly to the pump to Controller connector on the EXT pump: refer to the EXT pump instruction manual.
3. Turn the lock (6) fully clockwise (in direction 8) to lock the connectors and secure the EXDC in position.

3.4 Electrical connections

3.4.1 Introduction

Use a suitable connector mating half (not supplied) to connect the electrical supplies and your control equipment to the connector on the logic interface cable (Figure 1, item 3). When you make the electrical connections to the EXDC described in the following sections, refer to Table 1 for full details of the logic interface connections and to Figure 3 for a schematic diagram of the connections.

Pin number	Signal	Polarity	Use
1	Start/Stop control input	-	Close * to start EXT pump.
2	TMP Normal status output	-	Closed * when EXT pump speed is 80% or more of full rotational speed.
3	Earth (ground)	-	
4	Pump speed analogue output	Positive	
5, 6	Electrical supply: 0 V	-	
7, 8	Electrical supply: 80 V	Positive	

* With respect to pins 5 or 6.

Table 1 - Logic interface connector pins

3.4.2 Connect the logic interface to your control equipment

1. Connect your control equipment to the start/stop control input pins of your logic interface mating half to start/stop the EXT pump as required:
 - Link (close) the start/stop control input (pin 1) to pins 5 or 6 to start the EXT pump.
 - Unlink (open) the start/stop control input (pin 1) from pins 5 or 6 to stop the EXT pump.
2. Connect your control equipment to the pump speed analogue output (pin 4) and to pins 5 or 6 of your logic interface mating half to monitor the speed output of the EXDC.

(Continued on page 10)

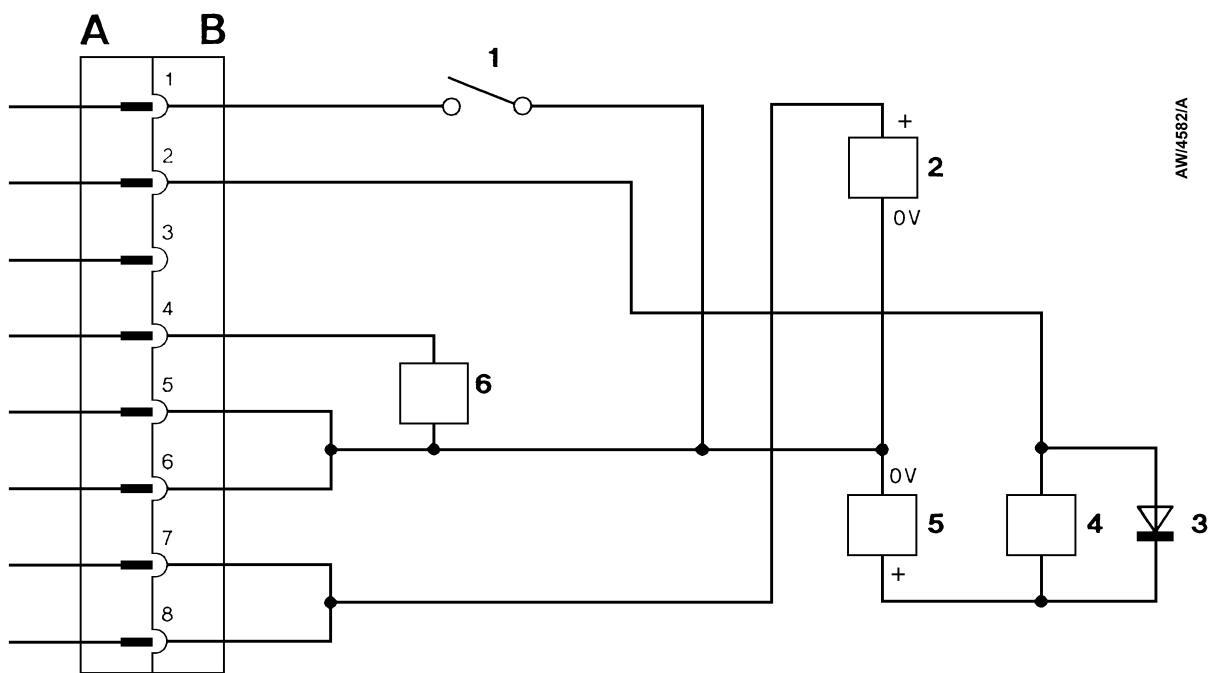

AW/4562/A

- A EXDC logic interface plug
 B Mating half to EXDC logic interface plug
- | | |
|--|----------------------------------|
| 1. Start/stop switch | 4. D. C. relay (optional) |
| 2. Electrical supply | 5. Relay power supply (optional) |
| 3. Back EMF suppression diode (optional) | 6. Voltmeter |

Figure 3 - Schematic diagram of the logic interface connections

3. Connect your control equipment to the TMP normal status output (pin 2) and to pins 5 or 6 of your logic interface mating half. You can use the output to control other devices in your pumping system. The output can drive a low power relay of up to 24 V coil rating.

3.4.3 Connect the electrical supply

WARNING

Ensure that the EXDC is earthed (grounded) as required by IEC1010-1\C22.2 1010-1 and all local legislative requirements, and observe all appropriate safety precautions for the safe installation and handling of electrical equipment. If you do not, there will be a danger of injury or death to people by electric shock.

WARNING

Incorporate a suitable isolation device in the electrical supply, close to the EXDC. If you do not, you will not be able to switch off the EXDC in an emergency.

WARNING

Incorporate suitable fuses or current limiting devices in the electrical supply circuit. If you do not and a fault develops, the EXDC may be damaged and there will be a danger of injury or death to people by electric shock.

Connect suitable electrical supplies to pins 5 to 8 of your connector mating half. When you connect the supplies:

- Incorporate a suitable fuse or current limiting devices in your external electrical supply: the rating of the fuse or current limiting device must be suitable for your electrical supply.
- Incorporate suitable fuses or current limiting devices in the nominal 80 V lines: refer to Section 2 for the fuse/current limiting device rating.
- Incorporate an isolation switch.

4 OPERATION

WARNING

Do not disconnect the EXDC from the EXT pump when the pump is operating. At full speed, the EXT pump motor generates 48 V RMS which is accessible at the pump to Controller electrical connection, and there may be a risk of injury by electric shock.

CAUTION

Do not disconnect the EXDC from, or reconnect the EXDC to, the EXT pump if the electrical supply to the EXDC is on, or if the EXT pump is rotating. If you do, you can damage the EXDC.

4.1 Start-up

Notes: You can start the backing pump and the EXT pump at the same time; the EXT pump will not be damaged and can operate as an effective baffle. However, if the system pressure remains too high, the EXT pump may not reach 80% of full rotational speed and the TMP Normal status output signal will not be set.

Use the following procedure to start up your system. This procedure assumes that you will manually operate the vent-valve and the backing pump.

1. Switch on the electrical supply to the EXDC.
2. Close the vent-valve (if fitted) and start the backing pump.
3. Start the EXT pump: close the Start/Stop control input on the logic interface connector.

4.2 Operation with high inlet pressure or temperature

If the EXT pump inlet pressure rises, the power supplied by the EXDC to the pump-motor will increase to counteract the gas frictional load. The pump rotational speed will remain constant until the EXDC peak power level is reached; beyond this power level, the speed of the pump will start to reduce.

(Continued on page 12)

Temperature sensors in the EXDC and the EXT pump are monitored by the EXDC. If the EXDC detects that the pump temperature or its own temperature is too high, the power supplied to the pump-motor is reduced; the pump may not therefore be able to maintain full rotational speed if it is too hot.

Refer to the EXT pump instruction manual for the maximum allowable inlet pressure and for the pump operating temperature ranges, and refer to Section 2.3 for the maximum EXDC output power.

4.3 Normal shutdown

Use the following procedure to shut down your system. This procedure assumes that you will manually operate the vent-valve and the backing pump. Refer to the Instruction Manual for the EXT pump for details of the maximum allowable vent rate.

1. Select Stop: open the Start/Stop control input on the logic interface connector.
2. Open the vent-valve after the EXT pump speed has fallen to below 50% of full rotational speed.
3. Switch off the backing pump.

4.4 Shut down due to pump under or over-speed

CAUTION

Shut down the EXT pump if its speed falls to below 50% of full rotational speed. If you do not, the EXT pump may be damaged.

You must use the speed analogue output to monitor the speed of the EXT pump. If the pump speed falls to below 50% of its full rotational speed, this means that there is high inlet pressure or temperature, or that there is a fault in the EXT pump (for example, the bearings may have failed).

If the pump speed falls to below 50% of its full rotational speed, you must therefore switch off the EXT pump (open the start/stop control input) to prevent damage to the pump.

The EXDC has an electronic EXT pump speed control system. This control system prevents operation of the EXT pump at over 100% of its normal full rotational speed (as operation above this speed reduces bearing operational life).

If required, you can monitor the speed analogue output and configure your control equipment to switch off the EXT pump if its speed exceeds 100% of full rotational speed.

4.5 Electrical supply failure

WARNING

If the Start/Stop control signal on the logic interface connector is set to Start, the EXDC will automatically restart the EXT pump when the electrical supply is restored after an electrical supply failure. Ensure that people cannot be injured by the rotating rotor blades of the EXT pump.

If the electrical supply to the EXDC fails when the EXT pump is rotating, the motor of the EXT pump acts as a generator and the power generated can be used as the electrical supply for the associated control logic connected to the EXDC.

You can connect a suitable d.c. to d.c. convertor to the 80 V supply pins (pins 7, 8) on your logic interface mating half; the voltage on these pins is maintained at 50 V d.c. during external electrical supply failure.

5 MAINTENANCE

5.1 Introduction

The EXDC has no parts which can be serviced by the user. If necessary, return the EXDC to your supplier or BOC Edwards for repair or replacement.

5.2 EXDC LED fault finding

Symptom	Check	Action
None of the LEDs are on.	Has the EXDC electrical supply failed ?	Ensure that the electrical supply is switched on and that the fuses (and current limiting devices) have not been tripped.
The Normal LED does not go on.	Is there a leak in the vacuum system ? Is the EXT pump faulty ?	Inspect the vacuum system and seal any leaks found. Inspect the EXT pump and check that it operates correctly with another EXDC or EXC Turbomolecular Pump Controller. If necessary, replace the EXT pump.
Only one phase LED is on.	Is the EXT pump faulty ?	Inspect the EXT pump and check that it operates correctly with another EXDC or EXC Turbomolecular Pump Controller. If necessary, replace the EXT pump.
(Any of the above.)	-	If all the previous checks and actions have been made and the fault symptom is still present, the EXDC may be faulty: contact your supplier or BOC Edwards.

Table 2 - EXDC LED fault finding

6 STORAGE AND DISPOSAL

6.1 Storage

Fit protective covers over the electrical connections and store the EXDC in clean dry conditions until required.

When required for use, prepare and install the EXDC as described in Section 3 of this manual.

6.2 Disposal

Dispose of the EXDC and any components safely in accordance with all local and national safety and environmental requirements.