

Instruction Manual

XDS-C Dry Pump

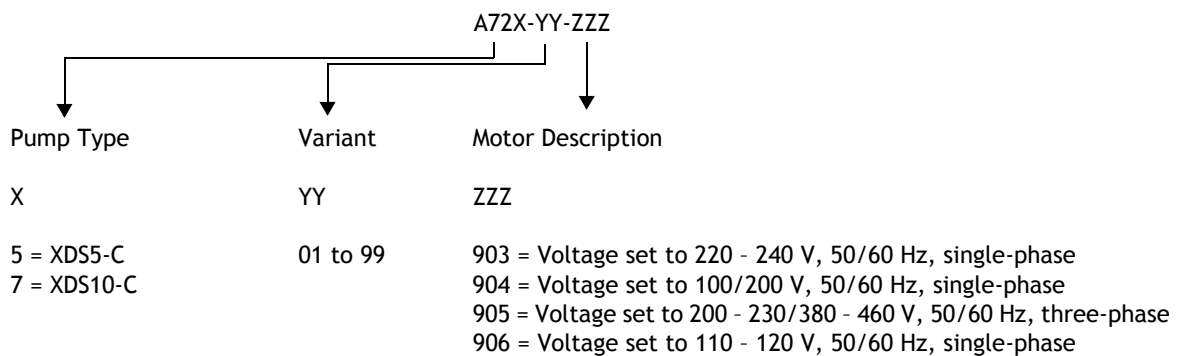

Declaration of Conformity

We, BOC Edwards,
Manor Royal,
Crawley,
West Sussex, RH10 2LW, UK

declare under our sole responsibility that the product(s)

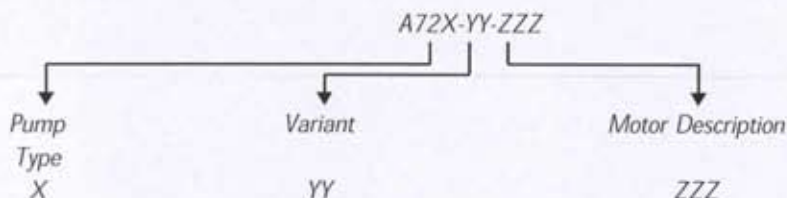

5 = XDS5-C
7 = XDS10-C

01 to 99

903 = Voltage set to 220 - 240V, 50/60Hz, single phase
904 = Voltage set to 100/200V, 50/60Hz, single phase
906 = Voltage set to 110 - 120V, 50/60Hz, single phase

to which this declaration relates is in conformity with the following standard(s) or other normative document(s)

EN292	Safety of Machinery: Basic Concepts, General Principles for Design.
IEC34 Parts 1, 5, 8 ⁺ , 11 [*]	General Requirements for Rotating Electrical Machines.
EN1012-2	Compressors and Vacuum Pumps - Safety Requirements Part 2.
EN61010-1 [*]	Safety Requirements for Electrical Equipment for Measurement Control and Laboratory Use.
C22.2 No1010.1.92	Safety Requirements for Electrical Equipment for Measurement, Control and Laboratory Use. Part 1: General Requirements.
UL3101.1 [#]	Electrical Equipment for Laboratory Use. Part 1: General Requirements.
EN13463-1	Non Electrical Equipment for Potentially Explosive Atmospheres.

The pumps comply with EN61010-1 when installed in accordance with the instruction manual supplied with the pumps.

following the provisions of

73/023/EEC	Low Voltage Directive.
89/336/EEC	Electromagnetic Compatibility Directive.
94/9/EC	Equipment for use in Potentially Explosive Atmospheres (ATEX Directive) (Category 3GD) Internal Atmospheres Only.
98/37/EC	Machinery Directive.

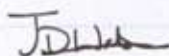

Dr. J. D. Watson, Senior Technical Manager
Vacuum Equipment and Exhaust Management Product Divisions

17 JUNE 2003 Stoneham
Date and Place

This product has been manufactured under a quality system registered to ISO9001

Contents

Section	Page
1	Introduction 1
1.1	Scope and definitions 1
1.2	ATEX directive implications 2
1.3	Description 2
1.4	Gas-ballast control 4
1.5	Construction 4
2	Technical Data 5
2.1	Operating and storage conditions 5
2.2	Performance 5
2.2.1	General 5
2.2.2	Performance characteristics 6
2.3	Mechanical data 8
2.3.1	General 8
2.3.2	Noise and vibration data 8
2.4	Electrical data 8
2.4.1	Single-phase pumps 8
2.4.2	Three-phase pumps 8
2.5	Legislation and standards 9
3	Installation 11
3.1	Safety 11
3.2	System design considerations 11
3.3	Unpack and inspect 11
3.4	Lifting the pump 12
3.5	Locate the pump 12
3.6	Electrical installation: single-phase pumps 12
3.6.1	Check and configure the motor 12
3.6.2	Connect the pump to your electrical supply 13
3.6.3	Check the direction of rotation 14
3.7	Electrical installation: three-phase pumps 14
3.7.1	Check and configure the motor 14
3.7.2	Connect the pump to your electrical supply 16
3.7.3	Check the direction of rotation 16
3.8	Inlet and outlet connections 17
3.9	Leak test the system 17
4	Operation 19
4.1	Gas-ballast control 19
4.2	Start up procedure 19
4.3	To achieve ultimate vacuum 19
4.4	To pump condensable vapours 20
4.5	Implication of ATEX directive 20
4.5.1	Introduction 20
4.5.2	Flammable/pyrophoric materials 20
4.5.3	Gas purges 21
4.6	Shut down 21

5	Maintenance	23
5.1	Safety information	23
5.2	Maintenance plan	23
5.3	Inspect and clean the inlet strainer	24
5.4	Inspect and clean the gas-ballast control	24
5.5	Clean the external fan cover	25
5.6	Replace the tip seals	25
5.7	Test the motor condition	25
5.8	Fault-finding	26
5.8.1	The pump has failed to start	26
5.8.2	The pump has failed to achieve the required performance	26
5.8.3	The pump is noisy	26
5.8.4	The pump surface temperature is above 100 °C	26
5.8.5	The pumping speed is poor	26
6	Storage and Disposal	27
6.1	Storage	27
6.2	Disposal	27
7	Spares and Accessories	29
7.1	Introduction	29
7.2	Spares	29
7.3	Accessories	29
7.3.1	Solenoid operated pipeline valve	29
7.3.2	Gas-ballast adaptor	29
7.3.3	Vibration isolators	29
7.3.4	Exhaust nozzle kit	30
7.3.5	XDS silencer	30
	Index	31

Illustrations

Figure		Page
1	The single-phase XDS-C dry pump	3
2	Performance characteristics	6
3	Dimensions	7
4	Electrical interface: single-phase pumps	13
5	Underside of the pump	15
6	Three-phase electrical connections: 200-230 V	15
7	Three-phase electrical connections: 380-460 V	15
8	Inlet strainer assembly	24
9	Gas-ballast control assembly	25

Tables

Table		Page
1	General characteristics	5
2	Performance characteristics	6
3	Dimensions (mm)	7
4	Electrical data (single-phase pumps with item numbers -903 or -906)	9
5	Electrical data (single-phase pumps with item numbers -904)	9
6	Electrical data (three-phase pumps with item numbers -905)	9
7	Wire colour codes	13
8	Maintenance plan	23
9	Solenoid operated pipeline valve	29

Associated publications

Publication title	Publication number
Vacuum Pump and Vacuum System Safety	P300-20-000

This page has been intentionally left blank.

1 Introduction

1.1 Scope and definitions

This manual provides installation, operation and maintenance instructions for the Edwards XDS5-C and XDS10-C dry pumps. You must use the XDS-C pump as specified in this manual. Read this manual before you install, operate and maintain your XDS pump.

Important safety information is highlighted as WARNING and CAUTION instructions; you must obey these instructions. The use of WARNINGS and CAUTIONS is defined below.



WARNING

Warnings are given where failure to observe the instruction could result in injury or death to people.

CAUTION

Cautions are given where failure to observe the instruction could result in damage to the equipment, associated equipment and process.

Throughout this manual, page, figure and table numbers are sequential.

The units used throughout this manual conform to the SI international system of units of measurement.

Pressures are stated as absolute pressures throughout this manual, unless otherwise stated.

The following IEC warning labels appear on the pump:



Warning - refer to accompanying documentation.



Warning - risk of electric shock.



Warning - hot surfaces.

1.2 ATEX directive implications

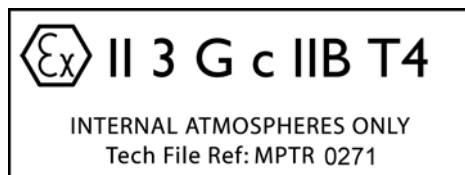

- This equipment is designed to meet the requirements of Group II Category 3 equipment in accordance with Directive 94/9/EC of the European Parliament and the Council of 23rd March 1994 on the approximation of the laws of the Member States concerning equipment and protective systems intended for use in potentially explosive atmospheres. (The ATEX Directive)

The ATEX Category 3 applies in respect of potential ignition sources internal to the equipment. An ATEX Category has not been assigned in respect of potential ignition sources on the outside of the equipment as the equipment has not been designed for use where there is an external potentially explosive atmosphere.

There is no potential source of ignition within the pump during normal operation but there may be potential sources of ignition under conditions of predicted and rare malfunction as defined in the Directive. Accordingly, although the pump is designed to pump flammable materials and mixtures, operating procedures should ensure that under all normal and reasonably predicted conditions, these materials and mixtures are not within explosive limits. Category 3 is considered appropriate for the avoidance of ignition in the case of a rare malfunction which allows flammable materials or mixtures to pass through the pump while within their explosive limits.

- When flammable materials are present within the equipment you must:
 - Not allow air to enter the equipment.
 - Ensure the system is leak tight.

For further information, please refer to the back page of this instruction manual for the contact details of your nearest Edwards.

1.3 Description

The XDS-C pump is shown in [Figure 1](#). Refer to [Figure 1](#) for item numbers in brackets in the following descriptions.

The XDS-C pump is a compact, reliable vacuum pump which is suitable for use on vapour handling processes. The XDS-C pump is not suitable for use with explosive, toxic or corrosive substances, or substances that contain or produce particulates or powders.

The body of the pump includes a fixed scroll and an orbiting scroll. The orbiting scroll is driven by the electric motor through an eccentric cam on the motor drive shaft. The movement of the orbiting scroll, meshed with the fixed scroll, forms successive crescent shaped volumes in the pump. Gas which enters the pump through the inlet is compressed by the movement of the orbiting scroll and swept towards the centre of the fixed scroll. The compressed gas enters the exhaust port near the centre of the stationary scroll and is exhausted from the pump through the outlet.

The XDS-C pump is a dry vacuum pump, as all the bearings, with their hydrocarbon lubricant, are isolated from the vacuum space.

The inlet of the pump is fitted with a removable inlet strainer which prevents the entry of debris into the pump.

The pump mechanism is driven directly by a single-phase or three-phase electric motor. Single-phase motors are fitted with an on/off switch (7) and a thermal overload device. When the motor is too hot, the thermal overload device switches off the pump. The thermal overload device has an automatic reset; when the motor cools down, the device resets and (unless you have incorporated suitable control equipment which must be manually reset), the motor will restart.

The pump is air-cooled by a fan mounted at the opposite end to the motor.

The pump is mounted on a bespatter on rubber feet. Details of suitable vibration isolators and other accessories are provided in [Section 7](#).

Figure 1 - The single-phase XDS-C dry pump



- | | |
|----------------------------|----------------------|
| 1. NW25 inlet port | 5. Bespatter |
| 2. Gas-ballast control | 6. Voltage indicator |
| 3. Cooling fan | 7. On/off switch |
| 4. DN25NW/3/4" BSP exhaust | 8. Hour counter |

1.4 Gas-ballast control

To pump high vapour loads, gas-ballast is delivered into the pump to prevent condensation of the vapour carried by the pumped gases.

Air can be introduced to the low vacuum stages through the gas-ballast valve. Alternatively, an inert gas such as nitrogen can be supplied through a suitable external valve.

The gas-ballast control has three positions:

- Closed (position '0')
- Low flow (position 'I')
- High flow (position 'II')

1.5 Construction

The pump scrolls are made from anodised aluminium and the motor housing made from aluminium only. All surfaces of the pump which are exposed to the pumped gases are free from copper, zinc and cadmium.

2 Technical Data

2.1 Operating and storage conditions

Ambient temperature:

Operating range 10 °C to 40 °C

Storage range -30 °C to 70 °C

Surface temperature of pump above ambient (when operating at ultimate) typically 45 °C

Maximum humidity (operation) 90%

Altitude up to 2000 m

2.2 Performance

2.2.1 General

General characteristics of the pumps are defined in [Table 1](#) below. Characteristics shown are displacement, pumping speed and maximum permitted interface pressures.

Suckback on pump switch off typically 30 mbar Is⁻¹ (leak tightness 1x10⁻⁶ mbar Is⁻¹).

Table 1 - General characteristics

	XDS 10-C	XDS 5-C
Maximum displacement (m ³ /hr) 50 Hz electrical supply 60 Hz electrical supply	11.3 13.4	5.7 6.7
Maximum pumping speed (m ³ /hr) Pneurop 6602 (1979) 50 Hz electrical supply 60 Hz electrical supply	9.3 11.1	4.8 6.0
Maximum permitted inlet pressure and gas-ballast inlet pressure	0.5 bar gauge	0.5 bar gauge
Maximum permitted outlet pressure	1 bar gauge	1 bar gauge

2.2.2 Performance characteristics

The position of the gas-ballast control defines the performance characteristics of the pump. These performance characteristics are listed fully in Table 2.

The curves shown in Figure 2 show the relationship between inlet pressure and pumping speed for the pump.

Table 2 - Performance characteristics

Parameter	Units	XDS 10-C	XDS 5-C
Gas-ballast control closed (position '0') typical ultimate vacuum (total pressure)	mbar Pa	9×10^{-1} 90	9×10^{-1} 90
Gas-ballast control closed (position '1') typical ultimate vacuum (total pressure)	mbar Pa	3×10^0 300	3×10^0 300
Gas-ballast flow water vapour pumping capacity	l / min g / hr	3 70	3 70
Gas-ballast control closed (position '2') typical ultimate vacuum (total pressure) 50 Hz	mbar Pa	5×10^0 500	5×10^0 500
Gas-ballast flow water vapour pumping capacity water vapour tolerance	l / min g / hr mbar Pa	15 > 200 35 5×10^3	15 > 200 50 3.5×10^3

Figure 2 - Performance characteristics

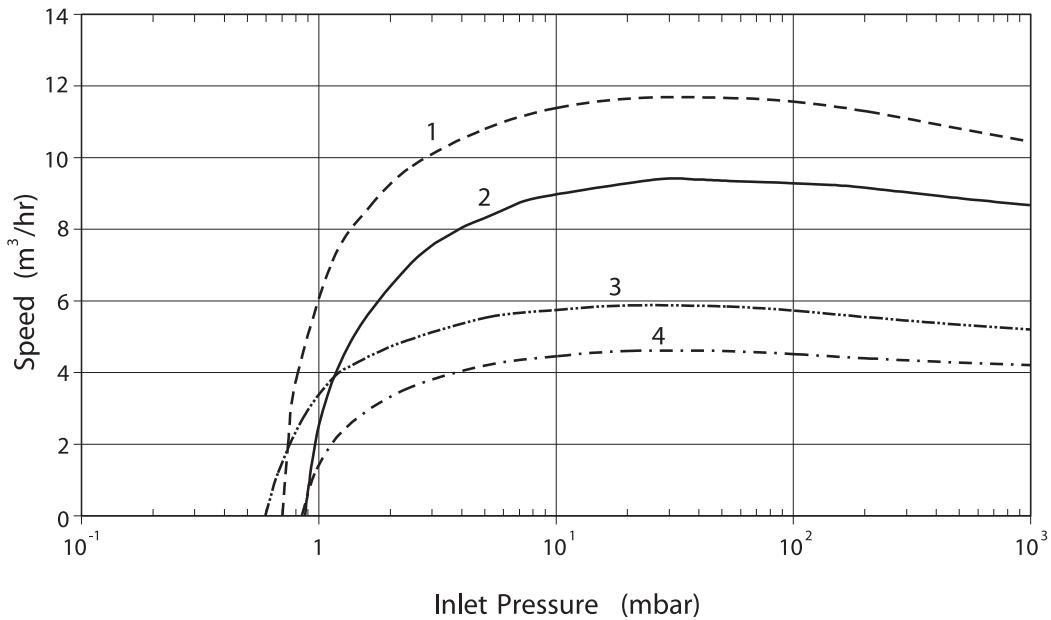

1. XDS10-C 60 Hz
2. XDS10-C 50 Hz
3. XDS5-C 60 Hz
4. XDS5-C 50 Hz

Figure 3 - Dimensions

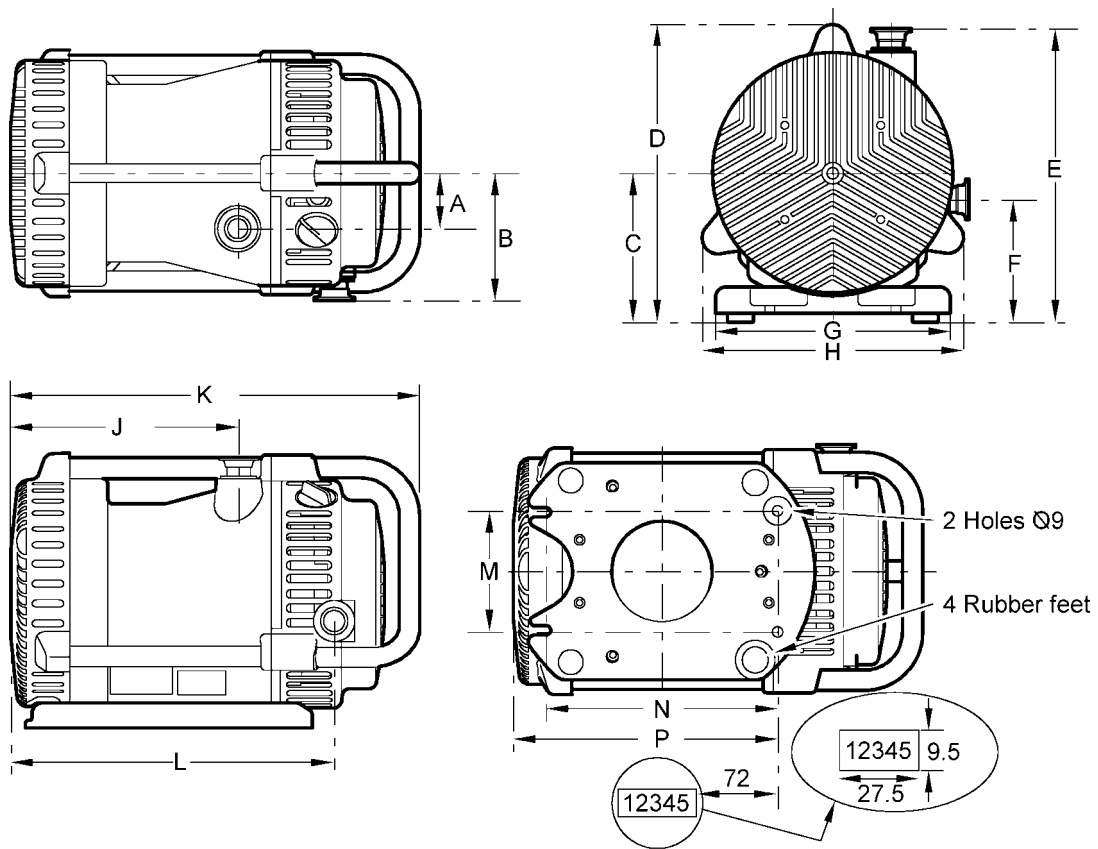

Bottom of hour counter is 44 mm above the floor

dc5/0188/001

from motor end to centre of single phase socket = 200 mm
 from motor end to centre on/off = 124 mm
 Refer to Table 3 for dimensions

Table 3 - Dimensions (mm)

Dimension Reference (Refer to Figure 3)	XDS5-C	XDS10-C
A =	55	55
B =	135	135
C =	147	147
D =	290	290
E =	288	288
F =	133	133
G =	220	220
H =	249	249
J =	210	210
K =	427	427
L =	297	315
M =	120	120
N =	230	230
P =	275	275

2.3 Mechanical data

2.3.1 General

Maximum tilt angle	10°
Motor rotational speed (50 Hz supply)	1440 rpm
Motor rotational speed (60 Hz supply)	1730 rpm
Mass (kg)	XDS5-C = 23 XDS10-C = 24.5
Inlet / outlet connections	DN25NW
Overall dimensions (mm)	427 x 290 x 249

2.3.2 Noise and vibration data

Sound pressure measured at ultimate vacuum pump to ISO 11201	55 dB(A) at 1 m
Vibration: measured at the inlet port to ISO 10816-1: 1995	Class 1C <4.5 mms ⁻¹ (rms)

2.4 Electrical data

2.4.1 Single-phase pumps

The dual voltage, dual frequency motor is designed for a single-phase electrical supply and is suitable for 50 Hz or 60 Hz operation (refer to [Tables 4 and 5](#) for the electrical data). The motor can be manually switched between nominal supply voltages of 110-120 V and 220-240 V (refer to [Section 3.6](#)).

2.4.2 Three-phase pumps

The dual voltage, dual frequency motor is designed for a three-phase electrical supply and is suitable for 50 Hz or 60 Hz operation (refer to [Table 6](#) for the electrical data). The motor can be manually switched between nominal supply voltages of 220-240 V and 380-460 V electrical supplies (refer to [Section 3.7](#)). Pumps are supplied pre-set to 380-460 V electrical supplies.

2.5 Legislation and standards

The standards and legislation with which the XDS-C pump complies are listed in full on the Declaration of Conformity on the inside cover of this manual.

Table 4 - Electrical data (single-phase pumps with item numbers -903 or -906)

Pump	Nominal Supply (V)	Frequency (Hz)	Power (W)	Current (A)	Recommended Fuse Rating (A)
XDS5-C and XDS10-C	220 - 240	50	250	3.6	5
	230 - 240	60	300	3.2	5
	110	50	250	7.2	10
	115 - 120	60	300	6.4	10

Table 5 - Electrical data (single-phase pumps with item numbers -904)

Pump	Nominal Supply (V)	Frequency (Hz)	Power (W)	Current (A)	Recommended Fuse Rating (A)
XDS5-C and XDS10-C	200	50	250	4	5
	200	60	300	3.7	5
	100	50	250	8	10
	100	60	300	7.5	10

Table 6 - Electrical data (three-phase pumps with item numbers -905)

Pump	Nominal Supply (V)	Frequency (Hz)	Power (W)	Current (A)	Recommended Fuse Rating (A)
XDS5-C and XDS10-C	200 - 230	50	250	1.77	5
	200 - 230	60	300	1.80	5
	380 - 415	50	250	0.96	3
	400 - 460	60	300	1.00	3

This page has been intentionally left blank.

3 Installation

3.1 Safety



WARNING

The Edwards XDS-C dry pump is not recommended for pumping hazardous substances.

You must ensure that the XDS-C pump is suitable for your application. If you have any doubt about the suitability of the XDS-C pump for your application, refer to the Edwards guidelines on vacuum pump and vacuum system safety (see associated publications at the end of the contents list at the front of this manual).

The installation of the XDS-C pump must be performed by a suitably trained and supervised technician. Obey the safety instructions listed below when you install the XDS-C pump, especially when you connect the pump into an existing system. Details of the specific safety precautions are given at the appropriate point in the instructions.

- Wear the appropriate safety clothing when you come into contact with contaminated components. Dismantle and clean contaminated components inside a fume cupboard.
- Vent and purge your vacuum system before you start installation work.
- Ensure that the installation technician is familiar with the safety procedures which relate to the products handled by the pumping system.
- Disconnect the other components in the pumping system from the electrical supply so that they cannot be operated accidentally.

3.2 System design considerations

Consider the following points when you design your pumping system:

Use a suitable valve to isolate the pump from your vacuum system if you need to allow the pump to warm up before pumping condensable vapours or if you need to maintain vacuum when the pump is switched off.

Avoid high levels of heat input into the pump from the process gases, otherwise the pump may overheat and seize, and cause the motor thermal overload device to open.

If you use the pump in a high ambient temperature and have a high gas throughput, the temperature of the pump body may exceed 100 °C and you must fit suitable guards to prevent contact with hot surfaces.

Make sure that the exhaust pipeline cannot become blocked. If you have an exhaust isolation valve, make sure that you cannot operate the pump with the valve closed.

3.3 Unpack and inspect

Remove all packing materials, remove the pump from its packing box, remove the protective covers from the inlet and outlet ports and inspect the pump. If the pump is damaged, notify your supplier and the carrier in writing; state the item number of the pump together with your order number and your supplier's invoice number. Retain all the packing materials for inspection. Do not use the pump if it is damaged.

If the pump is not to be used immediately, replace the protective covers. Store the pump in suitable conditions, as described in [Section 6.1](#).

3.4 Lifting the pump

Although the pump is less than 25 kg and can be lifted manually, it is recommended that suitable lifting equipment is used whenever possible. The lifting equipment should be attached to the uppermost tri-bar on the pump. It should be noted that the pump may alter its position during lifting and suitable precautions should be taken.

3.5 Locate the pump

Provide a firm, level platform for the pump. Locate the pump so that the gas-ballast control and the on / off switch are accessible.

If your pump will be located inside an enclosure, make sure that there is adequate ventilation at both ends of the pump, so that the ambient temperature around the pump does not exceed 40 °C. There must be a minimum space of 25 mm between the pump and the enclosure walls.

3.6 Electrical installation: single-phase pumps

3.6.1 Check and configure the motor

CAUTION

Ensure that the motor is correctly configured for your electrical supply. If you operate the pump when the motor is not correctly configured for the electrical supply, you will damage the motor.

Refer to [Figure 4](#) for the item numbers in brackets.

Ensure that the voltage shown on the voltage indicator arrow (5) on the motor cover corresponds with your electrical supply voltage. If it does not, you must change the configuration of the pump motor to match your supply voltage; use the procedure below.

1. Undo the two screws (4) and lift off the voltage indicator moulding (2).
2. Rotate the voltage indicator moulding (2) so that the correct voltage is next to the voltage indicator arrow (5) on the terminal box cover.
3. Replace the two screws (4).

Figure 4 - Electrical interface: single-phase pumps



1. On/off switch (I = on, O = off)
2. Voltage indicator moulding
3. Cable socket
4. Voltage selector screws
5. Voltage indicator arrow

3.6.2 Connect the pump to your electrical supply



WARNING

Ensure that the electrical installation of the XDS-C pump conforms with your local and national safety requirements. It must be connected to a suitably fused and protected electrical supply and a suitable earth point.

Make the electrical connections to the pump motor with an IEC 320 cable socket (cold condition type) that satisfies your local electrical standards. A range of suitable cables are available from your supplier or Edwards.

The pump must be connected to a suitable fused and protected electrical supply and a suitable earth point.

If your XDS-C pump was supplied with an electrical supply cable, the cable will be fitted with a moulded IEC connector at one end. The other end of the cable may be fitted with a plug suitable for your local electrical supply. A cable without a plug will contain wires colour coded as follows:

1. Ensure that the on/off switch on the motor is in the 'off' position.
2. Insert the moulded IEC connector at the end of the cable into the electrical inlet connector on the motor.
3. Connect the plug (if fitted) at the other end of the cable to your electrical supply. If a plug is not fitted, connect the wires in the cable to the correct terminals of your electrical supply.

Table 7 - Wire colour codes

Convention	Earth	Neutral	Live
Europe	green and yellow	blue	brown
USA	green	white	black

3.6.3 Check the direction of rotation

CAUTION

Ensure that the pump motor rotates in the correct direction. If it does not, the pump and your vacuum system can become pressurised.

1. Remove the plastic cover over the screw in the centre of the motor back plate.
2. Use the on / off switch to switch on the electrical supply to the motor for a few seconds.
3. Check that the screw on the back of the motor rotates in the correct direction, shown by the arrow on the motor. If the direction of rotation is incorrect, switch off the electrical supply immediately and contact your supplier or Edwards for advice.

3.7 Electrical installation: three-phase pumps

3.7.1 Check and configure the motor

CAUTION

Ensure that the motor is configured correctly for your electrical supply. If you operate the pump when the motor is not configured correctly for the electrical supply, you will damage the motor.

CAUTION

Power cable rated at 70°C must be used to connect the 3 phase pump to the power supply. Failure to do so may result in cable damage if the pump is used in high ambient temperatures.

1. Place the pump on its back, exposing the underside of the pump (refer to [Figure 5](#)). Undo the 3 screws securing the access plate and remove it.
2. Ensure that the motor is correctly configured for your electrical supply. If necessary reconfigure the links (refer to [Figures 6 and 7](#)) to suit your electrical supply.
 - For 200 - 230 V electrical supplies the links must be configured as shown in [Figure 6](#).
 - For 380 - 460 V electrical supplies the links must be configured as shown in [Figure 7](#).

Figure 5 - Underside of the pump

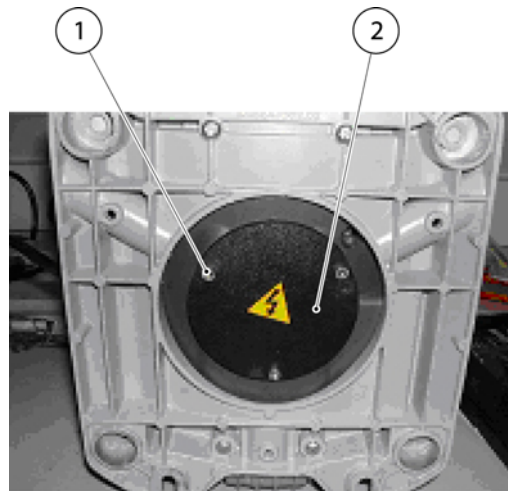

- 1. Screws
- 2. Access plate

Figure 6 - Three-phase electrical connections: 200-230 V

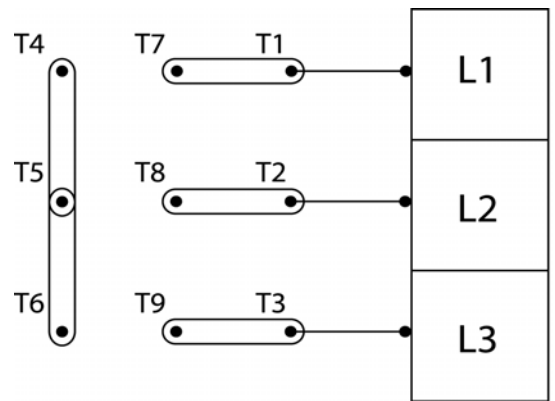
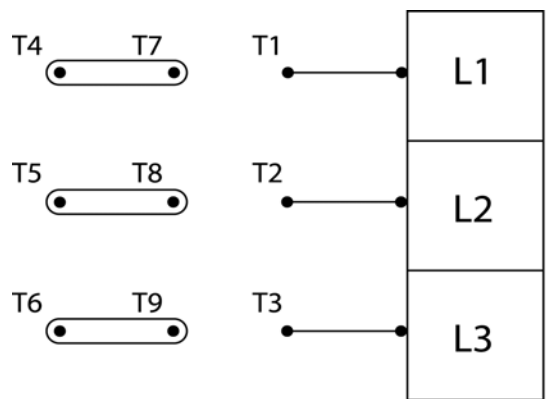

Figure 7 - Three-phase electrical connections: 380-460 V



3.7.2 Connect the pump to your electrical supply



WARNING

Ensure that the electrical installation of the XDS-C pump conforms with your local and national safety requirements. It must be connected to a suitably fused and protected electrical supply and a suitable earth point.



WARNING

If the pump is to be used on the floor of a work area, position the power lead and the exhaust and inlet hoses with care. Ensure that personnel in the area are aware of any obstructions around the pump.

The electrical supply cable to the 3-phase pump is permanently attached to the pump. Ensure that it is routed such that it cannot be snagged or become a tripping hazard.

- Notes:**
1. To prevent automatic restart of the pump-motor if the electrical supply is restored after an electrical supply failure, connect the pump to the electrical supply through suitable control equipment which must be reset manually after an electrical supply failure.
 2. To maintain compliance with CSA (Canadian Standards Association) standards, you must incorporate a switch or circuit breaker in the pump electrical supply. The switch or circuit breaker must be close to the pump and easily accessible, and must be clearly marked to identify that it is the electrical supply disconnection device for the pump.

We recommend that you connect the electrical supply to the motor through a starter or circuit breaker which has thermal over-current protection which can be adjusted to suit the current ratings shown in [Table 6](#). The fuse ratings in [Table 6](#) are provided for guidance only. The supplier of your thermal over-current protection device may specify different values to ensure correct operation of the fuse and the over-current protection device.

Note: The following instructions refer to connecting a cable to the terminal block within the terminal box. If the unit is already fitted with a cable, please ignore these instructions but retain them in the event the cable ever needs replacement. It is still necessary to check the direction of rotation.

The diameter of the electrical supply cable should be in the range 7 to 11 mm. The cable must conform in size and colour coding with your local and national electrical installation regulations.

1. Pass the electrical supply cable through the cable-gland and out of the access hole.
2. Use insulated crimped connectors to connect the wires in the cable to the terminals U1, V1, W1 and earth in the terminal-box as shown in [Figures 6](#) and [7](#). Ensure connections are made using plain washer, spring washer and nut, in that order.
3. Refit the access plate.
4. Tighten the strain-relief nut on the cable-gland.

3.7.3 Check the direction of rotation

CAUTION

Ensure that the pump motor rotates in the correct direction. If it does not, the pump and your vacuum system can become pressurised.

1. Unscrew the 3 retaining screws and remove the plastic cover in the centre of the motor back plate.
2. Switch on the electrical supply to the motor for a few seconds.

3. Check that the screw on the back of the motor rotates in the correct direction, shown by the arrow on the motor.
4. If the direction of rotation is incorrect, switch off the electrical supply and isolate the pump from the electrical supply. Disassemble the plug and switch the positions of the black wires.

3.8 Inlet and outlet connections



WARNING

Connect the exhaust to a suitable treatment plant to prevent the discharge of dangerous gases and vapours to the surrounding atmosphere.

Before you connect the pump to your vacuum system, fit the centring ring and inlet strainer (supplied with the pump) to the pump inlet port. Ensure that debris does not get into your pump when you install it.

Take note of the following information when you connect the pump to your vacuum system. Refer to [Section 7](#) for details of the accessories mentioned below. Use standard DN25NW fittings (not supplied) when you connect the pump.

For maximum pumping speeds, ensure that the pipeline connected to the pump inlet is as short as possible and has an internal diameter of 25 mm or larger.

- Support the vacuum pipeline to prevent loading of the coupling joints.
- If necessary, incorporate flexible pipeline in your system to reduce the transmission of vibration and to prevent loading of the coupling joints. If you use flexible bellows, you must ensure that you use bellows which have a maximum pressure rating which is greater than the highest pressure that can be generated in your system.
- In some applications e.g. when backing a turbomolecular pump, we recommend that you incorporate an inlet isolation valve in the pipeline from the vacuum system to the pump, so that you can isolate the vacuum system from the pump when it is switched off.
- Ensure that the sealing surfaces are clean and scratch-free.

We recommend that you use an exhaust extraction system suitable for use with all of the process gases you will pump. Ensure that the exhaust extraction system cannot become blocked or obstructed when the pump is operating. Use a catchpot on the exhaust to prevent the drainage of contaminated condensation back into the pump.

A small amount of tip seal wear product may collect in the exhaust duct of the pump. The dust may be blown out with the initial burst of air after the pump has been vented. This is quite common and the amount of dust seen will reduce over time.

CAUTION

At high temperature (in excess of 250 °C) tip seal wear product will begin to decompose, giving rise to gaseous fumes which can produce unpleasant symptoms.

3.9 Leak test the system

Leak test the system and seal any leaks found after you have installed the XDS-C pump, to prevent leakage of any substances out of the system and leakage of air into the system.

This page has been intentionally left blank.

4 Operation

4.1 Gas-ballast control

You can use the gas-ballast control to optimise the performance of the dry pump for your application. The performance characteristics of the pump with the different ballast settings are shown in [Table 2](#). You can change the position of the gas-ballast control when the pump is off or when the pump is operating.

Use the gas-ballast control to change the amount of air introduced into the low vacuum stages of the pump. Use of gas-ballast will prevent the condensation of vapours in the pump; the condensates would contaminate the pump. You can turn the gas-ballast control to select one of the three positions, as follows:

To close the gas-ballast, turn the control to position '0'. Use this setting:

- to achieve ultimate vacuum
- to pump dry gases.

To select low flow gas-ballast, turn the control to position 'I'. Use this setting:

- to pump condensable vapours
- to dilute process gases if required.

To select high flow gas-ballast, turn the control to position 'II'. Use this setting:

- to pump high concentrations of condensable vapours
- to dilute process gases if required
- to clear excess vapours after processing.

4.2 Start up procedure



WARNING

Ensure that your system design does not allow the exhaust pipeline to become blocked.

CAUTION

A fine dust may be emitted from the exhaust of the scroll pump during start up, particularly when the pump is new or if new tip seals are fitted. Refer to [Section 5.6](#) for further information when fitting new tip seals.

Use the procedure below to start up the pump:

1. Ensure that any vacuum system isolation valve is closed.
2. Switch on the electrical supply to the pump, using the on / off switch on the motor.
3. Open any vacuum system isolation valve.

4.3 To achieve ultimate vacuum

To close the gas-ballast, turn the control to position '0'. Use this setting in order to achieve the best possible vacuum. If the pump has been used to pump condensable vapours or is to pump a large chamber that has been exposed to atmospheric air (water vapour), it may be necessary to run for at least an hour on high flow gas-ballast 'II'.

4.4 To pump condensable vapours

Use gas-ballast (ballast knob set to I or II) when there is a significant proportion of condensable vapours in the process gases. The pump should be up to full operating temperature prior to exposure to condensable vapours.

4.5 Implication of ATEX directive

4.5.1 Introduction

This equipment is designed to meet the requirements of Group II Category 3 equipment in accordance with Directive 94/9/EC of the European Parliament and the Council of 23rd March 1994 on the approximation of the laws of the Member States concerning equipment and protective systems intended for use in potentially explosive atmospheres. (The ATEX Directive)

The ATEX Category 3 applies in respect of potential ignition sources internal to the equipment. An ATEX Category has not been assigned in respect of potential ignition sources on the outside of the equipment as the equipment has not been designed for use where there is an external potentially explosive atmosphere.

There is no potential source of ignition within the pump during normal operation but there may be potential sources of ignition under conditions of predicted and rare malfunction as defined in the Directive. Accordingly, although the pump is designed to pump flammable materials and mixtures, operating procedures should ensure that under all normal and reasonably predicted conditions, these materials and mixtures are not within explosive limits. Category 3 is considered appropriate for the avoidance of ignition in the case of a rare malfunction which allows flammable materials or mixtures to pass through the pump while within their explosive limits.

4.5.2 Flammable/pyrophoric materials



WARNING

The following precautions and actions must be obeyed to ensure gas being pumped stays out of the flammable range.

When flammable or pyrophoric materials are present within the equipment you must:

- Not allow air to enter the equipment
- Ensure the system is leak tight.
- Use an inert gas purge (for example, a nitrogen purge) to dilute any flammable gases or vapours entering the pump inlet, and/or use an inert gas purge to reduce the concentration of flammable gases or vapours in the pump and in the exhaust pipeline to less than one quarter of the gases' published Lower Explosive Limits (LEL).
- Use an inert gas purge in to the pump gas ballast connection to prevent the condensation of flammable vapours within the pump mechanism and exhaust pipeline.

4.5.3 Gas purges



WARNING

If you use inert gas purge to dilute dangerous gases to a safe level, ensure that the XDS pump is shut down if an inert gas supply fails.



WARNING

You must obey the instructions and take note of the precautions given below, to ensure that pumped gases do not enter their flammable ranges.

Switch on the inert gas purge to remove air from the pump and the exhaust pipeline before the process starts. Switch off the purge flow at the end of the process only after remaining flammable gases or vapours have been purged from the pump and exhaust pipeline.

If liquids that produce flammable vapours could be present in the pump foreline then the inert gas purge to the XDS pump should be left on all the time this liquid is present. Flammable liquids could be present in the foreline as a result of condensation or may be carried over from the process.

When calculating the flow rate of inert gas required for dilution, consider the maximum flow rate for the flammable gases/vapours that could occur. For example, if a mass flow controller is being used to supply flammable gases to the process, you should assume a flow rate for flammable gases that could arise if the mass flow controller is fully open.

Continually measure the inert gas purge flow rate: if the flow rate falls below the required, you must stop the flow of flammable gases or vapours into the pump.

Note: We recommend you obtain and read Vacuum Pump and Vacuum System Safety (publication number P300-20-000), available from Edwards or your supplier.

4.6 Shut down

Use the procedure below to shut down the pump:

1. If shutting the pump down prior to a period of storage, remove any process gases by running on high flow gas-ballast.
2. Close the vacuum system isolation valve to prevent suckback into the vacuum system (where fitted).
3. Switch off the pump using the on/off switch on the motor.

This page has been intentionally left blank.

5 Maintenance

5.1 Safety information



WARNING

Obey the safety instructions given below and take note of appropriate precautions. If you do not, you can cause injury to people and damage to equipment.

The XDS-C pump is designed to require little user maintenance. Observe the following guidelines when carrying out maintenance on your pump:

- Ensure that maintenance is done by a suitably trained and supervised technician. Obey your local and national safety requirements.
- Ensure that the maintenance technician is familiar with the safety procedures which relate to the products processed by the pumping system.
- Check that all the required parts are available and are of the correct type before you start work.
- Isolate the pump and other components from the electrical supply so that they cannot be operated accidentally.
- Allow the pump to cool (so that it is at a safe temperature for skin contact) before you start maintenance work. Make sure that the pump is switched off in case the thermal overload device restarts the pump.
- Do not re-use internal O-rings.
- The pump will be contaminated with the process chemicals that have been pumped during operation. Ensure that the pump is decontaminated before maintenance and that you take adequate precautions to protect people from the effects of dangerous substances if contamination has occurred.
- Do not touch or inhale the thermal breakdown products of fluorinated materials which may be present in the pump if the pump has been heated to 260 °C and above. Fluorinated materials are safe in normal use but can decompose into very dangerous substances (which may include hydrofluoric acid) if they are heated to 260 °C and above. The pump may have overheated if it was misused or if it was in a fire. Health and Safety Data sheets for fluorinated materials used in the pump are available on request: contact your supplier or Edwards.

5.2 Maintenance plan

More frequent maintenance may be required if the pump is used to pump aggressive gases and vapours, such as solvents, organic substances and acids, or if the pump is operated continuously at the higher end of its operating temperature, refer to [Section 2.1](#). If necessary, adjust the maintenance plan according to your experience.

Table 8 - Maintenance plan

Operation	Frequency	Refer to Section
Inspect and clean inlet strainer	Annually	5.3
Inspect and clean the gas-ballast control	Annually	5.4
Clean the external fan cover	Annually	5.5
Replace the tip seals and exhaust valve	Annually or as required	5.6
Test the motor condition	15000 hours	5.7
Replace the bearings	35000 hours	contact Edwards

5.3 Inspect and clean the inlet strainer

Whenever you disconnect the pump from your vacuum system, we recommend that you:

- Remove any debris trapped by the inlet strainer (in the inlet-port).
 - Inspect the inlet strainer and if necessary, clean it with a cleaning solution suitable for the substances pumped. Refit the inlet strainer before you reconnect the pump to your vacuum system.
1. Refer to [Figure 8](#). Disconnect your vacuum system from the pump inlet-port (3) and remove the centring-ring and strainer assembly (1) and the O-ring (2). Inspect the centring-ring and the O-ring. If they are clean, continue at Step 5. If they are not clean, continue at Step 2.
 2. Remove the O-ring (2) from the centring-ring and strainer assembly (1). Do not allow the O-ring to come into contact with the cleaning solution.
 3. Wash the centring-ring and strainer assembly in a suitable cleaning solution and allow it to dry.
 4. If necessary, wipe the O-ring with a clean, dry, lint-free cloth.
 5. Refit the centring-ring and strainer assembly and the O-ring to the inlet-port. Refit your vacuum system to the pump inlet-port.

Figure 8 - Inlet strainer assembly

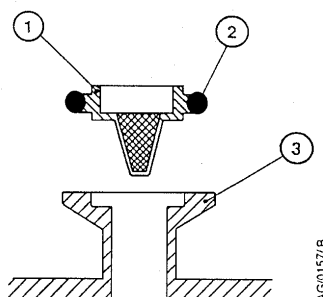

1. Centring ring and strainer
2. O-ring
3. Pump inlet-port

5.4 Inspect and clean the gas-ballast control

The gas-ballast filter element is retained in its seating with adhesive; do not try to remove it.

1. Refer to [Figure 9](#). Turn the gas-ballast control to the high flow position (II).
2. Push the control down against the compression spring as far as it will go, then turn the control anti-clockwise slightly to release the bayonet lugs and remove the control.
3. If necessary, wipe the control with a clean, dry, lint-free cloth and ensure that the air-hole is not blocked.
4. Refit the control into the gas-ballast inlet and ensure that the compression spring locates correctly between the bayonet lugs.
5. Push the control down as far as it will go and then turn the control clockwise slightly until the bayonet lugs engage correctly.
6. Reset the gas-ballast control to the required position.

Figure 9 - Gas-ballast control assembly

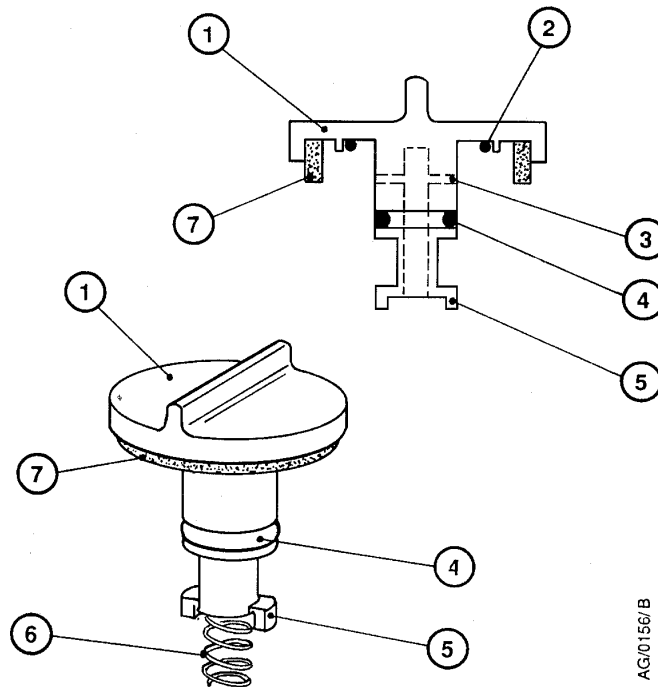

AG/0156/B

- 1. Gas-ballast control
- 2. O-ring
- 3. Air-hole
- 4. O-ring
- 5. Bayonet-lugs
- 6. Compression spring
- 7. Filter element

5.5 Clean the external fan cover

If the fan cover and pump body are not kept clean, the air flow over the pump can be restricted and the pump may overheat.

1. Switch off the pump and disconnect it from the electrical supply.
2. Use a dry cloth and a soft brush to remove dirt and deposits from the fan cover and pump body.

5.6 Replace the tip seals

Refer to Instruction Manual A726-01-840 for instructions on how to replace the tip seals.

5.7 Test the motor condition

Test the earth continuity and the insulation resistance of the pump motor, in accordance with local regulations for the periodic testing of electrical equipment.

The motors of the single-phase XDS-C pumps comply with EN 61010. We recommend that, to maintain compliance with EN 61010, the earth continuity is less than 0.1 Ω and the insulation resistance is greater than 10 M Ω .

If the motor fails these tests, you must contact your supplier or Edwards.

5.8 Fault-finding

5.8.1 The pump has failed to start

- The pump is not connected to the electrical supply (e.g. blown fuse, etc).
- The electrical supply voltage does not match that for which the motor has been configured
- The motor is faulty
- Thermal overload has tripped the pump.

5.8.2 The pump has failed to achieve the required performance

- There is a leak in your vacuum system
- Your pressure measurement technique or gauge head is unsuitable or gives an incorrect indication of pressure
- Your vacuum fittings are dirty or damaged
- The inlet strainer is blocked
- There is a blockage in the exhaust line
- The pump contains traces of process vapours
- The pump is outside the specified range of operating conditions
- The gas-ballast control is not properly closed
- The tip seals need replacing.
- If the electrical supply voltage is more than 10% below the lowest voltage specified on the voltage indicator, the pump may operate yielding a degraded vacuum performance.

5.8.3 The pump is noisy

- The bearings are worn
- The pump is contaminated with solid particles

5.8.4 The pump surface temperature is above 100 °C

- The ambient temperature is too high
- The cooling air supply is insufficient or is too hot
- The electrical supply voltage is too high
- The process gas is too hot
- The fan is not working.

5.8.5 The pumping speed is poor

- The connecting pipelines are too small in diameter
- The connecting pipelines are too long
- The inlet strainer is blocked
- There is a blockage in the exhaust line.

6 Storage and Disposal

6.1 Storage

Use the following procedure to store the pump:

1. Shut down the pump as described in [Section 4](#).
2. Disconnect the pump from the electrical supply.
3. Purge your vacuum system and the pump with dry nitrogen and disconnect the pump from your vacuum system.
4. Place and secure protective covers over the inlet and outlet ports.
5. Store the pump in cool, dry conditions until required for use. When required, prepare and install the pump as described in [Section 3](#).

6.2 Disposal

Dispose of the pump and any components from it safely in accordance with all local and national safety and environmental requirements.

Particular care must be taken with components which have been contaminated with dangerous process substances.

Do not incinerate fluoroelastomer seals and O-rings.

This page has been intentionally left blank.

7 Spares and Accessories

7.1 Introduction

Edwards products, spares and accessories are available from Edwards companies in Belgium, Brazil, Canada, France, Germany, Hong Kong, Italy, Japan, Korea, Switzerland, UK, USA and a worldwide network of distributors. The majority of these centres employ Service Engineers who have undergone comprehensive Edwards training courses.

Order spare parts and accessories from your nearest Edwards company or distributor. When you order, state for each part required:

- Model and item number of your equipment
- Serial number
- Item number and description of part.

7.2 Spares

Product	Item number
Tip seal kit XDS5-C/10-C	A726-01-824

7.3 Accessories

7.3.1 Solenoid operated pipeline valve

Fit the pipeline valve between your vacuum system (refer to Table 9) and the pump inlet to provide additional system protection when the pump is switched off.

Table 9 - Solenoid operated pipeline valve

Product	Electrical Supply	Item Number	
		Aluminium	Steel
PV25EK Valve	220-240 V 50/60 Hz	C413-01-000	C413-02-000
PV25EK Valve	110-127 V 50/60 Hz	C413-03-000	C413-04-000

7.3.2 Gas-ballast adaptor

There are two gas-ballast adaptor kits which can be used depending on application requirements:

Gas-ballast adaptor kit (use with EB valve)	A505-02-000
Gas-ballast adaptor kit (controlled flow through orifice)	A506-26-801

7.3.3 Vibration isolators

Vibration isolators reduce vibration and noise when the pump is floor or frame mounted and help to reduce strain when the mounting area is uneven.

Vibration isolators (pack of 4)	A248-01-404
---------------------------------	-------------

Refer to Instruction Manual A248-01-880 for fitting instructions.

7.3.4 Exhaust nozzle kit

The exhaust nozzle screws into the outlet flange. Use the exhaust nozzle to connect the pump outlet to the 12 mm internal diameter plastic hose.

Exhaust nozzle kit A505-09-000

7.3.5 XDS silencer

The XDS silencer can be used to reduce exhaust noise during pump down and gas ballast operation.

XDS Silencer A505-97-000

Index

A

Accessories	29
ATEX directive implications	2

C

Clean the external fan cover	25
Construction	4

D

Description	2
Dimensions	7
Disposal	27

E

Electrical data	8
Electrical installation	
single-phase pumps	12
three-phase pumps	14

F

Fault-finding	26
Flammable/pyrophoric materials	20

G

Gas purges	21
Gas-ballast control	4, 19

I

Inlet and outlet connections	17
Inspect and clean the gas-ballast control	24
Inspect and clean the inlet strainer	24
Installation	11
Introduction	1

L

Leak test the system	17
Legislation and standards	9
Lifting the pump	12
Locate the pump	12

M

Maintenance	23
Maintenance plan	23
Mechanical data	8

N

Noise and vibration data	8
--------------------------------	---

O

Operating and storage conditions	5
Operation	19

P

Performance	5
Performance characteristics	6

R

Replace the tip seals	25
-----------------------------	----

S

Safety	11
Scope and definitions	1
Shut down	21
Single-phase pumps	8
Spares	29
Start up procedure	19
Storage	27
System design considerations	11

T

Technical data	5
Test the motor condition	25
Three-phase pumps	8
To achieve ultimate vacuum	19
To pump condensable vapours	20

U

Unpack and inspect	11
--------------------------	----

This page has been intentionally left blank.