



Technology for Vacuum Systems

Instructions for use



PC 3001 basic

Chemistry pumping unit with speed control

Dear customer,

Your VACUUBRAND diaphragm pumps are designed to provide you with many years of trouble-free service with optimal performance. Our many years of practical experience allow us to provide a wealth of application and safety information. Please read these instructions for use before the initial operation of your pump.

VACUUBRAND diaphragm pumps combine our many years of experience in design, construction and practical operation, with the latest developments in material and manufacturing technology.

Our quality maxim is the "zero defect" principle:

Every diaphragm pump, before leaving our factory, is tested intensively, including an endurance run of 14 hours. Any faults, even those which occur rarely, are identified and can be eliminated immediately.

After completion of the endurance run, every pump is tested, and must achieve specifications before shipment.

We are committed to providing our customers only pumps that meet this high quality standard.

While our pumps cannot eliminate all of your work, we design, manufacture and test them to ensure that they will be an effective and trouble-free tool to assist you in that work.

Yours,

VACUUBRAND GMBH + CO KG

After sales service:

Contact your local dealer or call +49 9342 808-5500.

Trademark index:

VACUU•LAN® (US-Reg.No 3,704,401), VACUU•BUS®, VACUU•CONTROL™, chemistry-HYBRID™, Peltronic®, TURBO•MODE™, VARIO® (US-Reg.No 3,833,788), VARIO-SP™, VACUUBRAND® (US-Reg.No 3,733,388) and also the shown company logos are trademarks of VACUUBRAND GMBH + CO KG in Germany and/or other countries.

DE

Achtung: Die vorliegende Betriebsanleitung ist nicht in allen EU-Sprachen verfügbar. Der Anwender darf die beschriebenen Geräte nur dann in Betrieb nehmen, wenn er die vorliegende Anleitung versteht oder eine fachlich korrekte Übersetzung der vollständigen Anleitung vorliegen hat. Die Betriebsanleitung muss vor Inbetriebnahme der Geräte vollständig gelesen und verstanden werden, und alle geforderten Maßnahmen müssen eingehalten werden.  "Sicherheitshinweise für Vakuumgeräte"

EN

Attention: This manual is not available in all languages of the EU. The user must not operate the device if he does not understand this manual. In this case a technically correct translation of the complete manual has to be available. The manual must be completely read and understood before operation of the device and all required measures must be applied.  "Safety instructions for vacuum equipment"

FR

Attention: Le mode d'emploi présent n'est pas disponible dans toutes les langues d'Union Européenne. L'utilisateur ne doit mettre le dispositif en marche que s'il comprend le mode d'emploi présent ou si une traduction complète et correcte du mode d'emploi est sous ses yeux. Le dispositif ne doit pas être mis en marche avant que le mode d'emploi ait été lu et compris complètement et seulement si le mode d'emploi est observé et tous les mesures demandées sont prises.

 «Avis de sécurité pour des dispositifs à vide»

BG

Внимание: Тези инструкции не са преведени на всички езици от ЕО. Потребителят не бива да работи с уреда, ако не разбира инструкциите за ползване. В този случай е необходимо да бъде предоставен пълен технически превод на инструкциите за ползване. Преди работа с уреда е задължително потребителят да прочете изцяло инструкциите за работа.

 "Указания за безопасност за вакуумни уреди"

CN

注意：该操作手册不提供所有的语言版本。操作者在没有理解手册之前，不能操作该设备。在这种情况下，需要有一个整个操作手册技术上正确的翻译。在操作该设备前，必须完全阅读并理解该操作手册，必须实施所有需要的测量。

 真空设备的安全信息

CZ

Upozornění :Tento návod k použití není k dispozici ve všech jazycích Evropské unie. Uživatel není oprávněn požit přístroj pokud nerozumí tomuto návodu. V takovém případě je nutno zajistit technicky korektní překlad manuálu do češtiny. Návod musí být uživatelem prostudován a uživatel mu musí plně porozumět před tím než začne přístroj používat. Uživatel musí dodržet všechna příslušná a požadovaná opatření.  "Bezpečnostní upozornění pro vakuové přístroje".

DA

Bemærk: Denne manual foreligger ikke på alle EU sprog. Brugeren må ikke betjene apparatet hvis manualen ikke er forstået. I det tilfælde skal en teknisk korrekt oversættelse af hele manual stilles til rådighed. Manual skal være gennemlæst og forstået før apparatet betjenes og alle nødvendige forholdsregler skal tages.

 »Sikkerhedsregler for vakuumdstyr«

EE

Tähelepanu! Käesolev kasutusjuhend ei ole kõigis EL keeltes saadaval. Kasutaja ei tohi seadet käsitseda, kui ta ei saa kasutusjuhendist aru. Sel juhul peab saadaval olema kogu kasutusjuhendi tehniliselt korrektne tõlge. Enne seadme kasutamist tuleb kogu juhend läbi lugeda, see peab olema arusaadav ning kõik nõutud meetmed peavad olema rakendatud.  "Ohutusnõuded vaakumseadmetele"

ES

Atención: Este manual no está disponible en todos los idiomas de UE. El usuario no debe manejar el instrumento si no entiende este manual. En este caso se debe disponer de una traducción técnicamente correcta del manual completo. El manual debe ser leído y entendido completamente y deben aplicarse todas las medidas de seguridad antes de manejar el instrumento.  "Notas sobre la seguridad para equipos de vacío"

FI

Huomio: Tämä käyttöohje ei ole saatavilla kaikilla EU: n kielillä. Käyttäjä ei saa käyttää laitetta, jos hän ei ymmärrä tätä ohjekirjaa. Tässä tapauksessa on saatavilla oltava teknisesti oikein tehty ja täydellinen ohjekirjan käännös. Ennen laitteen käyttöä on ohjekirja luettava ja ymmärrettävä kokonaan sekä suoritettava kaikki tarvittavat valmistelut ja muut toimenpiteet.  "Vakuumlaitteen turvallisuustiedot"

GR

Προσοχή! : Οι οδηγίες αυτές δεν είναι διαθέσιμες σε όλες τις γλώσσες της Ευρωπαϊκής Ένωσης. Ο χρήστης δεν πρέπει να θέσει σε λειτουργία την συσκευή αν δεν κατανοήσει πλήρως τις οδηγίες αυτές. Σε τέτοια περίπτωση ο χρήστης πρέπει να προμηθευτεί ακριβή μετάφραση του βιβλίου οδηγιών. Ο χρήστης πρέπει να διαβάσει και να κατανοήσει πλήρως τις οδηγίες χρήσης και να λάβει όλα τα απαραίτητα μέτρα πριν θέσει σε λειτουργία την συσκευή.  "Υποδείξεις ασφάλειας για αντλίες κενού"

HR

Pažnja: ove upute ne postoje na svim jezicima Europske Unije. Korisnik nemora raditi sa aparatom ako ne razumije ove upute. U tom slučaju tehnicki ispravni prijevod cijelih uputstava mora biti na raspolaganju. Uputstva moraju biti cijela procitana i razumljiva prije rada sa aparatom i sve zahtijevane mjere moraju biti primjenjene.

 "Sigurnosne napomene za vakuumske uređaje"

HU

Figyelem! Ez a kezelési utasítás nem áll rendelkezésre az EU összes nyelvén. Ha a felhasználó nem érti jelen használati utasítás szövegét, nem üzemeltetheti a készüléket. Ez esetben a teljes gépkönyv fordításáról gondoskodni kell. Üzembe helyezés előtt a kezelőnek végig kell olvasnia, meg kell értenie azt, továbbá az üzemeltetéshez szükséges összes mérést el kell végeznie.  "A vákuum-készülékekkel kapcsolatos biztonsági tudnivalók"

IT

Attenzione: Questo manuale non è disponibile in tutte le lingue della Comunità Europea (CE). L'utilizzatore non deve operare con lo strumento se non comprende questo manuale. In questo caso deve essere resa disponibile una traduzione tecnicamente corretta del manuale completo. Il manuale deve essere completamente letto e compreso prima di operare con lo strumento e devono essere applicati tutti gli accorgimenti richiesti.  "Istruzioni di sicurezza per apparecchi a vuoto"

JP

注意：この取扱説明書はすべての言語で利用可能ではありません。もしこの取扱説明書を理解できないならば、ユーザーは装置を操作してはなりません。この場合、技術的に正しい翻訳がなされた完全なマニュアルを用意しなければなりません。装置を作動する前にマニュアルを完全に読み、そして理解されなくてはなりません。そして、すべての要求される対策を講じなければなりません。

 真空装置を安全に取り扱うために

KR

주의: 이 매뉴얼은 모든 언어로 번역되지 않습니다. 만약 이 매뉴얼의 내용을 충분히 인지하지 못했다면 기기를 작동하지 마십시오. 매뉴얼의 내용을 기술적으로 정확하게 번역한 경우에 이용하십시오. 기기를 사용하기 전에 이 매뉴얼을 충분히 읽고 이해하고 모든 요구되는 사항들을 적용해야 합니다.

 진공 장비에 대한 안전 정보

LT

Dėmesio: šis vadovas nėra pateikiamas visomis ES kalbomis. Naudotojui draudžiama eksploatuoti įtaisą, jeigu jis nesupranta šio vadovo. Tokiu atveju reikia turėti viso vadovo techniškai taisyklingą vertimą. Vadovą būtina visą perskaityti ir suprasti pateikiamas instrukcijas prieš pradėdant eksploatuoti įtaisą, bei imtis visų reikiamų priemonių.  "Vakuuminės įrangos saugos informacija"

LV

Uzmanību: Lietotāja instrukcija nav pieejama visās ES valodās. Lietotājs nedrīkst lietot iekārtu, ja viņš nesaprot lietotāja instrukcijā rakstīto. Šādā gadījumā, ir nepieciešams nodrošināt tehniski pareizu visas lietotāja instrukcijas tulkojumu. Pirms sākt lietot iekārtu, un, lai izpildītu visas nepieciešamās prasības, iekārtas lietotāja instrukcija ir pilnībā jāizlasa un jāsaprot.  "Vakuuma iekārtu drošības noteikumi"

NL

Attentie: Deze gebruiksaanwijzing is niet in alle talen van de EU verkrijgbaar. De gebruiker moet niet met dit apparaat gaan werken als voor hem/haar de gebruiksaanwijzing niet voldoende duidelijk is. Bij gebruik van deze apparatuur is het noodzakelijk een technisch correcte vertaling van de complete gebruiksaanwijzing te hebben. Voor het in gebruik nemen van het apparaat moet de gebruiksaanwijzing volledig gelezen en duidelijk zijn en dienen alle benodigde maatregelen te zijn genomen.  "Veiligheidsvoorschriften voor vacuümapparaten"

PL

Uwaga!! Ta instrukcja nie jest dostępna we wszystkich językach Unii Europejskiej. Użytkownik nie może rozpocząć pracy z urządzeniem dopóki nie przeczytał instrukcji i nie jest pewien wszystkich informacji w niej zawartych. Instrukcja musi być w całości przeczytana i zrozumiana przed podjęciem pracy z urządzeniem oraz należy podjąć wszystkie niezbędne kroki związane z prawidłowym użytkowaniem.

 "Wskazówki bezpieczeństwa do urządzeń próżniowych"

PT

Atenção: Este manual não está disponível em todas as línguas da UE. O usuário não deve utilizar o dispositivo, se não entender este manual. Neste caso, uma tradução tecnicamente correta do manual completo tem de estar disponível. O manual deve ser lido e entendido completamente antes da utilização do equipamento e todas as medidas necessárias devem ser aplicadas.  "Informação de Segurança para Equipamento que funciona a Vácuo"

RO

Atentie: Acest manual nu este disponibil in toate limbile EU. Utilizatorul nu trebuie sa lucreze cu aparatul daca nu intelege manualul. Astfel, va fi disponibile o traducere corecta si completa a manualului. Manualul trebuie citit si inteles in intregime inainte de a lucra cu aparatul si a luat toate masurile care se impun.

 "Instrucțiuni de siguranță pentru aparatele de vidare"

RU

Внимание: Эта инструкция по эксплуатации не имеется на всех языках. Потребителю не дозволено эксплуатировать данный прибор, если он не понимает эту инструкцию. В этом случае нужен технически правильный перевод полной инструкции. Прежде чем использовать этот прибор, необходимо полностью прочитать и понять эту инструкцию и принять все необходимые меры.  "Указания по технике безопасности при работе с вакуумными устройствами"

SE

Varning: Denna instruktion är inte tillgänglig på alla språk inom EU. Användaren får inte starta utrustningen om hon/han inte förstår denna instruktion. Om så är fallet måste en tekniskt korrekt instruktion göras tillgänglig. Instruktionen måste läsas och förstås helt före utrustningen tas i drift och nödvändiga åtgärder göres.

 "Säkerhetsinformation för vakuumutrustning"

SI

Pozor: Ta navodila niso na voljo v vseh jezikih EU. Uporabnik ne sme upravljati z napravo, če ne razume teh navodil. V primeru nerazumljivosti mora biti na voljo tehnično pravilen prevod. Navodila se morajo prebrati in razumeti pred uporaba naprave, opravljene pa moraja biti tudi vse potrebne meritve.

 "Varnostni nasveti za vakuumske naprave"

SK

Upozornenie: Tento manuál nie je k dispozícii vo všetkých jazykoch EÚ. Užívateľ nesmie obsluhovať zariadenie, pokiaľ nerozumie tomuto manuálu. V takomto prípade musí byť k dispozícii technicky správny preklad celého manuálu. Pred obsluhou zariadenia je potrebné si prečítať celý manuál a porozumieť mu, a musia byť prijaté všetky opatrenia.  "Bezpečnostné pokyny pre vákuové zariadenia"

TR

Dikkat : Bu kullanım kitabı, tüm dillerde mevcut değildir. Kullanıcı, bu kullanım kitabını anlayamadıysa cihazı çalıştırmamalıdır. Bu durumda, komple kullanım kitabının, teknik olarak düzgün çevirisinin bulunması gerekir. Cihazın çalıştırılmasından önce kullanım kitabının komple okunması ve anlaşılması ve tüm gerekli ölçümlerin uygulanması gerekir.  "Vakumlu cihazlar için güvenlik uyarıları"

Contents

| | |
|---|-----------|
| Safety information! | 9 |
| Important information! | 9 |
| General information..... | 11 |
| Intended use..... | 11 |
| Setting up and installing the equipment | 12 |
| Ambient conditions | 14 |
| Operating conditions | 15 |
| Safety during operation | 16 |
| Maintenance and repair..... | 19 |
| ⊕ Important information: Equipment marking (ATEX)..... | 21 |
| Technical data | 23 |
| Gas inlet temperatures | 24 |
| Wetted parts | 25 |
| Abbreviations..... | 25 |
| Pump parts | 26 |
| Upgrade kits for PC 3001 basic..... | 27 |
| Use and operation | 28 |
| Installing a pump in a vacuum system | 28 |
| During operation..... | 30 |
| Important notes regarding the use of gas ballast | 31 |
| Shutdown & storage..... | 32 |
| Accessories | 34 |
| Troubleshooting | 35 |
| Replacing diaphragms and valves | 37 |
| Cleaning and inspecting the pump heads | 39 |
| Disassembling the housing cover at the inlet side | 39 |
| Replacing the diaphragm | 41 |
| Assembling the housing cover at the inlet side | 44 |
| Disassembling the housing cover at the side of the ON/OFF switch | 44 |
| Assembling the housing cover at the side of the ON/OFF switch | 45 |
| Assembling the fittings..... | 46 |
| Notes on return to the factory | 48 |
| Warranty | 51 |
| Health and safety clearance form | 52 |
| EC Declaration of Conformity of the Machinery | 53 |

Safety information!

Important information!

WARNING

- ☞ Keep this manual complete and accessible to personnel at all times!
- ☞ Read this manual carefully before installing or operating the equipment. Observe the instructions contained in this manual.

- ☞ Do not modify the equipment without authorization.

NOTICE

This manual is an integral part of the equipment described therein. It describes the safe and proper use of the vacuum pump.

Make operating personnel aware of dangers arising from the pump and the pumped substances.

VACUUBRAND disclaims any liability for inappropriate use of these pumps and for damage from failure to follow instructions contained in this manual.

This manual is only to be used and distributed in its complete and original form. It is strictly the users' responsibility to check carefully the validity of this manual with respect to his product.

Manual-no.: 999198 / 04/01/2014

The following signal word panels and safety symbols are used throughout this manual:



This is the safety alert symbol. It is used to alert you to potential personal injury hazards. Obey all safety messages that follow this symbol to avoid possible injury and death.



➔ DANGER indicates a hazardous situation which, if not avoided, will result in death or serious injury.



☞ WARNING indicates a hazardous situation which, if not avoided, could result in death or serious injury.



• CAUTION indicates a hazardous situation which, if not avoided, could result in minor or moderate injury.



NOTICE is used to address practices not related to personal injury.



Caution! Hot surface!



Disconnect equipment from AC power.



Dispose of electronic equipment according to regulations.



Formatting used in this manual:

Note: The signal word panels in all sections of this manual always refer to all paragraphs of the same format (➔ / ☞ / • / plain text) following each signal word panel.

The document "Safety information for vacuum equipment" is part of this manual! Read the "Safety information for vacuum equipment" and observe the instructions contained therein!

General information

NOTICE

Remove all packing material from the packing box. Remove the product from its packing-box and retain all packaging until the equipment is inspected and tested. Remove the protective caps from the inlet and outlet ports and retain for future use. Inspect the equipment promptly and carefully.

If the equipment is damaged, notify the supplier and the carrier in writing within three days. Retain all packing material for inspection. State the item number of the product together with the order number and the supplier's invoice number. Failure to check and give notice of damage will void any and all warranty claims for those deficiencies.

Replace the protective caps if the equipment is not used immediately. Store the equipment in dry and non-corrosive conditions (see also „Technical data“, pg. 23).

WARNING

☞ **Do not use any damaged equipment.**

CAUTION

- Use the mounted handle when moving the pumping unit.

Intended use

WARNING

☞ Do not use the pump or any system parts on humans or animals.

☞ Ensure that the individual components are only connected, combined and operated according to their design and as indicated in the instructions for use. Use only **original manufacturer's spare parts and accessories**. Otherwise the safety and performance of the equipment, as well as the electromagnetic compatibility of the equipment might be reduced.

The CE mark or the cTÜVus mark may be voided if not using original manufacturer's spare parts.

- ☞ Comply with all notes on correct vacuum and electrical connections; see section „Use and operation“, pg. 28.
- ☞ Do not use the pump to generate pressure.
- ☞ The pumps are designed for **ambient temperatures** during operation between +50°F and +104°F (+10°C and +40°C). Periodically check maximum temperatures if installing the pump in a cabinet or a housing. Make sure ventilation is adequate to maintain recommended operating temperature. Install an external automatic ventilation system if necessary. If pumping hot process gases, make sure that the maximum permitted gas inlet temperature is not exceeded. The maximum permitted gas inlet temperature depends on several parameters like inlet pressure and ambient temperature (see „Technical data“, pg. 23).
- ☞ Particles and dust must not enter the pump.
- ☞ Do not pump liquids.

CAUTION

- Ensure that the pump, and any accessories in the flow path are chemically resistant to the pumped substances prior to operation.

NOTICE

Use the equipment **only as intended**, that is, for generation and control of vacuum in vessels designed for that purpose. Any other use will automatically invalidate all warranty and liability claims. Remain aware of safety and risks.

Setting up and installing the equipment

DANGER

- ➔ Equipment must be connected only to a **suitable electrical supply** and a suitable ground point. As such, the plug must be plugged into an outlet that is properly grounded. Failure to connect the motor to ground may result in deadly electrical shock.

The supply cable may be fitted with a molded European IEC plug or a plug suitable for your local electrical supply. The cable contains wires color coded as follows: green or green and yellow: ground; blue or white: neutral; brown or black: hot.

⚠ WARNING

- ☞ Due to the high compression ratio, the pump may generate overpressure at the outlet. Check pressure compatibility with system components (e.g., exhaust pipeline or exhaust valve) at the outlet.
- ☞ Do not permit any **uncontrolled pressurizing**. Make sure that the exhaust pipeline cannot become blocked. If there is an exhaust isolation valve, make sure that you cannot operate the equipment with the valve closed to avoid a **risk of bursting!**
- ☞ Keep the electrical power cord away from heated surfaces.

⚠ CAUTION

- Provide a firm, level platform for the equipment. Check that the system which you are going to evacuate is mechanically stable. Check that all fittings are secure. Ensure a stable position of the pump without any mechanical contact other than the pump feet.
- Comply with **maximum permissible pressures** at inlet and outlet and with **maximum permissible pressure differences** between inlet and outlet. See section „Technical data“, pg. 23. Do not operate the pump with overpressure at the inlet.
- Avoid overpressure of more than 17.5 psi absolute (1.2 bar absolute) in the event that inert gas is connected to the pump, to the gas ballast or to a venting valve.
- **Note:** Flexible elements will shrink when evacuated.
- Connect hoses gas tight at inlet and outlet of the pump.
- Ensure that no foreign objects can be drawn into the pump.

- Check the power source and the pump's rating plate to be sure that the power source and the equipment match in voltage, phase, and frequency.

NOTICE

Make sure ventilation is adequate to maintain recommended operating temperature. Keep a minimum distance of 2 in (5 cm) between the cooling fan and surrounding items (e.g., housing, walls, etc.), or else install an external automatic ventilation system. Clean ventilation slots if necessary to avoid a reduction of ventilation.

Do not place the pumping unit on soft surfaces (e.g., rubber foam) during operation. This may reduce or block the electronics' air supply. Do not cover the pumping unit.

Use only hoses at the inlet and outlet of the pump with an inner diameter at least as large as the diameter of the pump's tubing (to avoid overpressure at the outlet, and reduction of pumping speed at the inlet).

Allow the equipment to equilibrate to ambient temperature if you bring it from cold environment into a room prior to operation. Notice if there is water condensation on cold surfaces.

Comply with all **applicable and relevant safety requirements** (regulations and guidelines). **Implement the required actions and adopt suitable safety measures.**

Ambient conditions

⚠ DANGER

- ➔ Do not reach for this product if it has fallen into liquid. There is a risk of deadly electrical shock. Unplug the system immediately.

⚠ WARNING

- ☞ Do not use this product in an area where it can fall or be pulled into water or other liquids.

CAUTION

- Adopt suitable measures in case of differences from recommended conditions, e.g., using the equipment outdoors, installation in higher altitudes, conductive pollution or external condensation on the pump.
- Do not operate this product near flames.

NOTICE

To the best of our knowledge the equipment is in compliance with the requirements of the applicable EC-directives and harmonized standards (see "Declaration of Conformity") with regard to design, type and model. Directive EN 61010-1 gives in detail the conditions under which the equipment can be operated safely (see also IP degree of protection, „Technical data“, pg. 23).

Operating conditions**DANGER**

- ➔ These pumps are not approved for operation in potentially explosive atmospheres. **Do not operate the pumps in potentially explosive atmospheres.**
- ➔ Pumps **without the "Ex" mark on the rating plate are not approved for the pumping of potentially explosive atmospheres. Do not pump potentially explosive atmospheres** with those pumps.
- ➔ Pumps **bearing the "Ex" mark on their rating plates are approved for the pumping of potentially explosive atmospheres** according to their classification **II 3G IIC T3 X** according to ATEX, but they are **not approved for operation in potentially explosive atmospheres** (see section „Ex Important information: Equipment marking (ATEX)“, pg. 21).
- ➔ The pumps are **not suitable** to pump any of the substances listed below.
Do not pump:
 - **unstable substances**
 - substances which react explosively under **impact** (mechanical stress) without air

- substances which react explosively when being exposed to **elevated temperatures** without air,
- substances subject to **auto-ignition**,
- substances which are **inflammable without air**
- **explosive substances**.

➔ The pumps are **not approved** for operation below ground. **Do not operate** the pump **below ground**.

CAUTION

- **Do not pump** substances which may form **deposits** inside the pump. The pumps are not suitable for pumping substances which may form deposits inside the pump. Deposits and condensate in the pump may lead to increased temperatures even to the point of exceeding the maximum permitted temperatures.
- Check the inlet and outlet of the pump, if there is a danger of forming **deposits** inside the pump, e.g., in the pump chambers (the pump chamber is the part between diaphragm and head cover. See section „Replacing diaphragms and valves“, pg. 37). Inspect the pump chambers regularly and clean if necessary.
- **Consider interactions and chemical reactions of the pumped media.** Ensure that the materials of the pump's wetted parts are compatible with the pumped substances, see section „Technical data“, pg. 23. When changing the substances pumped, we recommend purging the pump with air or inert gas prior to changing the pumped media. Purging the pump will pump out residues and it will reduce the possibility of reactions of the pumped substances with each other and with the pump's materials.

Safety during operation

DANGER

- ➔ Adopt suitable measures to prevent the release of dangerous, toxic, explosive, corrosive, noxious or polluting fluids, vapors and gases. To prevent any emission

of such substances from the pump outlet, install an appropriate collecting and disposal system and take protective action for pump and environment.

- ➔ You must take suitable precautions to prevent any formation of explosive mixtures in the pump chamber or at the outlet of the pump. In case, e.g., of a diaphragm failure, mechanically generated sparks, hot surfaces or static electricity may ignite these mixtures. Use inert gas for gas ballast or venting, if necessary.
- ➔ Drain appropriately or otherwise remove any potentially explosive mixtures at the outlet of the pump, or dilute them to non-explosive concentrations.
- ➔ Never operate this pump if it has a damaged cord or plug.

⚠ WARNING

- ☞ If the pump is not working properly, has been dropped or has fallen into water, contact your pump service provider.
- ☞ Prevent any part of the human body from coming into contact with vacuum.
- ☞ Make sure that the exhaust pipeline cannot become blocked.
- ☞ Comply with applicable regulations when disposing of chemicals. Take into consideration that chemicals may be contaminated. Take adequate precautions to protect people from the effects of dangerous substances (chemicals, thermal decomposition products of fluoroelastomers). Use appropriate protective clothing and safety goggles.
- ☞ Interruption of the pump (e.g., due to power failure), failure of connected components or of parts of the supply, or change in parameters must not be allowed to lead to dangerous conditions. In case of a diaphragm failure or in case of a leak in the manifold, pumped substances might be released into the environment or

into the pump housing or motor.

Comply with all notes regarding proper use of the pumps, as well as operation and maintenance guidance.

- ☞ The residual **leak rate of the equipment** might render possible an exchange of gas, albeit extremely slight, between the environment and the vacuum system. Adopt suitable measures to prevent contamination of the pumped substances or the environment.

CAUTION

- Ensure that no parts of your clothing, hair or fingers can be caught or drawn in at the inlet of the pump. Never insert fingers or drop any other object into the inlet or outlet.
- Pumping at high inlet pressure may lead to overpressure at the gas ballast valve. Pumped gases or condensate might be expelled if the valve is open. If an inert gas supply is connected to the gas ballast, ensure that its inlet pipeline is not contaminated.
- You must take suitable precautions to prevent any dangerous situation from arising if the pump is starting.
- Pay attention to the safety symbol "hot surfaces" on the equipment. Hot parts may cause burns if touched. Adopt suitable measures to prevent any danger arising from hot surfaces or electric sparks. Ensure that hot surfaces of the pump do not cause burns. Provide a suitable contact guard if necessary.



NOTICE

Prevent the backpressure of gases and the backflow of condensates at the outlet.

Provide appropriate protective measures to allow for the possibility of failure and **malfunction**. The protective measures must also allow for the requirements of the respective application.

A temperature sensor at the circuit board protects the motor: Current limitation in case the temperature at the circuit board raises above 158°F (70°C). At temperatures above 185°F (85°C) the pump is switched off. In case of a motor blockage (after 10 start-up attempts) the pump is switched off.

Note: Only manual reset is possible. Disconnect the pump from the power source. Identify and eliminate the cause of failure.

Maintenance and repair

NOTICE

In order to comply with laws (occupational, health and safety regulations, safety at work law and regulations for environmental protection) vacuum pumps, components and measuring instruments can only be returned when certain procedures (see section „Notes on return to the factory“, pg. 48) are followed.

Take advantage of our service seminars, which put special focus on the maintenance and repair of vacuum pumps. For details and for the online "Instructions for repair" manual see www.vacuubrand.com.

In normal use, the lifetime of the diaphragms and valves is typically 15,000 operating hours. Bearings have a typical durability of 40000 h.

! DANGER

➔ **Ensure that the pump cannot be operated accidentally. Never operate the pump if covers or other parts of the pump are disassembled.**



➔ **Switch off the pump. Disconnect the electrical power cord and wait two minutes** before starting maintenance to allow the capacitors to discharge.

➔ **Note:** The pump may be contaminated with process chemicals, which have been pumped during operation.

Ensure that the pump is completely decontaminated before maintenance commences.

⚠ WARNING

- ☞ Take adequate precautions to protect people from the effects of dangerous substances if contamination has occurred. Use appropriate protective clothing, safety goggles and protective gloves.
- ☞ **Wear parts have to be replaced regularly.**
- ☞ **Never operate a defective or damaged pump.**
- ☞ Vent the pump before starting maintenance. Isolate the pump and other components from the vacuum system. Allow sufficient cooling of the pump.

NOTICE

Ensure that **maintenance** is done only by suitably trained and supervised technicians. Ensure that the maintenance technician is familiar with the safety procedures which relate to the products processed by the pumping system. Only dismantle the pump as far as necessary.



 Important information: Equipment marking (ATEX)**VACUUBRAND equipment bearing mark (see rating plate)**

 II 3G IIC T3 X
Internal Atm. only
Tech. File Ref.: VAC-EX01

and

VACUUBRAND equipment bearing mark (see rating plate)

 X see manual

For equipment labelled with „ X see manual“ the following classification according to Directive 94/9/EC (ATEX) is valid:  II 3G IIC T3 X, Internal Atm. only, Tech. File Ref.: VAC-EX01.

The classification II 3G IIC T3 X according to ATEX is only valid for the inner part (wetted part, pumped gas or vapor) of the equipment. The equipment is not suitable for use in external, potentially explosive atmospheres (environment).

The overall category of the equipment depends on the connected components. If the connected components do not comply with the classification of the VACUUBRAND equipment, the specified category of the VACUUBRAND equipment is no longer valid.

Vacuum pumps and vacuum gauges in category 3 are intended for connection to equipment in which during normal operation explosive atmospheres caused by gases, vapors or mists normally don't occur or, if they do occur, are likely to do so only infrequently and for a short period only. Equipment in this category ensures the requisite level of protection during normal operation.

The use of gas ballast or the operation of venting valves is only permitted if thereby explosive atmospheres normally don't occur in the interior of the equipment or, if they do occur, are likely to do so only infrequently and for a short period.

The pumps are marked with "X" (according to EN 13463-1), i.e., restrictions of the operation conditions:

- The equipment is designated for a low degree of mechanical stress and has to be installed in a way so that it cannot be damaged from outside.
Pumping units have to be installed so that they are protected against shocks from the outside and against glass splinters in the event of breakage (implosion).
- The equipment is designated for an ambient and gas inlet temperature during operation of +10 to +40°C. Never exceed these ambient and gas inlet temperatures. If pumping / measuring gases which are not potentially explosive, extended gas inlet temperatures are permissible. See instructions for use, section "Gas inlet temperatures" or "Technical data".

After any intervention at the equipment (e.g., repair / maintenance) the ultimate vacuum of the pump has to be checked. Only if the pump achieves its specified ultimate vacuum is the pump's leak rate low enough to ensure that no explosive atmospheres will occur in the interior of the equipment.

After any intervention at the vacuum sensor, the leak rate of the equipment has to be checked.



Attention: This manual is not available in all languages of the EU. The user must not operate the device if he does not understand this manual. In this case a technically correct translation of the complete manual has to be available. The manual must be completely read and understood before operation of the device. All specified measures must be applied, or else must be replaced by equivalent measures at the user's own risk.

Technical data

| Type | | PC 3001 basic |
|--|----------------------------|---|
| Maximum pumping speed (ISO 21360) | cfm (m ³ /h) | 1.2 (2.0) |
| Ultimate vacuum (absolute) without gas ballast | Torr (mbar) | 1.5 (2) |
| Ultimate vacuum (absolute) with gas ballast | Torr (mbar) | 3 (4) |
| Maximum permissible inlet and outlet pressure (absolute) | psi (bar) | 16 (1.1) |
| Maximum permissible pressure difference between inlet and outlet | psi (bar) | 16 (1.1) |
| Maximum permissible pressure (absolute) at gas ballast valve | psi (bar) | 17.5 (1.2) |
| Permissible ambient temperature storage / operation | °F (°C) | 14 to 140 / 50 to 104 (-10 to +60 / +10 to +40) |
| Permissible relative atmospheric moisture during operation (no condensation) | % | 30 to 85 |
| Maximum permissible installation altitude above mean sea level | ft (m) | 6500 (2000) |
| Rated motor power | hp (kW) | 0.21 (0.16) |
| No-load speed* | rpm | 0 - 3000 |
| Maximum permissible range of supply voltage (±10%) Attention: Observe specifications of rating plate! | | 100-120 V~ 50-60 Hz 200-230 V~ 50-60 Hz |
| Maximum rated current at: 100-120 V~ 50-60 Hz 200-230 V~ 50-60 Hz | A A | 1.6 0.7 |
| Device fuse Fuse of VACUU•BUS 24V DC supply | | F7A fuse on the circuit board T0.5A slow blow fuse (with automatic reset) on the circuit board |
| Motor protection | | current limitation (temperature sensor on the circuit board) |
| Degree of protection IEC 529 | | IP 20 |

| Type | | PC 3001 basic |
|---|--------------|--|
| Inlet | | hose nozzle for tubing I.D. 1/4" / 3/8" (hose nozzle DN 6/10 mm) |
| Outlet | | hose nozzle for tubing I.D. 3/8" (hose nozzle DN 10 mm) / silencer |
| A-weighted emission sound pressure level** (uncertainty K_{pA} : 3 dB(A)) | dB(A) | 42 |
| Dimensions L x W x H approx. | in (mm) | 9.9 x 10.1 x 15.7 (251 x 256 x 400) |
| Weight approx. | lbs. (kg) | 14.1 (6.4) |

* Running smoothly only at motor speeds higher than 200 rpm

** Measurement according to EN ISO 2151:2004 and EN ISO 3744:1995 at 1500rpm and ultimate vacuum with exhaust tube at outlet.

Gas inlet temperatures

| Operating condition | Inlet pressure | Permitted range of gas temperatures at inlet |
|-----------------------------|---|--|
| Continuous operation | > 75 Torr (100 mbar) (high gas load) | ➡ 50 °F to 104 °F (+10°C to +40°C) |
| Continuous operation | < 75 Torr (100 mbar) (low gas load) | ➡ 32 °F to 140 °F* (0°C to +60°C*) |
| Short-time (< 5 minutes) | < 75 Torr (100 mbar) (low gas load) | ➡ 14 °F to 176 °F* (-10°C to +80°C*) |

* if pumping potentially explosive atmospheres: 50 °F to 104 °F (+10°C to +40°C)

We reserve the right for technical modification without prior notice!

Wetted parts

| Components | Wetted materials |
|-------------------------|---|
| Pump | |
| Housing cover | PTFE |
| Head cover | ETFE carbon fiber reinforced |
| Diaphragm clamping disc | ETFE carbon fiber reinforced |
| Diaphragm | PTFE |
| Valve | FFKM |
| Pumping unit | |
| Inlet pumping unit | PP |
| Outlet pumping unit | PTFE (hose nozzle) PVC / PP (silencer) |
| Tubing | PTFE |
| Screw-in fittings | ETFE / ECTFE |

Abbreviations

| | |
|---------------|----------------------------------|
| ETFE: | Ethylene/Tetrafluoroethylene |
| ECTFE: | Ethylene/Chlorotrifluoroethylene |
| FFKM: | Perfluoro elastomer |
| PP: | Polypropylene |
| PTFE: | Polytetrafluoroethylene |
| PVC: | Polyvinyl chloride |

Pump parts

| Position | Component |
|----------|--------------------------------------|
| 1 | MD 1C VARIO chemistry diaphragm pump |
| 2 | Selection knob for motor speed |
| 3 | Mains connection |
| 4 | ON/OFF switch |

| Position | Component |
|----------|---------------------------------------|
| 5 | Inlet |
| 6 | Outlet (supplementary: with silencer) |
| 7 | Gas ballast valve |
| 8 | Handle |

PC 3001 basic



Upgrade kits for PC 3001 basic

| | |
|---|--------|
| Upgrade kit CVC 3000 with inlet separator | 699921 |
| Upgrade kit emission condenser | 699922 |



PC 3001 basic with
upgrade kit CVC 3000
with inlet separator



PC 3001 basic with upgrade
kit emission condenser

PC 3001 basic with upgrade
kit CVC 3000 with inlet separator
and
upgrade kit emission condenser
equivalent to **PC 3001 VARIO^{pro}**



Use and operation

Notes regarding the selection knob and the motor speed

Turning the knob to the left decreases the motor speed, turning the knob to the right increases the motor speed.

Pumping at **high motor speed** increases the **pumping speed** of the pump. Ensure sufficient cooling of the pump!

Pumping at **low motor speed** increases the lifetime of diaphragms and valves!

The pump attains the best ultimate vacuum in the low speed range between approx. 600 and 1000 rpm.

Installing a pump in a vacuum system



- ➔ If dangerous or polluting fluids could be released at the outlet, install an appropriate system to catch and dispose of those fluids.



- ☞ Connect a gas-tight exhaust line at the pump outlet if necessary. Always vent exhaust gases appropriately (e.g., into a fume hood).
- ☞ Never block the gas outlet (hose nozzle 3/8" (10 mm) / silencer). The exhaust line must always be free of obstructions (no back pressure) to ensure an unimpeded discharge of gas. The cross-section of the outlet tubing must be at least the size of the pump's exhaust connection.
- ☞ Operation with silencer at the outlet: Check the silencer regularly for chemical attack and deposits, replace if necessary or use an exhaust line without silencer.
- ☞ Particles and dust must not be aspirated. If necessary, you must install appropriate filters. You must ensure their suitability concerning gas flow, chemical resistance and resistance to clogging prior to use.

- ☞ Make sure ventilation is adequate, especially if the pump is installed in an enclosure, or if the ambient temperature is elevated. Provide external ventilation, if necessary.

CAUTION

- Reduce the transmission of vibration. Prevent mechanical load due to rigid pipelines. Insert elastic hoses or flexible elements as couplings between the pump and rigid pipes.

Note: Flexible elements will compress or flatten when evacuated if not designed for use under vacuum.

- Hose connections at the pump inlet must always be gas tight.
- A power failure may cause accidental ventilation of the pump, especially if the gas ballast valve is open. If this constitutes a potential source of danger, take appropriate safety measures.
- Check the power source and the pump's rating plate to be sure that the power source and the equipment match in voltage, phase, and frequency.

NOTICE

The ON/OFF switch is at the left side of the pumping unit. After switching off the pump, wait minimum 60 sec. before switching on again.

Make sure ventilation is adequate to maintain recommended operating temperature. Keep a minimum distance of 2 in (5 cm) between the cooling fan and surrounding items (e.g., housing, walls, etc.), or else install an external automatic ventilation system.

Use connecting hoses with large diameter and keep them as short as possible to avoid flow losses. Locate the pump as closely as possible to the application.

Always install outlet tubing descending from the pump or provide other measures to avoid backflow of condensate towards the pump.

When assembling, ensure **vacuum-tightness**. After assembly, check the whole system for leaks.

Secure hose connections at the pump appropriately, e.g., with hose clamps, to protect against accidental detachment.

To reduce pump noise emanating from the pump exhaust port, connect an exhaust hose or use a silencer.

During operation

DANGER

- ➔ Vent and dispose of **potentially dangerous gases or vapors** at the outlet of the pump appropriately.

WARNING

- ☞ Due to the high compression ratio, the pump might generate overpressure at the outlet. Check pressure compatibility with system components (e.g., exhaust tubing or exhaust valve) at the outlet. Ensure that the pump outlet is neither blocked nor restricted.

- ☞ **Maximum ambient temperature:** 104 °F (40 °C)
Check the maximum temperatures, if installing the pump in a cabinet or a housing. Make sure ventilation is adequate, especially if the ambient temperature is elevated.

CAUTION

- If the pump is installed at an altitude of more than 6500 ft (2000 m) above mean sea level, check compatibility with applicable safety requirements, and adopt suitable measures. There is a risk of the motor overheating due to insufficient cooling.
- Check compatibility with the **maximally permitted pressure** at outlet and the **maximum pressure difference** between inlet and outlet ports.

NOTICE

Do not start the pump if the **pressure difference between inlet and outlet ports exceeds max. 16.0 psi (1.1 bar)**. Attempts to start the pump at higher pressure difference may cause stalling and damage of the motor.

If pumping condensable vapors (water vapor, solvents, etc.), let the pump run with **gas ballast** to help purge any condensation in the pump.

Prevent internal condensation, transfer of liquids or dust. The diaphragms and valves will be damaged, if liquids are pumped in significant amounts.

Check the pump regularly for external soiling and deposits. Clean the pump if necessary to avoid an increase of the pump's operating temperature.

A temperature sensor at the circuit board protects the motor: Current limitation in the event the temperature at the circuit board raises above 158°F (70°C). At temperatures above 185°F (85°C) the pump is switched off. In the event of a motor blockage (after 10 start-up attempts) the pump is switched off.

Note: Only manual reset is possible. Disconnect the pump from the power source. Identify and eliminate the cause of failure.

Avoid overheating (e.g., due to hot process gases).

A warm up period (approximately 15 min.) is required to ensure that the rated ultimate vacuum and pumping speed are attained.

Important notes regarding the use of gas ballast

Gas ballast is a continuous purge to keep the pump's interior as clean as possible and to reduce the possibility of condensation inside the pump.



- ➔ Air and pumped media might react inside the pump or at the outlet of the pump and form hazardous or explosive mixtures, when you use air rather than inert gas for the gas ballast. This constitutes a risk of significant damage to equipment and/or facilities, a risk of personal injury or even loss of life.

WARNING

☞ Make sure that air/gas intake through the gas ballast valve can never lead to hazardous, explosive or otherwise dangerous mixtures. If in doubt, use inert gas.

NOTICE

To reduce condensation in the pump, do not pump vapor before the pump has reached its operating temperature. Open the gas ballast valve when pumping condensable vapors. Turn gas ballast cap to open valve.

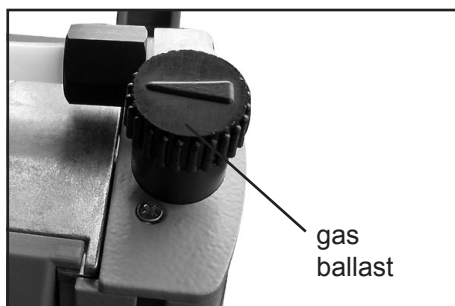

For **condensable vapors** (water vapor, solvents, etc.):

- The gas ballast valve is open if the arrow on the gas ballast cap is pointing towards the pump.
- With gas ballast valve open, the ultimate vacuum will be reduced.
- Use inert gas for gas ballast to avoid the formation of explosive mixtures. **Attention:** maximum supply pressure of inert gas: 17.5 psi (1.2 bar) absolute.
- Close the gas ballast valve by turning the cap 180°.

In case of low boiling solvents (when the formation of condensate is unlikely), the use of gas ballast might be unnecessary.

Shutdown & storage

The pump can be switched off under vacuum.

NOTICE**Short-term:**

Has the pump been exposed to condensate?

- Allow the pump to continue to run at atmospheric pressure for a few minutes.

Has the pump been exposed to media which may damage the pump materials or form **deposits**?

- Check and clean pump heads if necessary.

Long-term:

- Take measures as described above regarding short-term shutdown.
- Separate the pump from the application.
- Close inlet and outlet ports (e.g., with transport caps).
- Close the gas ballast valve.
- Drain catchpots (if applicable).
- Store the pump under dry conditions.

Accessories

Upgrade kits:

| | |
|--|---------------|
| Upgrade kit CVC 3000 with inlet separator | 699921 |
| Upgrade kit emission condenser | 699922 |

Accessories for vacuum controller CVC 3000:

| | |
|--|---------------|
| External pressure transducer VSK 3000 | 636657 |
| capacitive, ceramic diaphragm sensor 1080-0.1 mbar | |
| Coolant valve VKW-B, 24 V= | 674220 |
| Venting valve VBM-B / KF 16, 24 V= | 674217 |
| KF 16 / hose nozzle 6/10 mm, 24 V= | |
| VACUU•BUS Y-type adapter | 636656 |
| VACUU•BUS extension cable, 6.6ft (2m)..... | 612552 |
| Serial cable RS 232C, 9-pin, Sub-D..... | 637837 |

Troubleshooting

| Fault | Possible cause | Remedy |
|--|--|---|
| <input type="checkbox"/> Pump does not start or stops immediately. | <ul style="list-style-type: none"> ➔ Electrical power cord not plugged in, electrical supply failure? ➔ Selection knob for motor speed has been turned to the left stop? ➔ Overpressure in outlet line? ➔ Motor overloaded? ➔ The VACUU•BUS fuse has been triggered, e.g., load in the VACUU•BUS system too high or short circuit at connected valves? | <ul style="list-style-type: none"> ✓ Plug in power cord. Check electrical supply voltage. Check fuse. ✓ Turn the selection knob to the right. ✓ Remove blockage in line, open valve, or reduce overpressure. ✓ Allow motor to cool down, identify and eliminate cause of failure. Manual reset is necessary. Switch off pump or unplug. ✓ Remove VACUU•BUS components (e.g., valves). The fuse is self-resetting. |
| <input type="checkbox"/> Pump does not achieve its ultimate vacuum or usual pumping speed. | <ul style="list-style-type: none"> ➔ Centring ring at small flange connection not correctly positioned, or leak in the pipeline or vacuum system? ➔ Long, narrow vacuum line? ➔ Pump has been exposed to condensate? ➔ Deposits have been formed inside the pump? ➔ Diaphragms or valves damaged? ➔ Outgassing substances or vapor generated in the process? | <ul style="list-style-type: none"> ✓ Check pump directly - connect vacuum gauge directly at pump inlet - then check connection, pipeline and vacuum system if necessary. ✓ Use lines with larger diameter, length as short as possible. ✓ Allow pump to run for some minutes with atmospheric pressure at the inlet to purge. ✓ Clean and inspect the pump heads. ✓ Replace diaphragms and/or valves. ✓ Check process parameters. |

| Fault | Possible cause | Remedy |
|--|--|--|
| <input type="checkbox"/> Pump does not achieve its ultimate vacuum or usual pumping speed. | <input checked="" type="checkbox"/> Pump temperature too high (motor speed reduced)? | <input checked="" type="checkbox"/> Ensure sufficient cooling of the pump or reduce inlet pressure. |
| <input type="checkbox"/> Pump too noisy. | <input checked="" type="checkbox"/> Atmospheric or high pressure at the pump inlet? <input checked="" type="checkbox"/> Diaphragm crack or diaphragm clamping disc loose? <input checked="" type="checkbox"/> Other than above mentioned causes? | <input checked="" type="checkbox"/> Connect hose or silencer to pump outlet. Be careful not to cause outlet over-pressure, especially with condensable vapors. <input checked="" type="checkbox"/> Perform maintenance. <input checked="" type="checkbox"/> Contact local distributor. |
| <input type="checkbox"/> Pump seized. | | <input checked="" type="checkbox"/> Contact local distributor. |

Replacing diaphragms and valves

☞ Please read section "Replacing diaphragms and valves" completely before starting maintenance.

The pictures may show other versions of pumps. This does not change the method of replacing diaphragms and valves.

DANGER

➔ Never operate the pump if covers or other parts of the pump are disassembled.



➔ Before starting maintenance, **disconnect the electrical power cord**. Wait **two minutes** after isolating the equipment from AC power to allow the capacitors to discharge.

➔ Ensure that the pump cannot be operated accidentally.

➔ **Note:** The pump might be contaminated with the process chemicals that have been pumped during operation. Ensure that the pump is decontaminated before maintenance.

➔ Avoid the release of pollutants.

WARNING

☞ Never operate a defective or damaged pump.

☞ Take adequate precautions to protect people from the effects of dangerous substances that may have contaminated the pump and may be released upon disassembly. Ensure that the maintenance technician is familiar with the safety procedures which relate to the products processed by the pumping system.

Use appropriate protective clothing, safety goggles and protective gloves.

☞ Allow sufficient cooling of the pump before starting maintenance.

☞ **Vent the pump and isolate it from the vacuum system before you start maintenance.**

NOTICE

Ensure that maintenance is done only by suitably trained and supervised technicians.

The valves and diaphragms are wear parts. If the rated ultimate vacuum is no longer achieved or in case of increased noise level, the pump interior, the diaphragms and the valves must be cleaned and the diaphragms and valves must be checked for cracks or other damage.

All bearings are encapsulated and are filled with long-life lubricant. Under normal operating conditions, the drive system is maintenance free.

In demanding circumstances, it may be efficient to check and clean the pump heads on a regular basis. In normal use, the lifetime of the diaphragms and valves is typically 15,000 operating hours.

- Prevent internal condensation, transfer of liquids or dust. The diaphragms and valves will be damaged if liquid is pumped in significant amount.
- Carry out maintenance frequently if the pump is exposed to corrosive media or in case of deposits.
- Regular maintenance will improve the lifetime of the pump and also protect both users and the environment.

Service kit MD 1C (diaphragms, valves, diaphragm key) **696828**

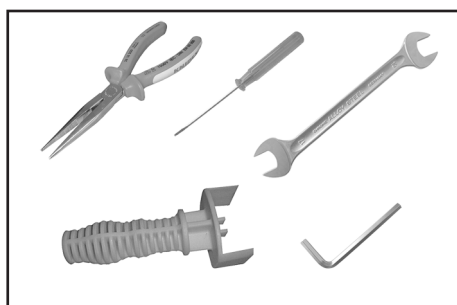
**Tools required (metric):**

- Diaphragm key width 46 mm
- Open end wrench width 14 / 17 mm
- 4 / 5 mm wide Allen key
- 2.5 mm wide slotted screwdriver
- Flat pliers

Cleaning and inspecting the pump heads

☞ Service only one side of the pump at a time to avoid the mixing of parts.

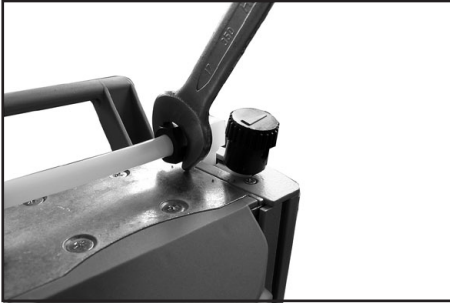

➤ Loosen the union nut (K) of the hose connection next to the gas ballast valve with an open-ended wrench (w/f 17).



➤ Turn the fitting (L) with an open-ended wrench (w/f 14) to detach the hose from the pump head (1/4 of a turn at maximum).

☞ Do not remove the elbow fitting from the pump head; during reassembly a leak may result.

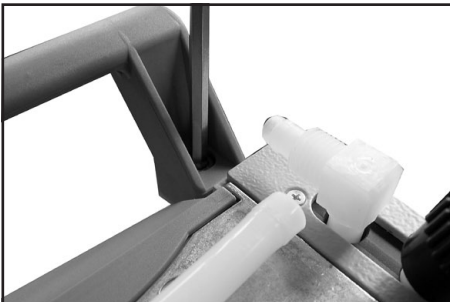

➤ Loosen the screw affixing the handle (use 5 mm wide Allen key) at one housing cover.

Disassembling the housing cover at the inlet side



➤ Lay the pumping unit on its side with the pump heads to be maintained at the top. Support the pumping unit appropriately.

➤ Disassemble the housing cover (A) to check the valves (B).

➤ Unscrew six Allen screws with a 4mm wide Allen key. Remove the housing cover with housing cover insert (A) together with head covers (C) and valves (B).

☞ Never use a pointed or sharp-edged tool to remove parts (e.g., screwdriver). We recommend using a rubber mallet or compressed air (to be blown carefully into port).

View of the disassembled pump head parts

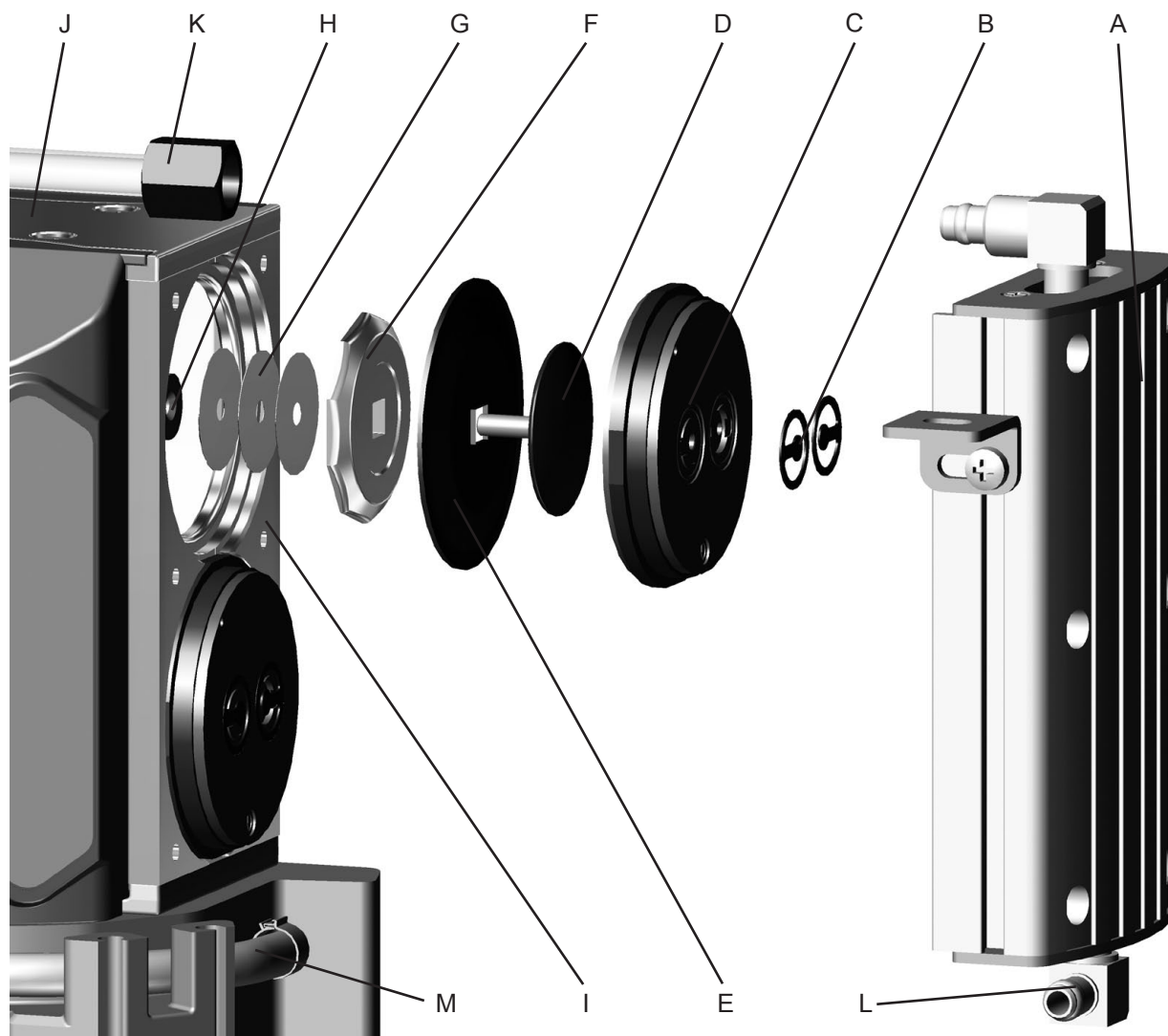

Pump head parts:

A: Housing cover with insert
 B: Valves
 C: Head cover
 D: Diaphragm clamping disc
 with square head screw
 E: Diaphragm
 F: Diaphragm support disc

G: Washer(s)
 H: Connecting rod
 I: Housing
 J: Housing bearing flange
 K: Union nut
 L: Fitting
 M: Hose connection



- Remove the head cover (C) carefully from the housing cover (A). Note position and alignment of valves (B). Remove the valves.
- ☞ Replace valves if necessary.
- ☞ Use petroleum ether or other industrial solvent to remove deposits. Do not inhale vapors.

Replacing the diaphragm

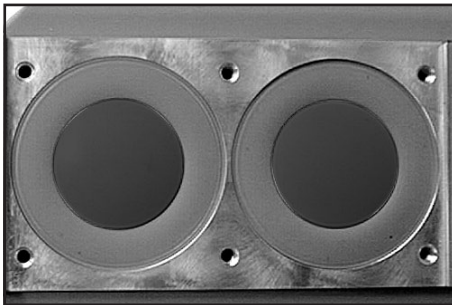

- ☞ Check diaphragms (E) for damage and replace if necessary.

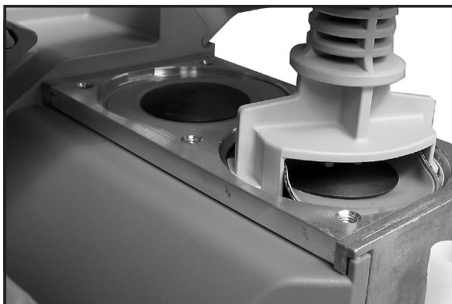

- Lift diaphragm carefully sidewise.
- ☞ Never use a pointed or sharp-edged tool to lift the diaphragm. If necessary, press down the diaphragm clamping disc of the adjacent pump head to raise the diaphragm into its uppermost turning point position.
- Use the diaphragm key to grip the diaphragm support disc (F) below the diaphragm.
- Press down the diaphragm clamping disc to bring the diaphragm into its lower turning point position. Unscrew diaphragm support disc (F) with diaphragm (E) and diaphragm clamping disc (D).
- Check for washers (G) between the diaphragm support disc (F) and the connecting rod (H). Do not mix the washers from the different pump heads, since these are set at the factory to ensure proper pump performance. Make sure that the original number is reassembled at the individual pump head.
- ☞ Too few washers: The pump will not attain vacuum specification. Too many washers: Diaphragm clamping disc will hit head cover, causing noisy operation and possibly causing the pump to seize up.

- ☞ If the old diaphragm is difficult to separate from the diaphragm support disc, immerse assembly in naphtha or petroleum ether. Do not inhale vapors!

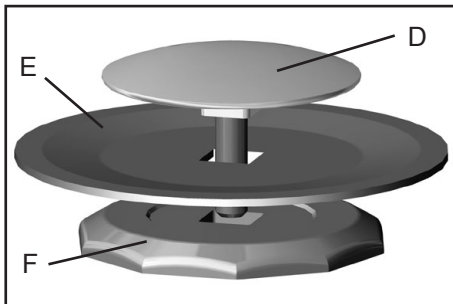

- ➔ Position new diaphragm (E) between diaphragm clamping disc with square head screw (D) and diaphragm support disc (F).
- ☞ **Note:** Position diaphragm with pale side towards diaphragm clamping disc (facing pump chamber).

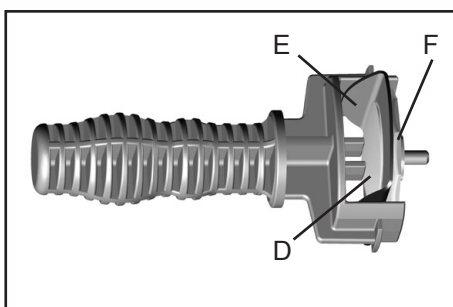

- ☞ Make sure that the square head screw of the diaphragm clamping disc is correctly seated in the guide hole of the diaphragm support disc.
- ➔ Lift the diaphragm at the side. Place the diaphragm carefully together with diaphragm clamping disc and diaphragm support disc in the diaphragm key.
- ☞ Avoid damage of the diaphragm: Do not excessively bend or crease the diaphragm.

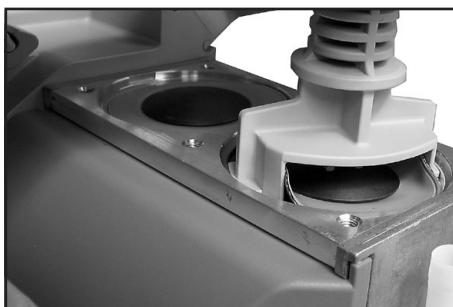

- ☞ Assemble the original number of washers (G) between diaphragm support disc (F) and connecting rod (H).
- ➔ Screw diaphragm clamping disc (D), diaphragm (E), diaphragm support disc (F), and washers (G) to connecting rod (H).

- ➔ Optimum torque for the diaphragm support disc: 3 ft·lb_f (4 Nm).
- ☞ If necessary, put the pumping unit in its upright position to screw the diaphragm clamping disc to the connecting rod. Subsequently lay the pumping unit again on its side.

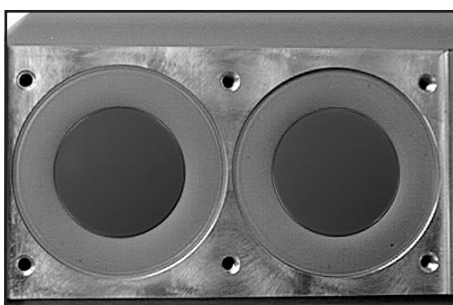

- ➔ Bring the diaphragms (E) into a position, in which they are in contact with the housing (I) and centered with respect to the bore.

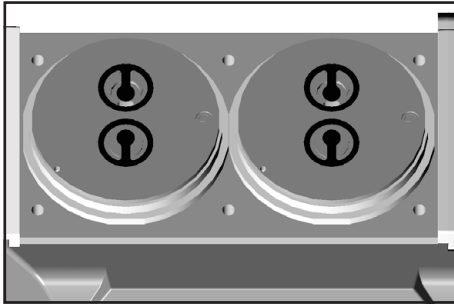

- Put on head covers (C).
- ☞ Pay attention to the correct orientation of the head covers (see figure below).
- ☞ Make sure that the diaphragms stay centered with respect to the bores so that they will become clamped uniformly between housing (I) and head covers (C).

- Put the valves (B) in place. See figure below for the correct position of the valves:

Inlet side of pump head: The valve tongue points at the kidney-shaped orifice in the valve seat (1).

Outlet side of pump head: The valve is oriented the opposite direction as the valve at the inlet side. Round orifice under the valve tongue (2).

Scheme of pump heads with head covers and valves

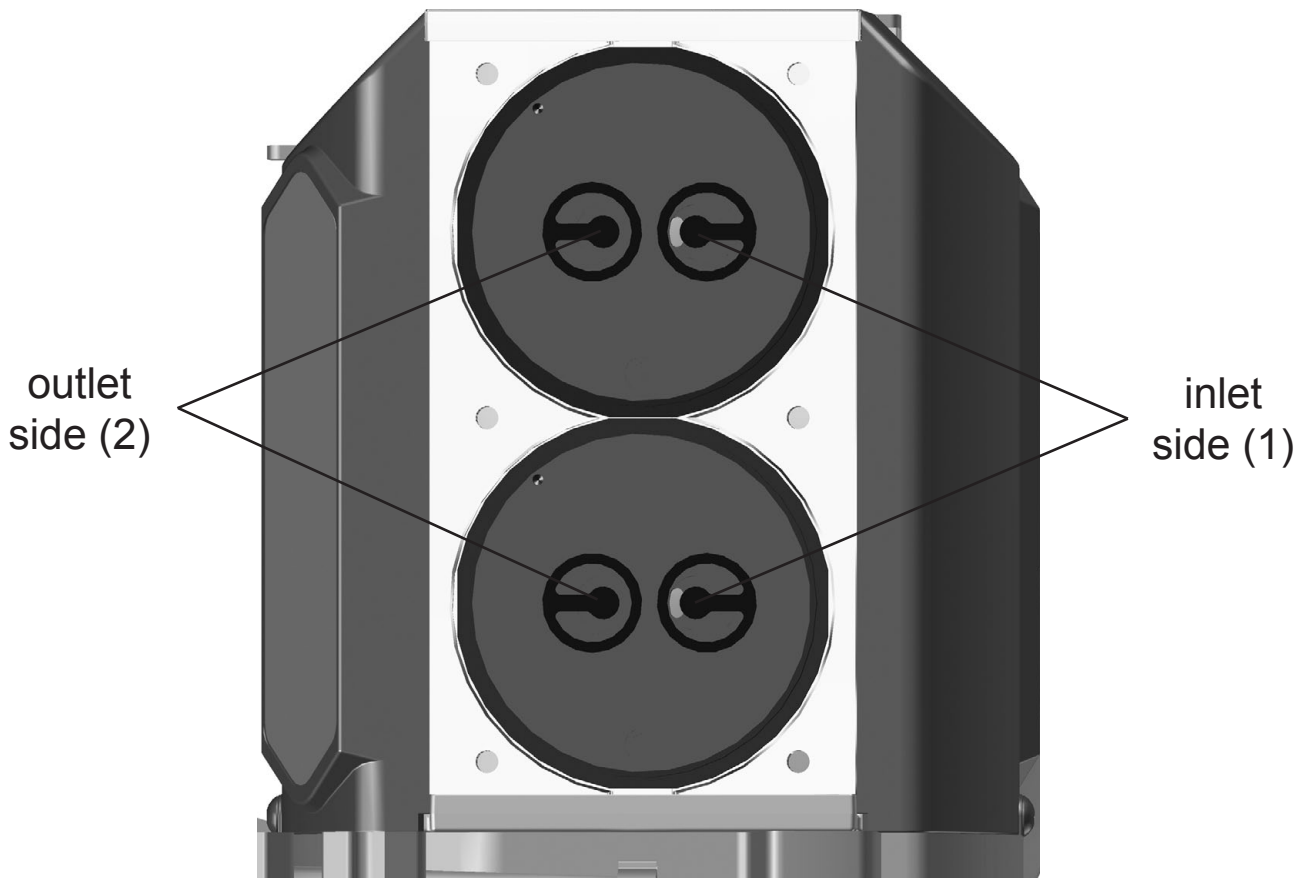

Assembling the housing cover at the inlet side

- Put on housing cover (A).
- ☞ Move housing cover slightly to ensure that the head covers are correctly positioned.



- Screw in the Allen head screws at the head cover in a diagonal pattern with a 4 mm wide Allen key, loosely at first, to align, then tighten.
- ☞ Maximum torque: 4.4 ft·lb_f (6 Nm).

Disassembling the housing cover at the side of the ON/OFF switch

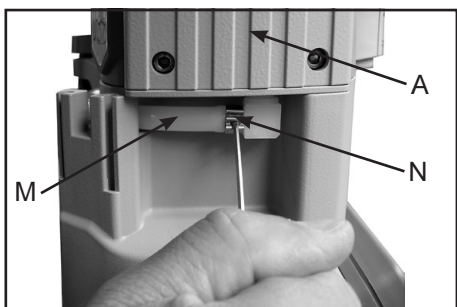

- Detach the coupling of the hose connection (M) below the housing cover (A).
- Open the hose clip (N) with a slotted screwdriver.



- Opening the hose clip:
- Apply slotted screwdriver as shown and turn.

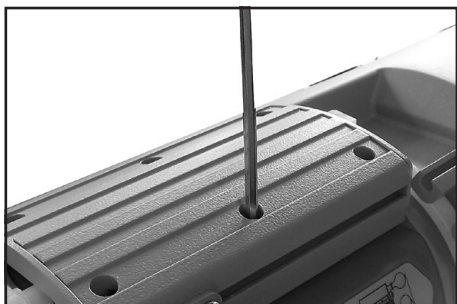

- Lay the pumping unit on its side with the pump heads to be maintained at the top. Support the pumping unit appropriately.
- Disassemble the housing cover (A) to check the valves (B).
- Unscrew six Allen screws with a 4mm wide Allen key. Remove the housing cover with housing cover insert (A) together with head covers (C) and valves (B).

- ☞ Never use a pointed or sharp-edged tool to remove parts (e.g., screwdriver). We recommend using a rubber mallet or compressed air (to be blown carefully into port).



- Raise the housing cover.
- Pull the tubing off the hose connector at the the housing cover. Do not kink the tubing.
- Remove the head cover (C) carefully from the housing cover (A). Note position and alignment of valves (B). Remove the valves.
- ☞ Replace valves if necessary.
- ☞ Use petroleum ether or other industrial solvent to remove deposits. Do not inhale vapors.

For replacing the diaphragm refer to the section "Replacing the diaphragm" above.

Assembling the housing cover at the side of the ON/OFF switch

- Put on housing cover (A).
Pay attention to a correct guidance of the connection hose towards the inlet.
- ☞ Move housing cover slightly to ensure that the head covers are correctly positioned.

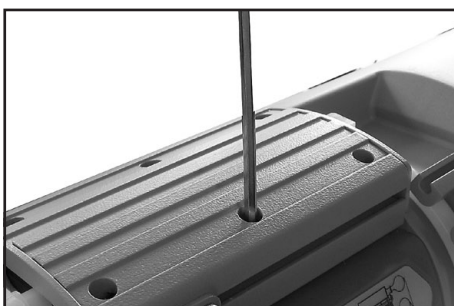

- Screw in the Allen head screws at the head cover in a diagonal pattern with a 4 mm wide Allen key, loosely at first, to align, then tighten.
- ☞ Maximum torque: 4.4 ft·lb_f (6 Nm).



- Slip connection hose onto hose connector below the housing cover.
- Close hose clip with flat pliers.

Assembling the fittings



- Attach the handle at the housing cover (use 5 mm wide Allen key)



- Slip the hose onto the hose connector by turning the fitting (L) with an open-ended wrench w/f 14.



- Tighten the union nut (K) of the hose connection with an open-ended wrench w/f 17.
- ☞ Tighten the union nut first by hand and then tighten one full turn using the open ended wrench.

Checking the ultimate vacuum

- After any intervention at the equipment (e.g., repair / maintenance) the ultimate vacuum of the pump has to be checked. Only if the pump achieves its specified ultimate vacuum, the pump's leak rate is low enough to ensure that no explosive atmospheres will occur in the interior of the equipment.

If the pump does not achieve the ultimate vacuum:

- Whenever the diaphragms and valves have been replaced, a break-in period of several hours is required before the pump achieves its ultimate vacuum.
- In case of an unusual noise, switch off pump immediately and check clamping disc positions.

If the specified ultimate vacuum is not achieved, and if this does not change after the break-in period:

Check hose connectors at pump heads for leaks. If necessary recheck valve seats and pump chambers.

Notes on return to the factory

Repair - return - DAkkS calibration

NOTICE

Safety and health of our staff, laws and regulations regarding the handling of dangerous goods, occupational health and safety regulations and regulations regarding safe disposal of waste require that for all pumps and other products, the „Health and safety clearance form“, pg. 52, must be sent to our office fully completed and signed before any equipment is shipped to the authorized service center.

Fax or mail a completed copy of the health and safety clearance form to us in advance. The declaration must arrive before the equipment. **Enclose a second completed copy with the product.** If the equipment is contaminated, you must notify the carrier.

No repair / DAkkS calibration is possible unless the correctly completed form is returned. Inevitably, there will be a delay in processing the equipment if information is missing, or if this procedure is not followed.

CAUTION

If the product has come in contact with chemicals, radioactive substances or other substances dangerous to health or environment, the product must be decontaminated **prior to sending it back to the service center.**

- Return the product to us disassembled and cleaned and accompanied by a certificate verifying decontamination or
- Contact an industrial cleaning and **decontamination service** directly or
- Authorize us to send the product to an industrial cleaning facility **at your expense.**

To expedite repair and to reduce costs, please enclose a detailed description of the problem and the product's operating conditions with every product returned for repair

We submit **repair quotations** only on request and always at the customer's expense. If an order is placed, the costs incurred for problem diagnosis are offset from the costs for repair or from the purchase price, if the customer prefers to buy a new product instead of repairing the defective one.

- **If you do not wish a repair on the basis of our quotation, the equipment may be returned to you disassembled and at your expense.**

In many cases, the **components must be cleaned in the factory** prior to repair.

For cleaning we use an environmentally friendly water-based process. Unfortunately the combined attack of elevated temperature, cleaning agent, ultrasonic treatment and mechanical stress (from pressurized water) may result in damage to the paint. Please mark in the health and safety clearance form if you wish a **repaint at your expense** just in case such a damage should occur.

We will also replace parts for cosmetic reasons at your request and at your expense.

NOTICE

Before returning the equipment, ensure that (if applicable):

- Oil sealed pumps: Oil has been drained and an adequate quantity of fresh oil has been filled in to protect against corrosion. Dispose according to regulations.
- Equipment has been cleaned and/or decontaminated (inside and outside).
- All inlet and outlet ports have been capped.
- Equipment has been properly packed, (if necessary, please order original packaging materials at your cost), marked appropriately and the carrier has been notified of any possible contamination.
- The completed health and safety clearance form is enclosed.

We thank you in advance for your understanding of the necessity for these measures that protect our employees, and ensure that your pump is protected in shipment.

Scrapping and waste disposal:

Dispose of the equipment and any components removed from it safely in accordance with all local and national safety and environmental requirements. Particular care must be taken with components and waste oil which have been contaminated with dangerous substances from your processes. Do not incinerate fluoroelastomer seals and O-rings.

- You may authorize us to dispose of the equipment **at your expense.**

Warranty

VACUUBRAND shall be liable for insuring that this product, including any agreed installation, has been free of defects at the time of the transfer of risk.

VACUUBRAND shall not be liable for the consequences of improper handling, use, servicing or operation of this product or the consequences of normal wear and tear of wearing parts such as diaphragms, seals, valves, vanes, condensers, oil and the breakage of glass or ceramic parts, for the consequences of chemical, electrochemical or electrical influences or the failure to follow the instructions in this manual.

Claims for defects against VACUUBRAND shall be limited to one year from delivery. The same shall apply to claims for damages irrespective of legal grounds.

For further information on general terms and conditions refer to www.vacuubrand.com.

Health and safety clearance form



Devices will not be accepted for any handling before we have received this declaration. Please read and comply with "Notes on return to the factory".
Oil filled pumps: Drain oil prior to shipping absolutely!

1. Device (Model): 2. Serial no.:

3. Reason for return / malfunction:

.....

4. Has the device been used in a copper process step (e.g., semiconductor production). yes no

5. Substances (gases, liquids, solids) in contact with the device / which have been pumped:

.....

.....

.....

6. Prior to return to the factory the device has been decontaminated. yes no
Description of the decontamination method and the test / verification procedure:

.....

7. The device is free of hazardous, harmful substances. yes no

8. Protective measures required for VACUUBRAND employees:

.....

9. If the paint is damaged, we wish a repaint or a replacement of parts for reason of appearance (repaint and replacement at customer's expense). yes no

10. Legally binding declaration

We assure for the returned device that all substances, which have been in contact with the device are listed in section 5 and that the information is complete and that we have not withheld any information. We declare that all measures - where applicable - have been taken listed in section "Return to the factory". By our signature below, we acknowledge that we accept liability for any damage caused by providing incomplete or incorrect information and that we shall indemnify VACUUBRAND from any claims as regards damages from third parties. We are aware that as expressed in § 823 BGB (Public Law Code of Germany) we are directly liable for injuries or damages suffered by third parties, particularly VACUUBRAND employees occupied with handling/repairing the product.
Shipping of the device must take place according to regulations.

Name: Signature:

Job title: Company's seal:

Date:

Release for repair grant by VACUUBRAND (date / signature):



**EG-Konformitätserklärung für Maschinen
EC Declaration of Conformity of the Machinery
Déclaration CE de conformité des machines**

Hersteller / Manufacturer / Fabricant:

VACUUBRAND GMBH + CO KG · Alfred-Zippe-Str. 4 · 97877 Wertheim · Germany

Hiermit erklärt der Hersteller, dass die Maschine konform ist mit den Bestimmungen der Richtlinie 2006/42/EG.

Hereby the manufacturer declares that the machinery is in conformity with the directive 2006/42/EC.

Par la présente, le fabricant déclare, que la machine est conforme à directive 2006/42/CE.

Membranvakuumpumpe / Diaphragm vacuum pump / Pompe à membrane:

Typ / Type / Type: PC 3001 basic

Artikelnummer / Order number / Numéro d'article: 696720, 696722, 696723

Seriennummer / Serial number / Numéro de série: Siehe Typenschild / See rating plate / Voir plaque signalétique

Die Maschine ist konform mit weiteren Richtlinien / The machinery is in conformity with other directives / La machine est conforme à d'autres directives:

2006/95/EG, 2004/108/EG, 94/9/EG, 2011/65/EU

Angewandte harmonisierte Normen / Harmonized standards applied / Normes harmonisées utilisées:

DIN EN 12100:2004, DIN EN 61010-1:2010 (Ed. 3), DIN EN 1012-2:2011,

DIN EN 61326-1:2006, DIN EN 1127-1:2011, DIN EN 13463-1:2009, DIN EN 50581:2013

Bevollmächtigter für die Zusammenstellung der technischen Unterlagen / Person authorized to compile the technical file / Personne autorisée à constituer le dossier technique:

Dr. J. Dirscherl · VACUUBRAND GMBH + CO KG · Alfred-Zippe-Str. 4 · 97877 Wertheim · Germany

Wertheim, 01.04.2014

ort, Datum / place, date / lieu, date

(Dr. F. Gitmans)

Managing director / Gérant

ppa.

(Dr. J. Dirscherl)

Technical Director / Directeur technique

VACUUBRAND GMBH + CO KG

Alfred-Zippe-Str. 4 · 97877 Wertheim

T +49 9342 808-0 · F +49 9342 808-5555

info@vacuubrand.com

www.vacuubrand.com



Disclaimer: Our technical literature is only intended to inform our customer. The applicability of general empirical values and results obtained under lab conditions to your specific operations depends on a number of factors beyond our control. It is, therefore, strictly the users' responsibility to very carefully check the application of these data to their specific requirements. No claims arising from the information provided in this literature will, consequently, be entertained.



Alfred-Zippe-Str. 4 · 97877 Wertheim / Germany
T +49 9342 808-0 · F +49 9342 808-5555
info@vacuubrand.com · www.vacuubrand.com

VACUUBRAND GMBH + CO KG
- Technology for Vacuum Systems -
© 2014 VACUUBRAND GMBH + CO KG Printed in Germany