

Leak Detector

HELIOT 900

Operations Manual

Please read this manual before using the equipment.
Store it carefully in a readily accessible place.

The contents of this manual cover equipment with the
following serial numbers and software versions

Serial Number: 0101 or higher



Software Version: 1.00_008 or higher

ULVAC, Inc.
Components Division

<http://www.ulvac.co.jp/>

Safety Symbols

The following safety symbols are used in order for the operator to understand items which must be observed in this operations manual and the equipment's warning notices. The language used in the symbols is classified as follows.

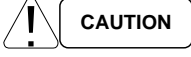





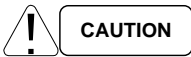
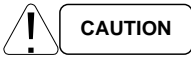
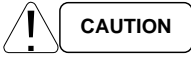



	<p>This symbol indicates the imminent possibility of death or series injury to the operator if the equipment is incorrectly used. If the work is carried out disregarding this warning, there will be a possibility of serious damage to human life or to the manufacturing facility (including this equipment).</p>
	<p>This symbol indicates the possibility of death or series injury to the operator of the equipment if it is incorrectly used. If the work is carried out disregarding this warning, there will be a possibility of damage to human life or to the manufacturing facility (including this equipment).</p>
	<p>This symbol indicates the possibility of the operator receiving a moderate injury or serious damage to the equipment or possibility of incorrect operation if the equipment is incorrectly used.</p>

Prior to Use





Thank you for purchasing our ULVAC equipment. On receipt of the equipment, please verify that the model ordered is correct and check for any damages caused during shipment.

	<p>Read this manual before installing, operating, inspecting or maintenance of the equipment and fully understand the safety precautions, specifications, and operating procedures regarding the equipment.</p>
	<p>When unpacking or moving the equipment, do not incline more than 30 degrees. Maintain a horizontal position during installation. Failure to do so may result in oil leaks or damage to the equipment.</p>
	<p>The copyright of this operations manual is held by ULVAC, Inc. No portion of this manual may be reproduced without acceptance of ULVAN, Inc. Also, it is prohibited to disclose or transfer this operations manual to any third parties without the written consent of ULVAN, Inc.</p>
	<p>Please note that the information of this operations manual is subject to change without any notice for changes in specifications and modifications of the equipment.</p>

Safety Precautions

 DANGER	<p>Power Shutdown When installing the equipment and removing the external panels for inspection and replacement of parts, turn off the MAIN POWER switch and disconnect plug from the outlet before operating. Possibilities of electric shock and damages to the equipment due to high voltage areas.</p>
 DANGER	<p>Fore Pump Exhaust Vent Do not block the fore pump exhaust vent. It may explode to cause a serious damage to human life or to the manufacturing facility when fore pump exhaust vent is pressurized</p>
 DANGER	<p>Handling of Hydrogen Gas Risk of explosion when hydrogen is mixed with 4% of air or over. Please read carefully MSDS to ensure the safety instructions of hydrogen gas and its mixture gas before handling the gas.</p>
 DANGER	<p>Power Supply Cable Always verify that the power supply cable included with the unit exceeds the unit's rating before use. Risk of fire from using a power supply cable below the unit's rating.</p>
 WARNING	<p>Input Power Supply Voltage Use $\pm 10\%$ of rated voltage indicated on the rating plate for input voltage. See section 1-1 for the rated current. Before supplying power, always verify voltage, and permissible current of the supply side. There is a possibility of serious damage to human life or manufacturing facility in case of supplying voltage outside of the rating.</p>
 WARNING	<p>Handling of Test Ports. When the equipment is in operation or during testing, do not remove the blank flange or test subject and Sniffer unit from the test port or vent the test port to atmospheric pressure by any other method other than by the method indicated in this manual. There is a risk of damaging the equipment.</p>
 CAUTION	<p>Grounding In order to prevent earth leakage, always ground the equipment with a class 1 ground. When used in Europe and North America, it is class I equipment, therefore always ground the equipment with earth.</p>
 CAUTION	<p>High Temperature Warning The pump, analyzer tube, and solenoid valve are extremely hot immediately after stopping. When servicing/replacing parts, wait for 15 minutes or more after stopping and then proceed carefully with the work. Risk of injury from burns and the possibility of damage to the equipment.</p>
 CAUTION	<p>Vibration Prohibited Do not expose the equipment to vibrations from surrounding machinery or impacts. Risk of damaging the equipment.</p>
 CAUTION	<p>Load on Test Port When connecting pipe fitting to the test port, do not place loads over 50N. Risk of damaging the equipment.</p>
 CAUTION	<p>Ensure Ventilation In order to cool the interior of the main equipment, an intake fan is installed on the left panel and an exhaust fan is installed on the right panel. Maintain spacing of 200 mm or more between all panels. Obstructing the vents increases the internal temperature of the equipment to create a risk of damaging the equipment.</p>

Handling Precautions

 CAUTION	<p>Contact to Vacuum Components The internal components in the unit's pump system have undergone precision cleaning. Do not touch with bare hands during maintenance. Risk of reducing performance of the equipment.</p>
 CAUTION	<p>Assembling of Indicator and Main Unit The indicator and the main unit are to be used as assembled for its shipment. The correct composition is essential for proper functioning of the equipment and may lead to damage.</p>
 CAUTION	<p>Activation Without Sensitivity Calibration Activation of the equipment without sensitivity calibration, regardless of the condition of the main unit, may lead to large difference in measurement values due to use of past calibrated data without any modifications. In order to maintain higher reliability, sensitivity calibration is recommended.</p>
 CAUTION	<p>Prohibit Spray of He to Vent Port Vent Port injects He unpolluted gas such as air and nitrogen to vacuum component system via vent valve. When He is sprayed to vent ports, the vacuum component system gets polluted by He and may lead to significant loss of precision in the measurement.</p>

Notes



 CAUTION	<p>List of Service Desks Please be aware that service desks listed are subject to change without notice.</p>
 CAUTION	<p>Disposal When disposing of the unit or a portion of the unit, refer to local laws and ordinances. When toxic gas is used the unit must be disposed through an industrial disposal specialist. The cost incurred to the disposal will be covered by the customer.</p>
 CAUTION	<p>2.4GHz Portable Wireless Device This unit employs 2.4GHz Portable Wireless Device compatible to IEEE 802.11b/g/n standard. Refer to nation/local laws for use.</p>

Table of Contents

	Page
SAFETY SYMBOLS.....	I
PRIOR TO USE	I
SAFETY PRECAUTIONS	II
HANDLING PRECAUTIONS.....	III
NOTES.....	III
1. HELIOT 900 SERIES SPECIFICATIONS AND CONFIGURATIONS	1
1-1 GENERAL SPECIFICATIONS.....	1
1-1-1 Common Specifications	1
1-2 COMMON SPECIFICATION.....	2
1-2-1 Base Type (901W1/901D2).....	2
1-2-2 Mobile Type (904W2/904D3/904D4).....	2
1-2-3 Sniffer unit Specification (Optional)	2
1-3 HELIOT CONFIGURATION (DRAWING).....	3
1-3-1 Base Type 901W1/901D2	3
1-3-2 Tablet.....	4
1-3-3 Tablet Stand	5
1-3-4 External view at the time of mounting to Low height cart.....	6
1-3-5 Mobile Type (904W2 / 904D3 / 904D4)	7
1-3-6 Sniffer Unit AS (Optional).....	8
1-3-7 Sniffer Unit BS (Optional).....	9
1-3-8 Sniffer Unit BT (Optional).....	9
1-3-9 Sniffer Probe for AS/BS (Optional).....	10
1-3-10 Power Supply Cable.....	11
1-4 VACUUM SYSTEM DIAGRAM	12
1-5 COMPLEX MOLECULE PUMP UNIT.....	13
1-6 CONNECTOR PANEL	14
2. SET UP.....	16
2-1 UNPACKING	16
2-2 ASSEMBLING/MOVING/INSTALLATION	17
2-2-1 Assembling	17
2-2-2 Moving/Installation	18
2-3 CONNECTION OF TEST PORT.....	19
2-3-1 Vacuum Method.....	19
2-3-2 Sniffer Method	19
2-4 ELECTRICAL CONNECTIONS	20
2-5 STORAGE.....	20
3. OPERATION OVERVIEW.....	21
3-1 POWER SUPPLY ON – TESTING – TILL STOP.....	21
3-1-1 Power Activation	21
3-1-2 Preliminary Mode	21
3-1-3 During Activation.....	21
3-1-4 Standby/Test.....	22
3-1-5 Stop	22
3-1-6 Errors.....	22
3-1-7 Power Supply OFF.....	23

3-2 WINDOW SCREEN OPERATIONS	23
3-3 MENU SCREEN	24
4. CONNECTION OF MAIN UNIT AND TABLET	26
4-1 WIRE CONNECTION	26
4-2 WIRELESS CONNECTION	27
4-2-1 When Reconnecting.....	27
4-2-2 When Resetting Connection Point.....	28
5. SETTINGS.....	29
5-1 GENERAL	29
5-2 INDICATION/MESSAGE	32
5-3 SERIAL COMM./EXT I/O	35
5-4 CALIBRATION STANDARD	38
5-5 LIST OF SETTINGS FOR SHIPMENT FROM MANUFACTURER	39
6. INFORMATION.....	41
6-1 SERVICE.....	41
6-2 START-UP DATA	41
6-3 MAINTENANCE (901W1/904W2).....	42
6-4 MAINTENANCE (901D2/904D3).....	42
6-5 ERROR LOG	43
7. STARTUP	44
7-1 STARTUP OF VACUUM METHOD	44
7-2 STARTUP OF SNIFFER METHOD	46
7-2-1 SNIFFER (FLOW RATE).....	46
7-2-2 SNIFFER (CONCENTRATION).....	47
8. TESTING	49
8-1 TEST SCREEN	49
8-1-1 Graph.....	49
8-1-2 Meter	49
8-1-3 Vac. DIAGRAM.....	50
8-1-4 VALUE	50
8-2 TEST MODE	52
8-2-1 Cycle Test.....	55
8-3 HOW TO USE [-0- ZERO].....	57
8-4 HOW TO USE [CLEAN UP].....	58
8-5 HOW TO USE [CAL. START]	59
8-6 HOW TO USE [CAL.CHECK].....	59
8-7 END OF TESTING	59
8-8 HYDROGEN MEASUREMENT	60
9. ERROR MODES.....	61
9-1 WARNING ERRORS	61
9-2 CAUTION ERRORS	62
9-3 LIST OF ERROR MESSAGES.....	63
9-3-1 Warning Errors.....	63
9-3-2 Caution Errors.....	67

10. MAINTENANCE	71
10-1 LIST OF MAINTENANCE ITEMS.....	72
10-2 MAINTENANCE PROCEDURES.....	73
10-2-1 How to Install/Remove External Panels.....	73
10-2-2 Rotary Pump.....	74
10-2-3 Pirani Gauge Head.....	76
10-2-4 Ion Source.....	78
10-2-5 Calibration Leak.....	79
10-2-6 Sintered Metal Element of Sniffer Probe Tip.....	80
10-2-7 Microseparator (Sniffer Unite BS/BT only).....	80
10-2-8 Dust Filter (Sniffer BS Unit only).....	81
10-2-9 Dust Filter (Sniffer Unit BT only).....	81
10-2-10 Fan Filter Inside the Equipment.....	82
10-2-11 Intake Fan Filter.....	82
10-2-12 Mist Oil Filter.....	83
10-2-13 Vent Filter.....	84
11. INPUT/OUTPUT SIGNALS	85
11-1 EXT. I/O.....	85
11-1-1 List of Output Signals.....	86
11-1-2 List of Input Signals.....	88
11-2 LEAK RATE.....	90
11-2-1 Output Pin Number.....	90
11-2-2 Output Table.....	90
11-3 RS232C.....	95
11-3-1 Connection of Printer.....	95
11-3-2 RS-232C Communication.....	97
11-3-3 RS-485 Communication.....	106
11-4 MICRO SD CARD.....	112
12. GUARANTEE	113
REQUEST FORM FOR REPAIR/INSPECTION OF ULVAC COMPONENTS /CERTIFICATE OF CONTAMINATION	114

1. HELIOT 900 Series Specifications and Configurations

HELIOT 900 Series Leak Detector detects leakage of Helium He/H₂ by using principles of magnetic deflection mass spectrometer.

1-1 General Specifications

1-1-1 Common Specifications

Item	Specifications	
Detectable gas	Helium ⁴ He , Hydrogen ² H ₂ ^(*)	
Minimum detectable leak (⁴ He)	< 5×10 ⁻¹³ [Pa·m ³ /s]	
Inlet pumping speed for ⁴ He	ULTRA FLOW	> 5 [l/sec]
	FINE FLOW	> 1 [l/sec]
Startup rime	2min(when no calibration) , 5min (when calibration)	
Stop time	1[min]	
Inlet port flange	NW25 (ISO)	
Input power supply	AC 100-120[V] or AC 200-240[V] (50/60Hz)	
Environmental condition	Usage for indoor	
Operating temperature range	10-40[°C]	
Operating humidity limit	35-85[%RH](with no condensation)	
Storage temperature limits	10-55[°C]	
Safekeeping humidity range	35-85[%RH](with no condensation)	
Standards	RoHS	
Over voltage category	Cat. II (IEC60664-1)	
Height condition	Equal or less than 1000m sea level	
Pollution Degree	2(IEC60664-1)	
Noise level	≦70 dB(A) 1m	
Application standards	CE	
Input/output	<ul style="list-style-type: none"> • External input/output control (approx. 20 types of signals) Test start/stop signal input, unit startup/stop signal input...etc. • Analog output : Output the leak rate and Pressure at 0 to 10 voltage. • Serial interface (RS232C/RS485) Printer output, Control by external interface 	
Controller unit	7 inch color touch panel tablet Radio Act acquired : Telec (Japan), CE (Europe), FCC (U.S.A)	
Operation range	Wire	Cable length:2m(standard)
	Wireless	40m ^(*)
Battery lasting time	3 - 8 hours ^(*)	
Language	English, Japanese, Korean, Simple Chinese, Traditional Chinese, German, Spanish	
Test modes	<u>Auto mode, Ultra flow, Fine flow, Gross flow, sniffer flow</u> 5 selectable. Optional sniffer units are required for sniffer flow.	
Valve operation	Internal valves: full automatic control. External valves: Valve output for external calibration leak valves installed externally (24V) is also full automatic control.	
Sensitivity calibration	<ul style="list-style-type: none"> • Automatic calibration execution at instrument start (with calibration leak temperature compensation and time compensation functions). • Sensitivity check function (sensitivity value can be managed) • Sensitivity calibrate function via external leak calibration (Recommend to use the external calibrated leak of 1.0×10⁻⁷ [Pam³/s] or more when the volume of the measurement tool is large.) 	

1-2 Common Specification

1-2-1 Base Type (901W1/901D2)

Type which small fore pump is on board type. Also prepared a Low height cart as an option .

Model	901W1	901D2 ^(*4)
Vacuum exhaust system fore pump (50Hz/60HZ)	Rotary pump 30/36 [ℓ/min]	Scroll pump 90/108 [ℓ/min]
Dimensions	480×320×506 [refer to outside diagrams except for sections 1-3-1,1-3-4]	
IP Protection grade	IP30	
Weight (with floor cart)	33 (46) [kg]	37 (50) [kg]
Power consumption	600 [VA]	500 [VA]

1-2-2 Mobile Type (904W2/904D3/904D4)

Type which big pump is on board in the mobile cart.

Model	904W2	904D3 ^(*4)
Vacuum exhaust system fore pump (50Hz/60HZ)	Rotary pump 135/162 [ℓ/min]	Scroll pump 250/300 [ℓ/min]
Dimensions	660×444×991 [refer to outside diagrams except for sections 1-3-5]	
Weight	77 [kg]	74 [kg]
Power consumption	1100 [VA]	650 [VA]

1-2-3 Sniffer unit Specification (Optional)

Sniffer measurement method is possible by using sniffer unit (optional) in all models.

Model	AS9	BS9	BT9
Detectable gas	Helium ⁴ He ^(*5)		
Flow rate	<0.03 [ℓ/min]	Approx. 3 [ℓ/min]	
Sniffing inlet port	Handy probe		φ6mm hose joint
Tube	1-10 [m]		
Dimensions	[refer to outside diagrams except for sections 1-3-6,1-3-7,1-3-8,1-3-9]		
Weight	Approx. 0.2 kg	Approx. 2.0 kg	
Sensitivity calibration	Prepared separately from the unit, calibration using the channel calibration leak (optional) or reference concentration gas (known He concentration). Atmosphere can also be used as 5 ppm He reference concentration gas.		

(*1) In order to reduce He back ground residues in the main unit right after activation or depending on the customer's conditions of use, it may need several hours of warm up operation.

(*2) It depends on operational environment.

(*3) It may differ depending on communication condition, brightness of the screen or volume.

(*4) Under the environment of He high concentration (>1000ppm), due to characteristics of pump configuration, the back ground becomes high and the minimum detectable leak rate may largely increase.

(*5) Specification by Sniffer method. No hydrogen can be measured.

1-3 HELIOT Configuration (drawing)

1-3-1 Base Type 901W1/901D2

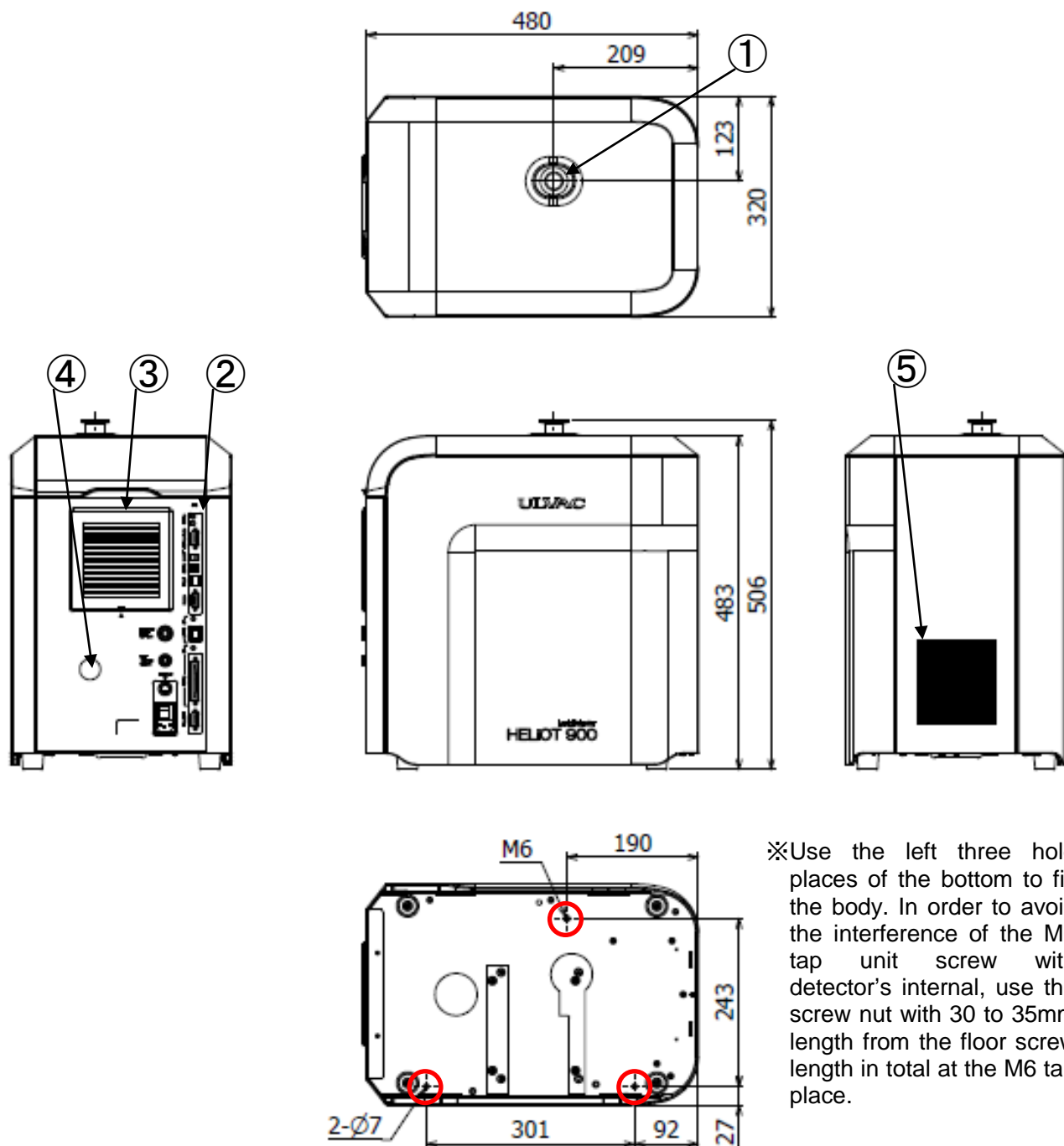

No.	Name	Function
1	Test port	Connects to the test subject or sniffer unit. (NW25)
2	Connector panel	Contains the main breaker, power supply connector, and external input/output connectors. See 6-9 for details.
3	Fan	Fan for suction (filter attached).
4	Oil view port	A view port to check the oil condition of the rotary pump. (901D2 will be a Grommet type)
5	Fan	Fan for cooling exhaust.

1-3-2 Tablet

All models operate with common tablet type computer.
The screen allows automatic rotation of 180 degrees.

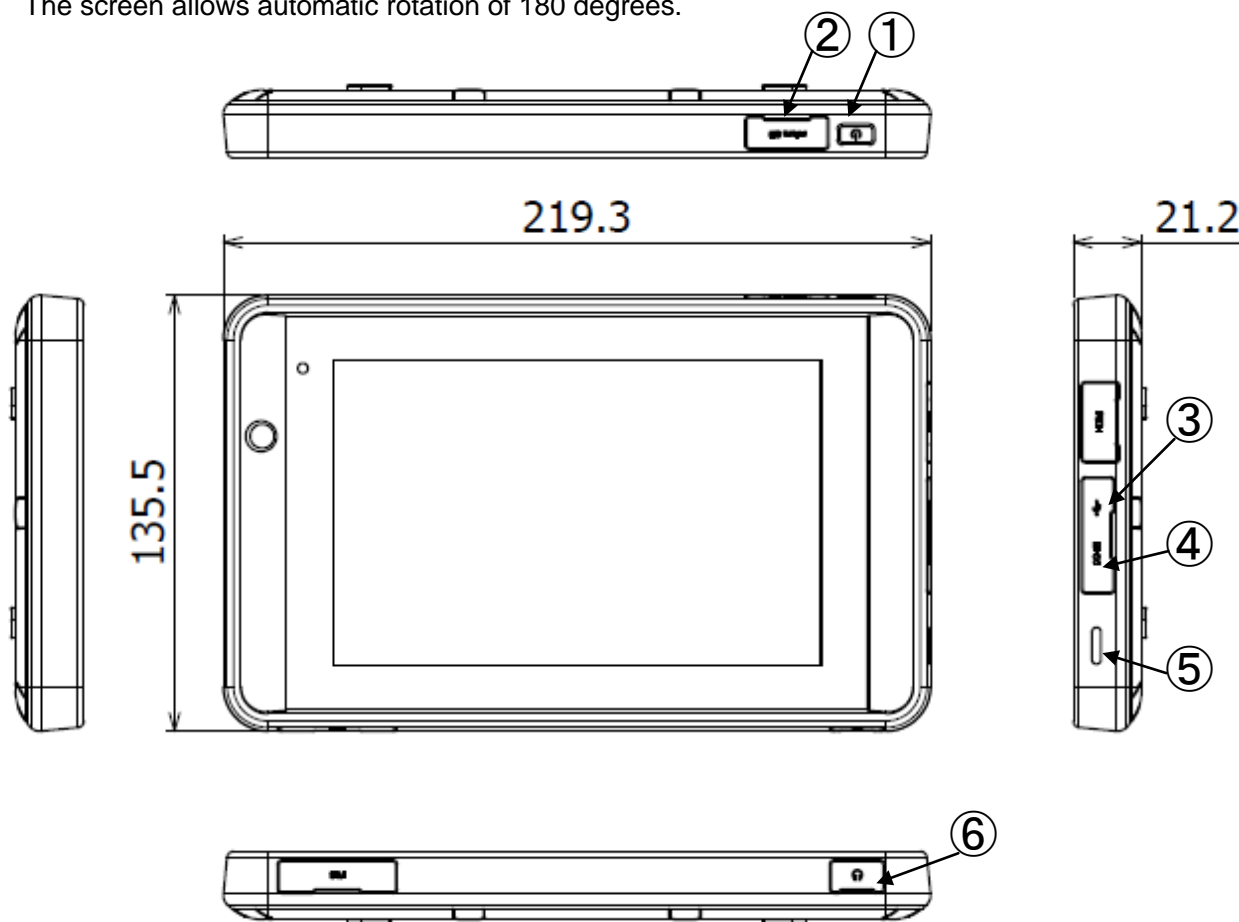

No.	Name	Function
1	Main power	Turn ON/OFF the power supply of the indicator. To turn on the power supply of the indicator, press power supply button for 2 seconds. To start the indicator from sleep mode, press power supply button for 0.5 seconds. If the indicator does not respond, keep the power supply button pressed and turn OFF the power supply mandatorily.
2	microSD card slot	MicroSD card of 8G bytes can insert. An activation data, error, each setting and test data will be logged in the microSD.
3	MiniUSB connector	Use for wiring connection of HELIOT with the tablet by attached cable.
4	DC input jack	Use for power wiring connection of HELIOT with the tablet by attached Cable or to supply a direct power from the AC adaptor.
5	Speaker	Speaker
6	φ3.5mm ear phone jack	Jack to connect the ear phone or speaker. The integrated speaker will automatically turns off when the phone jack is connected.

1-3-3 Tablet Stand

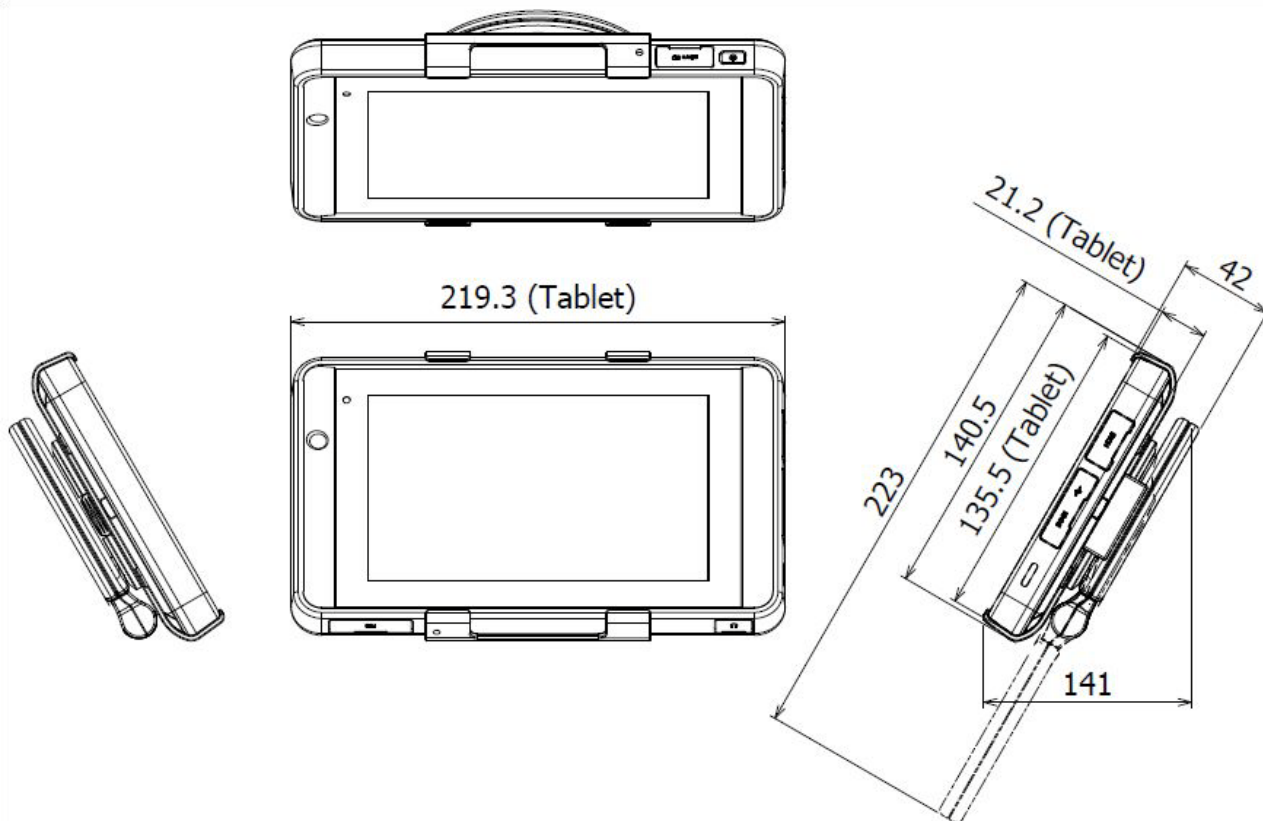

Handle is fixed to the plate. Before fixing the tablet stand with screws, remove the handle and use the fixing hole. Fixing will be with 4(pcs) flat head M3 screws.

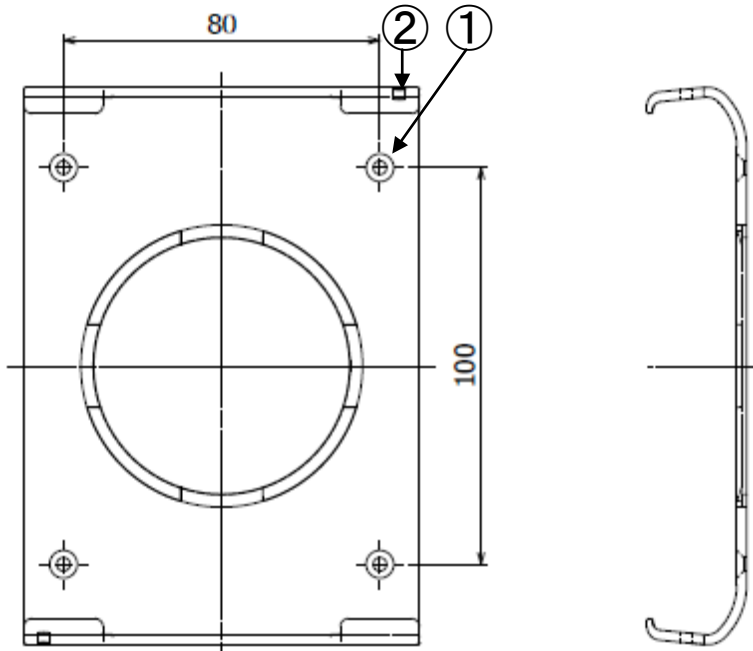

No.	Name	Function
1	Holes for securing panels	Counter sinking treated for M3 counter sunk screw. Provided for securing to your panels. M3 counter sunk screw
2	φ3 hole	Used for fixing straps for touch pens.

1-3-4 External view at the time of mounting to Low height cart.

External view at the time of 901W1 and 901D2 mounting to the optional Fronts are free wheel, rear are with lock function ring.

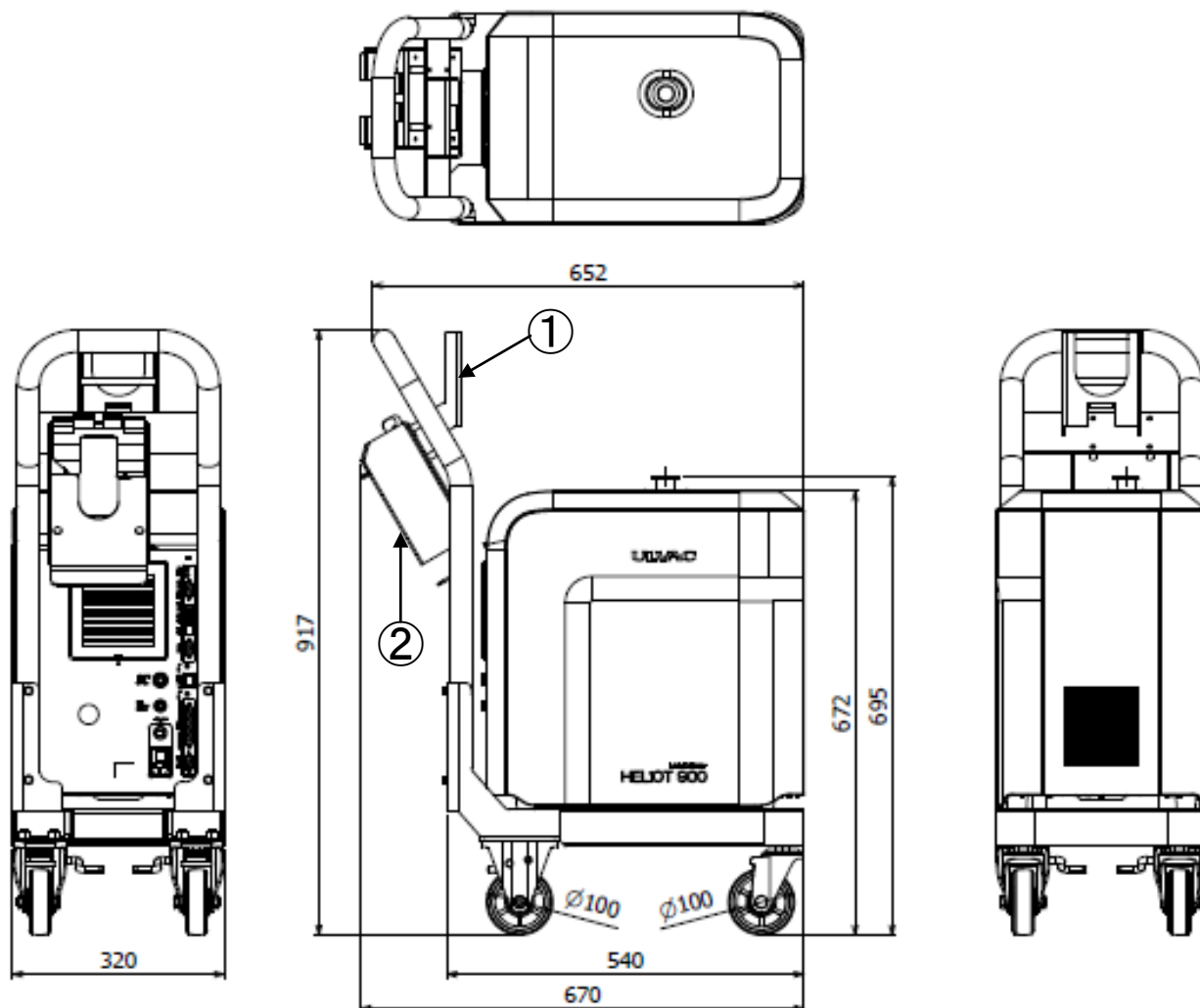

No.	Name	Function
1	Tablet holder	Holder to fix the tablet position.
2	Controller storage BOX	Optional controller storage box.

1-3-5 Mobile Type (904W2 / 904D3 / 904D4)

Fore pump equipped in the mobile cart.

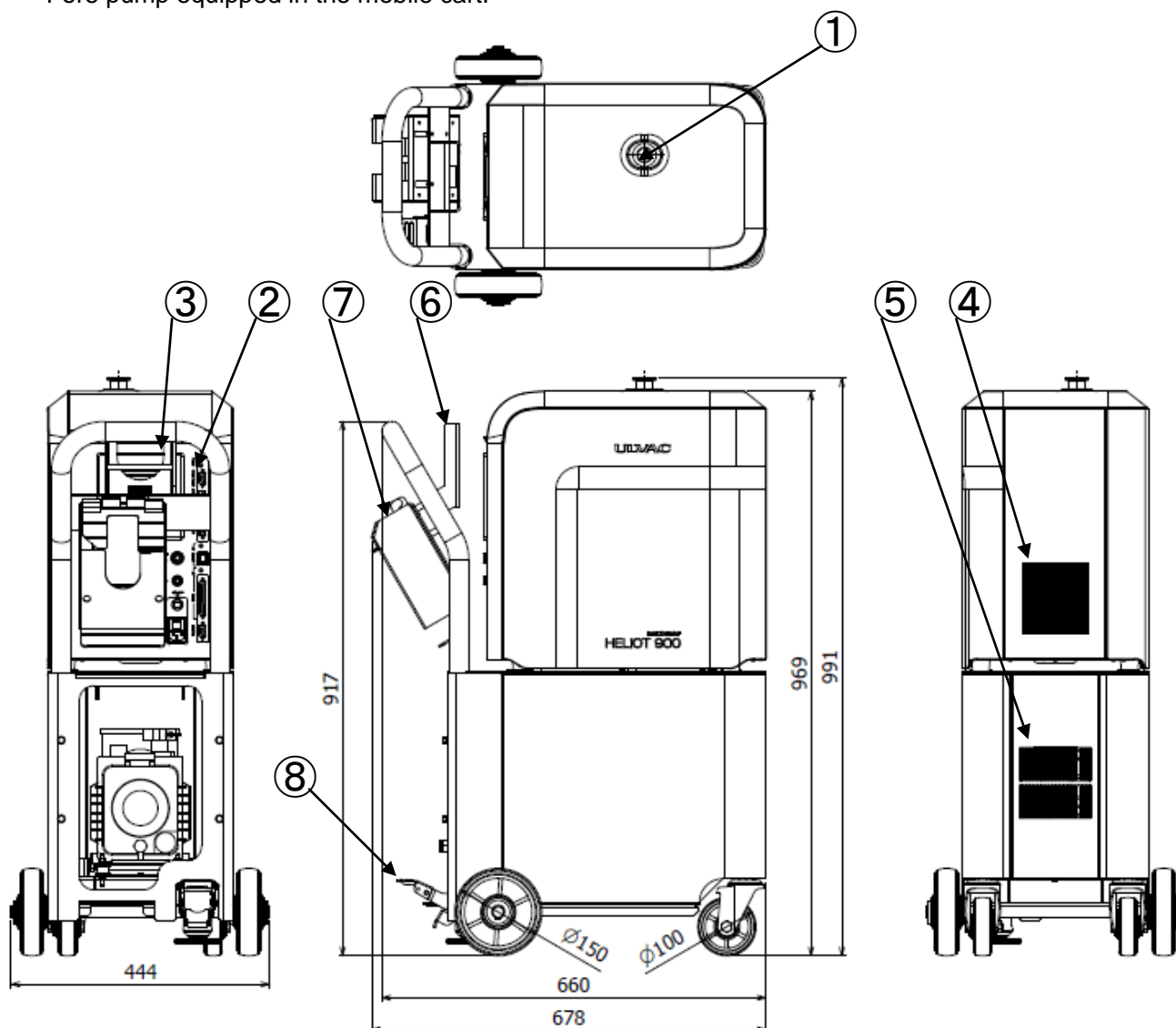

No.	Name	Function
1	Test port	Connects to the test subject or sniffer unit. (NW25)
2	Connector panel	Contains the main breaker, power supply connector, and external input/output connectors. See 6-9 for details.
3	Fan	Fan for suction (filter attached).
4	Fan	Fan for exhaust.
5	Fan	Fan for suction.
6	Tablet holder	Holder to fix the tablet position.
7	Controller storage BOX	Optional case for storing the tablet. (Option)
8	Stopper	A stopper that can fix the leak detector in a simplified manner.

1-3-6 Sniffer Unit AS (Optional)

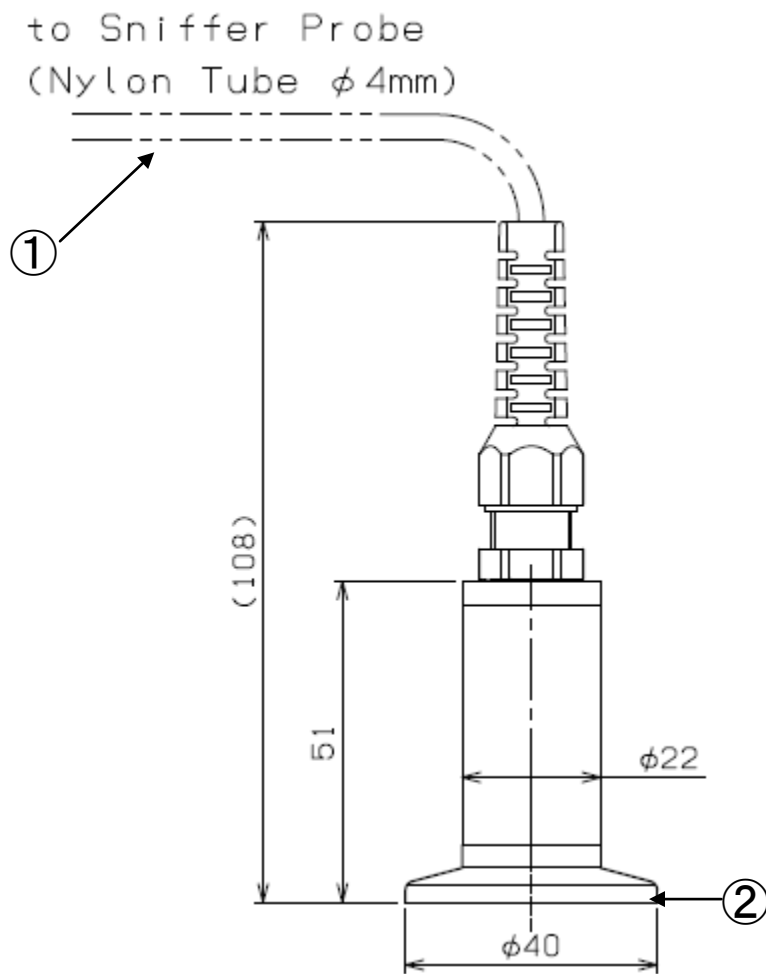

No.	Name	Function
1	Probe connection port	Used for installing Sniffer probe of Section 1-3-9.
2	Test port connection flange	Flange for connecting to the test port. (NW25)

1-3-7 Sniffer Unit BS (Optional)

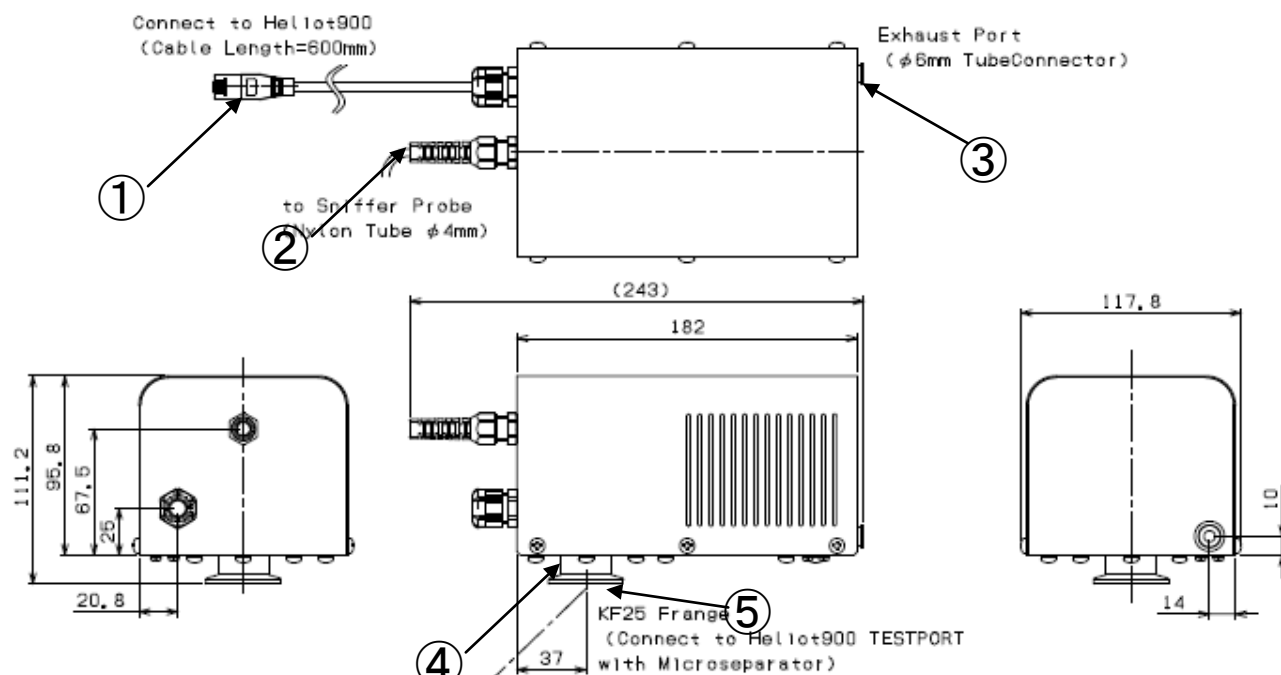

1-3-8 Sniffer Unit BT (Optional)

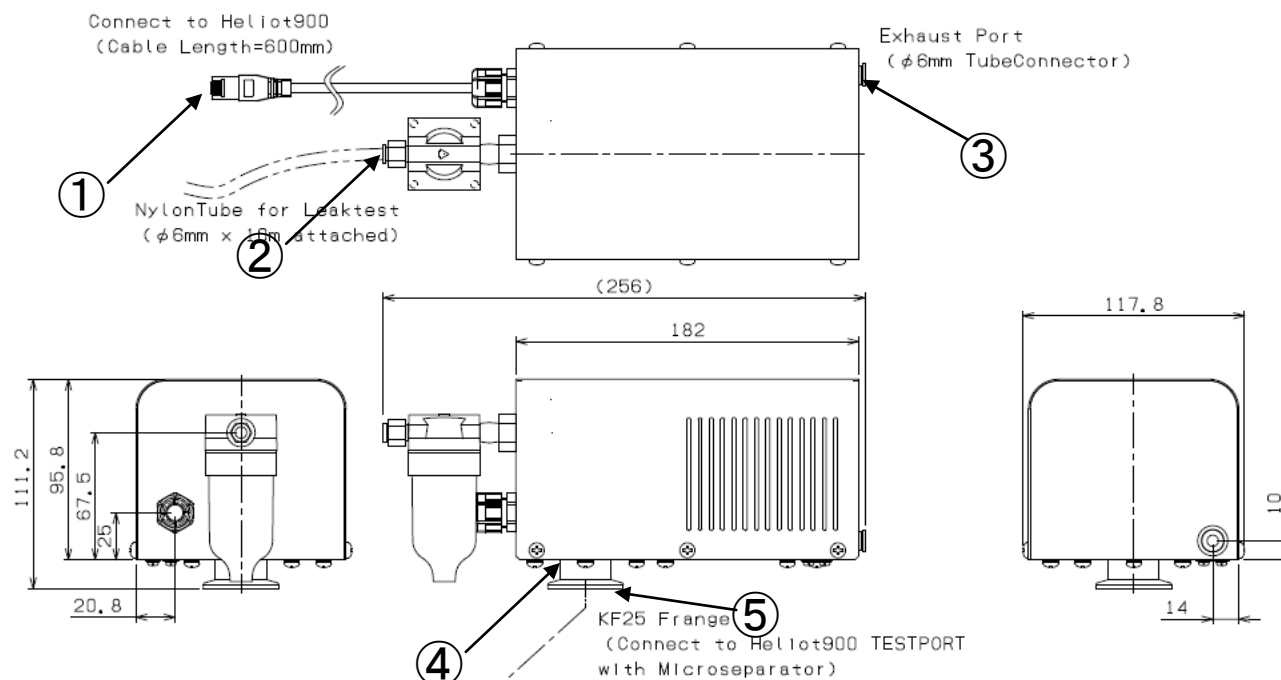

No.	Name	Function
1	Cable	Cable to connect the main leak detector and sniffer unit.
2	Probe connection port	Used for installing Sniffer probe of Section 1-3-9. Not removable.
3	φ6 joint	A joint where exhaust the suction gas.
4	Test port flange	Flange for mounting the sniffer unit to the test port.
5	Microseparator	A membrane that maintains the pressure differential between the atmosphere. To be set between the main and test port flange. Model: MS-80

1-3-9 Sniffer Probe for AS/BS (Optional)

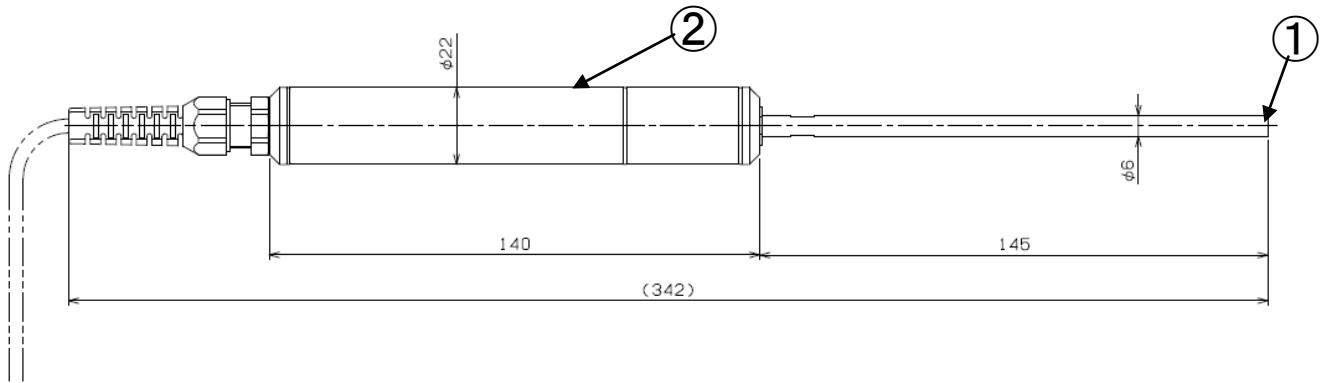

to Heliot900
 TESTPORT/Booster Pump Unit
 (Nylon Tube ϕ 4mm)

No.	Name	Function
1	Sintered filter	Filter to prevent contamination of dirt. (10 μ m)
2	Grip	The probe grip.

1-3-10 Power Supply Cable

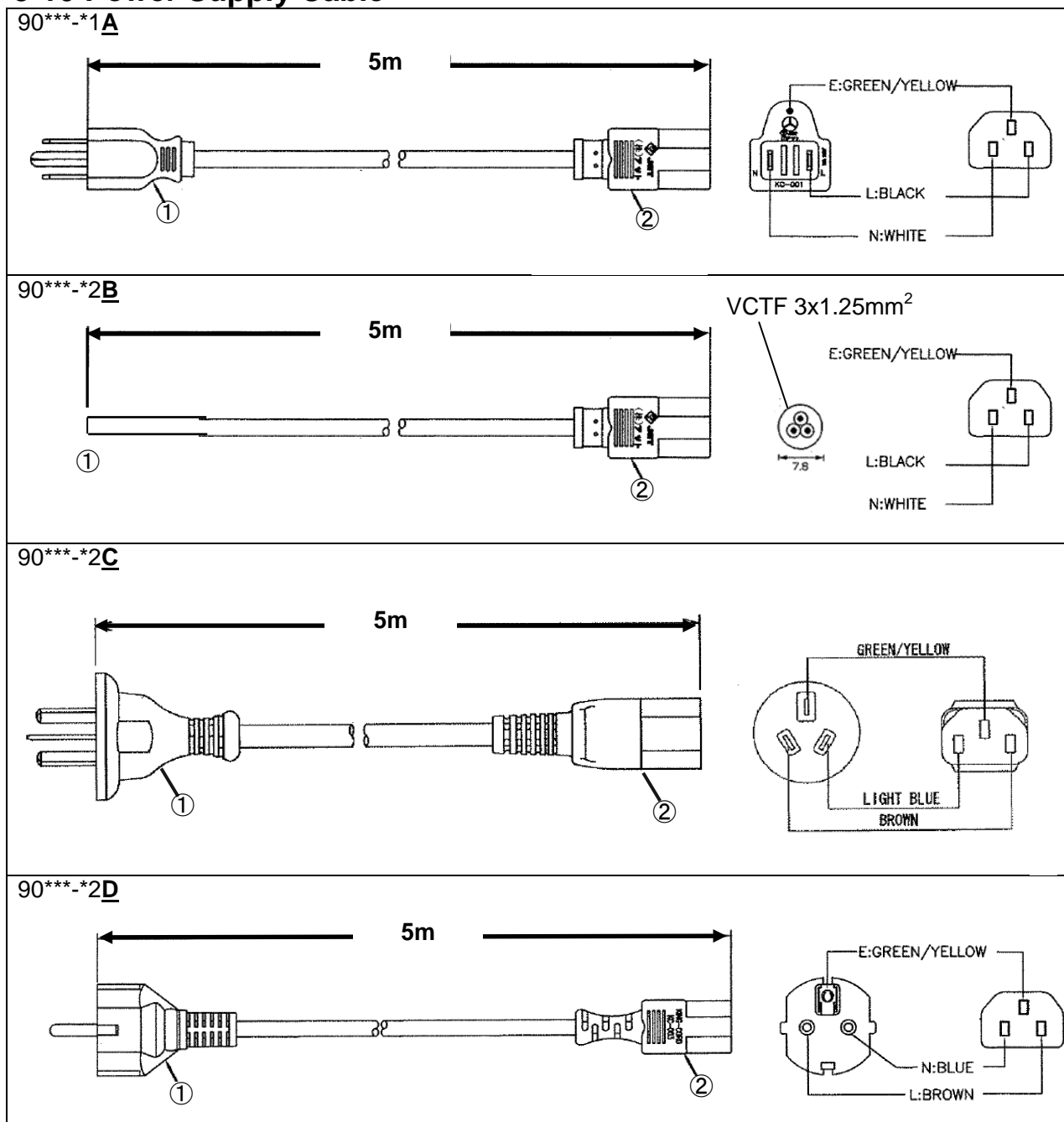

Applicable Model	Safety Standard / Nation *	Rated voltage/ Rated current
90***-1A	JIS/Japan (PSE)	AC125V / 15A
90***-2B	JIS/Japan (PSE)	AC250V / 10A
90***-2C	GB/China (CCC)	AC250V / 10A
90***-2D	VDE/Germany, KEMA/Netherlands, CEBC/Belgium, oVE/Austria, SEMKO/Sweden, DEMKO/Denmark, FIMKO/Finland	AC250V / 10A

* Please purchase a power cable that applied to your nation's standard, rated voltage and rated current when your nation's standard is not included above

No.	Name	Function
1	Plug	Connect to your electric socket.*
2	Connector	Connect to the connector panel of HELIOT.

* Power cable attached to 90***-2B is cut without plug connection.

1-4 Vacuum System Diagram

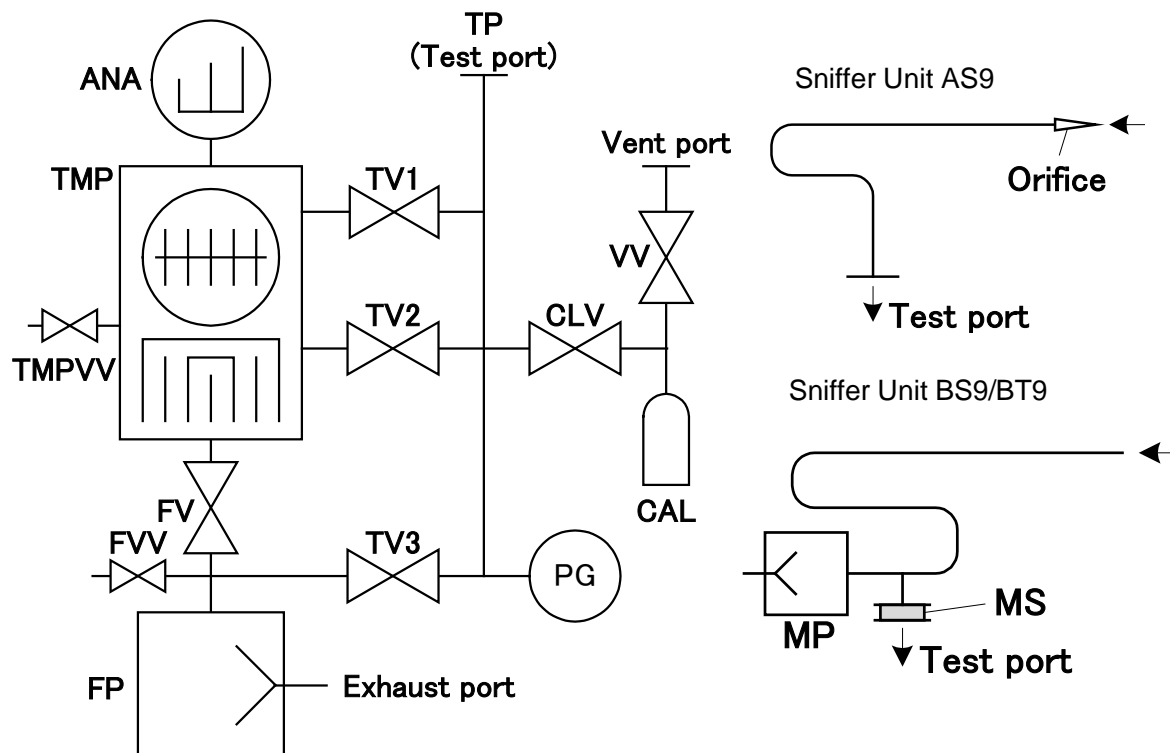

Symbol	Name	Function
TP	Test port	Connects to the test subject or sniffer unit. (NW25)
CAL	Internal calibration leak	Calibration leak of 10^{-8} [Pa · m ³ /s] Calibrated by using the set calibration leak.
CLV	Calibration leak valve	Valve that open when measure the calibration leak and at the atmosphere venting of the process tool.
VV	Vent valve	Valve that vent the atmosphere inner the calibrated leak and in the CLV port.
PG	Pirani vacuum gauge	Observing the test port pressure. Using ULVAC's vacuum gauge (Pirani SPU, Sensor head WP-01)
TV1	Test valve 1	Opens when Ultra leak flow is used.
TV2	Test valve 2	Opens when Fine leak flow is used.
TV3	Test valve 3	Opens when Gross leak flow is used.
ANA	Analyzer tube	90 degrees magnetic field deflection mass spectrometer. 2 filaments (Ir/Y ₂ O ₃) at the Ion-source on board to this analyzer.
TMP	Turbomolecular pump	Pump to exhaust air at test port and analyzer. Pump with He exhaust speed of 31 [l/s].
TMPVV	TMP vent valve	Vents the turbo molecular pump when the instrument stops.
FV	Fore line valve	Fore line valve for Turbo molecular pump which closes during test port roughing.
FVV	Fore line vent valve	Vents the fore line when the instrument stops and at clean up timing.
FP	Fore pump	Functions as a roughing pump for the test port and auxiliary pump for the turbo molecular pump.
MP	Diaphragm pump	Small diaphragm pump, used for probe suction
MS	Microseparator	Creates a pressure differential between the atmosphere.
SP	Sniffer probe	Sucks in atmosphere during Sniffer method test.

1-5 Complex Molecule Pump Unit

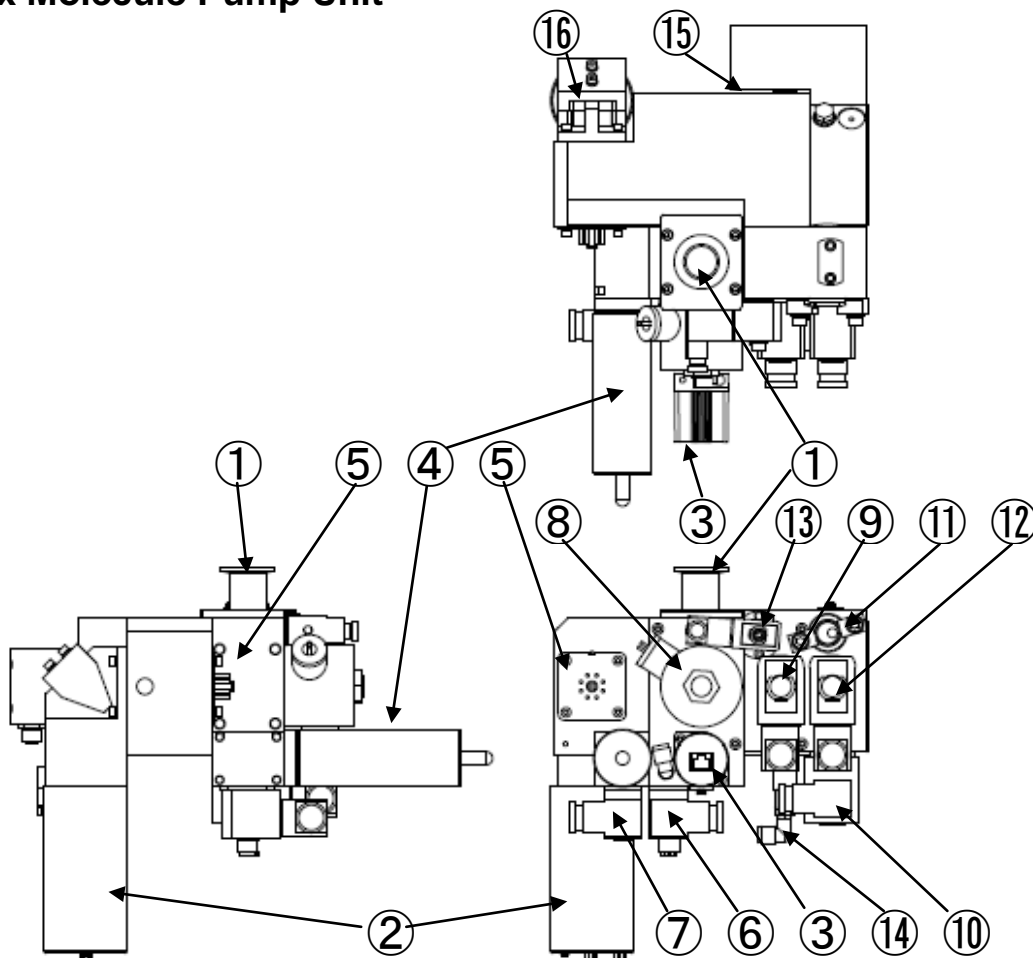

No.	Name	Function
1	Test port	Connects to the test subject or sniffer unit. (NW25)
2	DC amp	Employs circuit to amplify the detected ion current.
3	Pirani vacuum gauge	Observing the test port pressure. Using ULVAC's vacuum gauge (Pirani SPU, Sensor head WP-01)
4	Internal calibration leak	Calibration leak of 10^{-8} [Pa · m ³ /s] Calibrated by using the set calibration leak.
5	Ion source	Ion source. Two Ir/Y ₂ O ₃ filaments are mounted at Ion source of analyzer.
6	Vent valve	Valve that vent the atmosphere inner the calibrated leak and in the CLV port.
7	Calibration leak valve	Valve that open when measure the calibration leak and at the atmosphere venting of the process tool.
8	Test valve 1	Opens when Ultra leak flow is used.
9	Test valve 2	Opens when Fine leak flow is used.
10	Test valve 3	Opens when Gross leak flow is used.
11	Fore line pipe connection port	Connects fore line piping .
12	Fore line valve	Fore line valve for Turbo molecular pump which closes during test port roughing.
13	Fore line vent valve	Vents the fore line when the instrument stops and at clean up timing.
14	TMP vent valve	Vents the turbo molecular pump when the instrument stops.
15	TMP controller	Employs drive circuit of complex molecule pump.
16	Magnet	Magnet to build magnetic field inside the analyzer tube.

1-6 Connector Panel

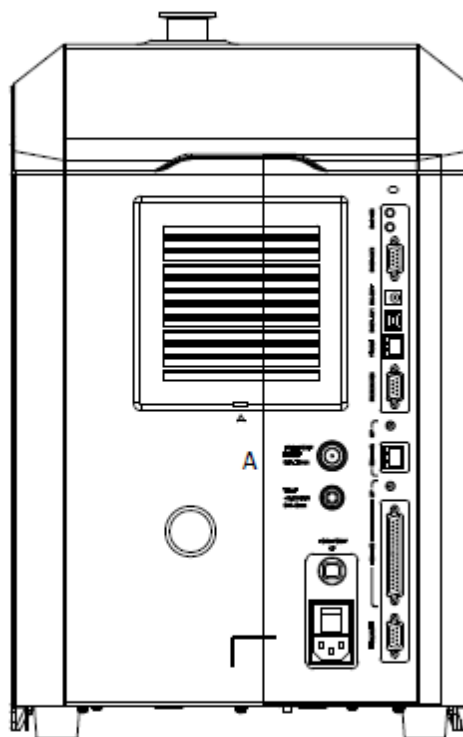
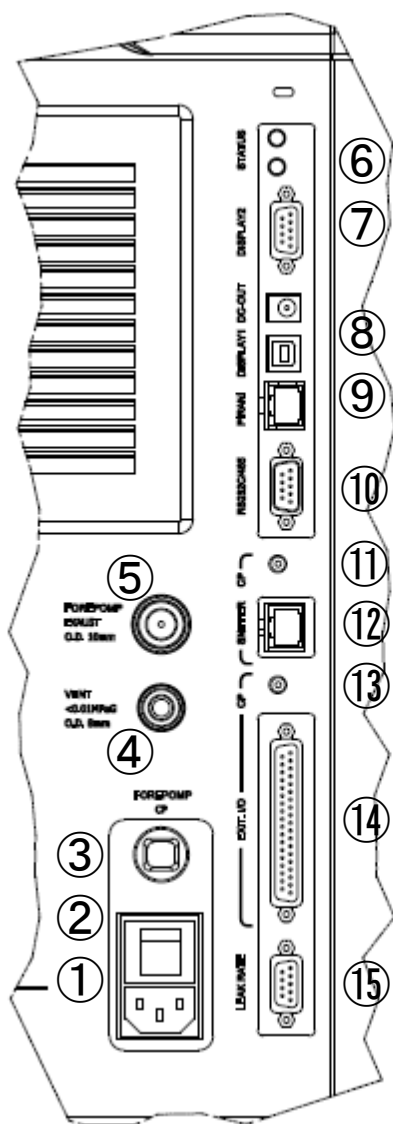

No.	Name	Function
1	AC INPUT connector	Connect the power supply cable to the main unit body.
2	MAIN POWER Switch	Main power switch.
3	FORE PUMP Circuit protector	Shuts off the power when a fore pump malfunction occurs.
4	VENT PORT	Port to vent the gases (example : Nitrogen, Dry air...etc.) to the HELIOT. The tubing size of $\phi 8$. Pressure to be adjusted under 0.01MPa. A filter of 100 μ m is including inner the port.
5	PUMP EXHAUST	Exhaust port of fore pump is connected in 901W1/D2. The port tube size is $\phi 10$. Be careful not to block the port as the pressure rise by the blockage, pump may be broken.
6	STATUS	LED which shows the status of HELIOT. Red : Error , Blue flashing : Start up, Blue lighting : Processing

1. HELIOT 900 Series Specifications and Configurations

No.	Name	Function
7	DISPLAY/RS485	Use to connect by RS485 communication. (D-sub9 male, Inch screw #4-40)
8	DISPLAY/DC-OUT	Use to connect to display as a wired connection.
9	External Pirani vacuum gauge connector	Unused.
10	RS232C communication connector	Use to connect the HELIOT with Thermal printer (PRI-T9) by RS232C or RS485 communication. (D-sub9 male, Inch #4-40)
11	SNIFFER PUMP circuit protector	Shuts off the power to sniffer unit B*9* membrane pump when a malfunction occurs. 1A included.
12	SNIFFER connector	Used to connect the connection cable to the sniffer B*9* unit. (RJ-45 female, Inch screw #4-40)
13	EXT.I/O circuit protector for protecting power supply output	At the using of EXT.I/O, it shuts off the power to PLC when a malfunction occurs. (such as over current flow of more than 2A).
14	EXT.I/O connector	Enables external control and output of set points. (D-sub37 female, inch size screw #4-40).
15	LEAK RATE connector	Outputs voltage that corresponds to the leak rate. (D-sub9 female#4-40).



WARNING

Fore Pump Exhaust Vent

Do not block the fore pump's exhaust vent. It may explode to cause a serious damage to human life or to the manufacturing facility when fore pump exhaust vent is pressurized

2. Set Up

2-1 Unpacking

- 1) Check for any damages to each equipment or outside damage made to the package as soon as you receive the unit even if the equipment is not used right away.
- 2) Check the quantity of components. (The table below corresponds to the standard specification)

List of Standard Specification

Name	Type/Specification	Quantity
HELIOT main unit		1 pc
Tablet		1 pc
Controller cable, 2m set	CONT-SET-CABLE-L2	1 set
Tablet fixing disc		1 pc
Power supply cable	Cable length 5m	1 pc
Operations manual (CD)		1 pc

List of Optional Components

Name	Type/Specification
Sniffer unit AS9	
Sniffer unit BS9/BT9	
Microseparator	
Floor cart (for 901)	CART-91
Controller storage box	CARTBOX-9
Carry case (for 901)	CASE-91
Oil mist trap (for 904W2)	OMTW2
Controller cables, 5 m sets	CONT-SET-CABLE-L5
Controller charger	
Touch pen	PSA-TPA1
Security wire set	AL-29ALM-SLE-1P
Dial lock for security	ESL-NK03
Thermal printer	PRI-T9
Membrane type calibration leak	CLM-07*/CLM-08*/CLM-09*/CLM-10*
Channel type calibration leak	CLC-04A/CLC-05A/CLC-06A
L-type manual valve	VULH-25KF
Helium spray gun	AG50
Connector set	CONNECTOR-91



CAUTION

Hold Horizontally

Do not incline more than 30 degrees when unpacking or moving the equipment and maintain horizontal position during installation.

Failure to do so may result in oil leaks or damage to the equipment.

2-2 Assembling/Moving/Installation

2-2-1 Assembling

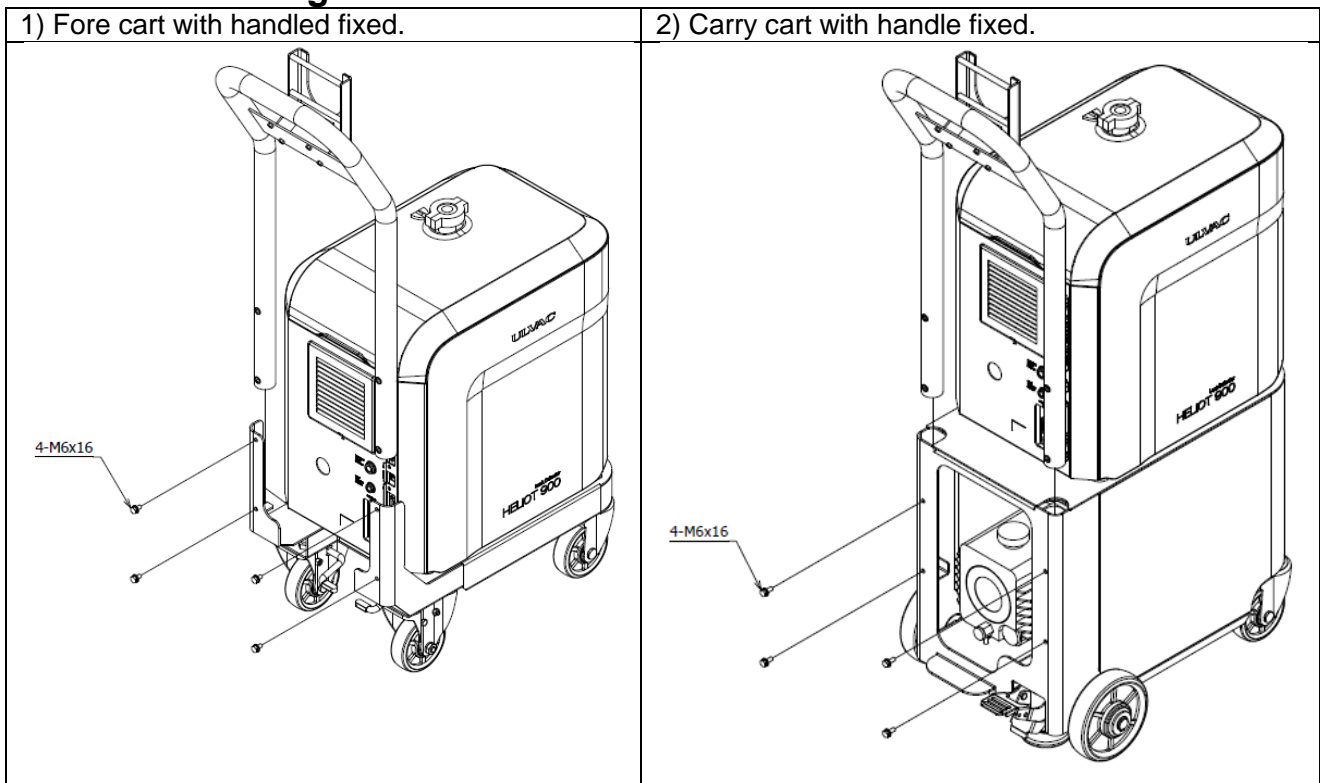

- 1) Push in the handle from the top.
- 2) Secure the handle at 4 areas with attached bolts (M6x16)

2-2-2 Moving/Installation

- 1) Hold the base of the unit when lifting up the portable type. Risk of damage to resin panel when excessive force is applied.
- 2) Use a platform truck when moving portable type (901W1/901D2).
- 3) Install the main equipment on a flat and smooth horizontal surface.
- 4) Make sure not to expose the equipment to vibrations or impacts from the surrounding area.
- 5) When installing HELIOT on a surface such as on a rack, make sure the weight of the equipment is supported by the entire base of the unit
- 6) For portable type with floor cart (optional), make sure the casters are locked. As for mobile type (904W2/904D3/904D4) (with mobile cart), make sure the stopper is locked.
- 7) AC inlet is a shut off device of the equipment. Install so that the connector of power supply cord is easily accessed.

	WARNING	Power Shutdown	When installing the equipment and removing the external panels for servicing and replacement of parts, turn off the Main Power switch and disconnect plug from the outlet before operating. Possibilities of electric shock and damages to the equipment due to high voltage areas.
	CAUTION	Do Not Lift	The construction of this equipment does not provide any eyebolts for cranes. Do not use lifting equipment for transport. Risk of damage to the equipment.
	CAUTION	Watch Your Step	Mounting with floor cart, when moving 904W2/904D3/904D4, there is a danger of crashing your feet. Keep your feet away from the wheels when moving.
	CAUTION	Vibration Prohibited	Do not expose the equipment to vibrations from surrounding machinery or impacts. Risk of damaging the equipment.
	CAUTION	Ensure Ventilation	In order to cool the interior of the main unit, an intake fan is installed on the left panel and an exhaust fan is installed on the right panel. Maintain spacing of 200 mm or more between all panels. Obstructing the vents increases the internal temperature of the equipment to create risk of damaging the equipment.
	CAUTION	Caution to Moisture	Do not use over water or any environment where water drops (water or any liquid). Possibilities of electrical leak and damage to the equipment.
	CAUTION	Ambient Temperature	Operate between ambient temperature of 10°C to 40°C of usage environment

2-3 Connection of Test Port







2-3-1 Vacuum Method

- 1) Connect the attached blank flange (NW25) to the test port.
- 2) Fix firmly with the clamp. (attached when shipped)

2-3-2 Sniffer Method







- 1) Connect the attached Sniffer unit to the test port. When connecting the Sniffer unit BS9/BT9 to the test port, connect with the microseparator. The microseparator is to be attached with the top surface as shown in the photo on the right.
- 2) Fix firmly with the clamp.
- 3) When employing Sniffer method with the Sniffer unit BS9/BT9, connect cable from the Sniffer unit to the connector of the connector panel.



 CAUTION	<p>Pipe Connection When installing pipings or Sniffer unit, check if the flange sheet surface or O-ring are free from scratches and dirt and ensure that it is properly connected. Risk of malfunction if leakage occurs. Additionally, use alcohol to clean any sweat or grease present. Risk of malfunction and possibility of causing damage to the parts.</p>
 CAUTION	<p>Weight on Test Port When connecting pipe fitting to the test port, do not place weights over 50N. Risk of damaging the equipment.</p>
 CAUTION	<p>Foreign substances in Test Port Do not allow any foreign substances such as dirt to enter the test port. Risk of serious impact to the equipment such as leakage and damages to the Turbomolecular pump.</p>
 CAUTION	<p>Use of Blank Flange at Startup (Vacuum Method) Install blank flange to the test port at the time of start up. Starting the equipment with pipings and testing unit connected may result in abnormal operation</p>
 CAUTION	<p>Use of Sniffer Unit (Sniffer Method) Install the Sniffer unit to the test port at the time of startup. If Sniffer unit B is used, connect cable to connector panel. The Sniffer unit will not operate and cause abnormal operation if it is not connected.</p>
 CAUTION	<p>Microseparator (Sniffer Method) When connecting Sniffer unit B to the test port, make sure that the auxiliary microseparator is securely connected as an O-ring. If used without connecting the microseparator, it may lead to damage of the equipment. The microseparator has a proper installation orientation. Pay special attention to the correct orientation when installing.</p>
 CAUTION	<p>Sniffer Probe (Sniffer Method) Special care is needed for handling of the Sniffer unit. The probe may damage if excessive force is applied.</p>

2-4 Electrical Connections

- 1) Make sure the MAIN POWER switch on the main unit is OFF
- 2) Connect the power supply cable to the AC INPUT connector on the main unit's connector panel.
- 3) Plug in the power cable to a power supply outlet. In order to prevent earth leakage, always ground the equipment with class 1 equipment.

 WARNING	Power Shutdown When installing the equipment or removing external panels to inspect and replace parts, turn the MAIN POWER switch OFF and remove the power supply plug from the outlet before working. High voltage areas are present in the equipment which may cause risk of electric shock and damage to the equipment.
 WARNING	Verification of Power Supply voltage The rated voltage of the equipment corresponds with the local power supply voltage must be verified before connecting the equipment to power supply. The rated voltage of this equipment can be found on the name plate of back panel of the equipment. The setting of this power supply voltage cannot be changed.
 WARNING	Power Supply Cable Always verify that the power supply cable supplied with the unit exceeds the equipment's rating before use. Risk of fire from using power supply cable with lower ratings than that of the equipment's.
 WARNING	Input Power Supply Cable As for the rated voltage, input a voltage at $\pm 10\%$ the voltage listed on the name plate. See Section 1-2 for the rated current. Before supplying power, always verify the supply side voltage/permissible current. May result in risk of human life or serious damage to manufacturing facility
 CAUTION	Grounding In order to prevent earth leakage, always ground the equipment with a class 1 ground using the power supply plug ground wire. Since this is a Class 1 equipment in Europe and North America, always ground with power supply plug ground wire.
 CAUTION	Electrical Connections Connect all electrical wirings after completing installation.

2-5 Storage

Be aware of the following items when storing HELIOT 900.

- Store in an ambient temperature between 10°C to 40°C, ambient humidity between 35 to 85 %. There are components that may cause malfunction within the equipment.
- Do not store in dirty or dusty locations. If dirt or dust penetrates inside the unit, there is a risk of short circuit in the electrical system.
- If dirt or dust penetrates inside the test port or stay on sheet surface of the valve and results in leakage of the equipment. This may lead to decrease in reliability of measurement value and abnormal completion of startup. Additionally, store the equipment with a blank flange installed to the test port. Failure to do so may lead to failure of the pump used in the equipment.
- When the equipment does not startup properly, you may need to repeat startup several times.

3. Operation Overview

3-1 Power Supply ON – Testing – Till Stop

HELIOT can be divided into 5 modes of “Preliminary mode”, “During activation”, “Standby/Test” “Under Stop” and “Error”. The explanations of the operation are given as follows.

3-1-1 Power Activation

Turn on the MAIN POWER of main unit connector panel (section 1-6) and tablet power supply (Section1-3-2_1)). The tablet will complete the software in about 60 seconds and initial screen displays after long press of the power supply switch.



CAUTION

Input Switch

Press the tablet switch with pad of your finger. Pressing with finger nails or sharp objects may cause damage.

3-1-2 Preliminary Mode

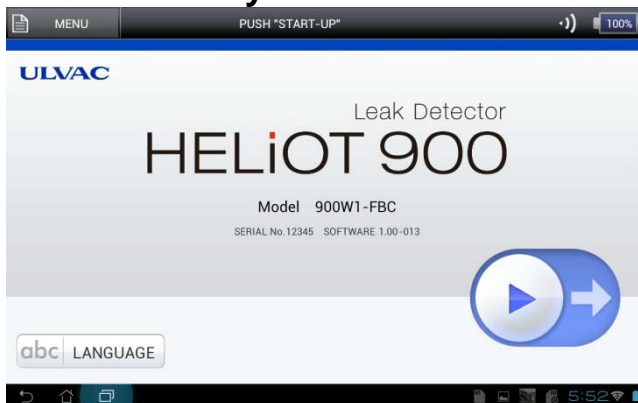

English is set at the time of shipment from manufacturer. To change language, press **LANGUAGE** to show the language window and select your choice of language. (Japanese, English, German, Chinese, Korean, Formosan, Spanish)

Slide the start button  , to start.

*When employing Sniffer method, set the test mode as Sniffer (**) using [MENU] – [SETTINGS] – [GENERAL]. For details refer to setting method Section 5-1_2).

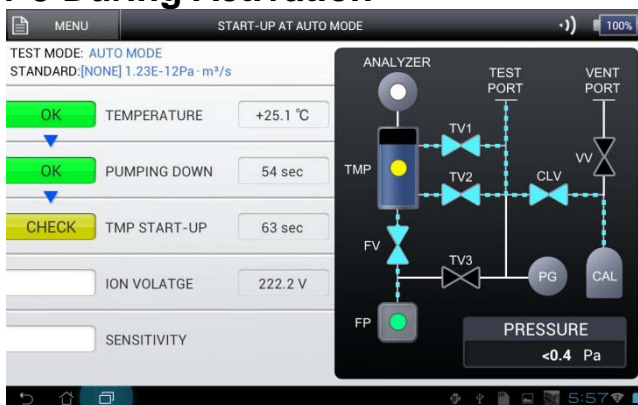

3-1-3 During Activation

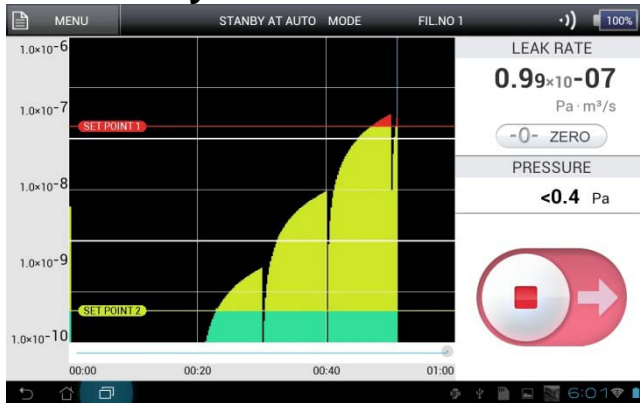

To ensure the equipment has no abnormality, the following sequence is followed. Verification of internal temperature of the equipment – exhaust system (roughing) – exhaust system – (TMP) – adjustment of analyzers – sensitivity calibration – startup completion. After startup completion, it changes to test screen. For details refer to section 7.

3-1-4 Standby/Test



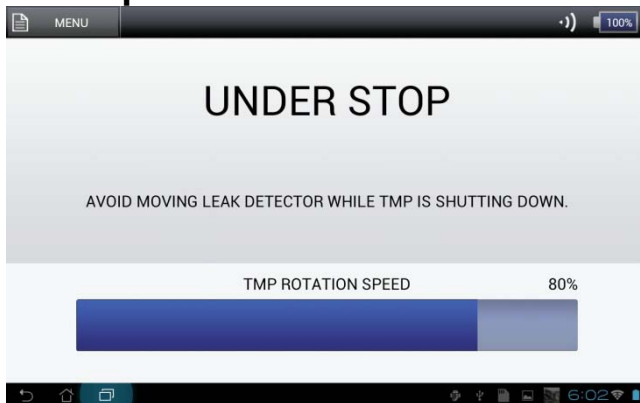

Connect test port to test units under standby mode. When you slide  roughing begins and when it reaches to a specific pressure, then measurement begins. When you slide , measurement terminates.

3-1-5 Stop



By pressing [MENU] - [SHUTDOWN] and YES, Turbomolecular pump showing its rotation speed displays on the stop screen. In about 1 minute, the stop mode completes to change to preliminary screen. Before changing to the preliminary screen, do not move the main unit or expose to vibrations or impacts.

 CAUTION	Stop Execution To stop the equipment, use indicator, EXT.I/O and serial communication to execute stop
 CAUTION	During Stop When the stop operation is executed, the Turbomolecular pump rotation speed is displayed. Before changing to the preliminary screen, do not move the main unit or expose to vibration or impact. Risk of damaging the equipment.

3-1-6 Errors



Error screen is displayed when any abnormal condition arises. Depending on the error the equipment recovers from the error or automatically stops.

 CAUTION	Errors In the event of an error, release error mode after checking the error message. See the troubleshooting section and service/repair as necessary.
---	--

3-1-7 Power Supply OFF

Turn OFF the MAIN POWER of main unit connector panel (Section 1-6). Press power supply of tablet Section 1-3-2 1) for 2 seconds to shutdown. Additionally, by pressing the power supply button for 0.5 second, it can also be changed to sleep mode.

3-2 Window Screen Operations

Window screen operation is required in modification of setting screen. The following illustrates a few basic examples.

Example 1. Window type selection buttons

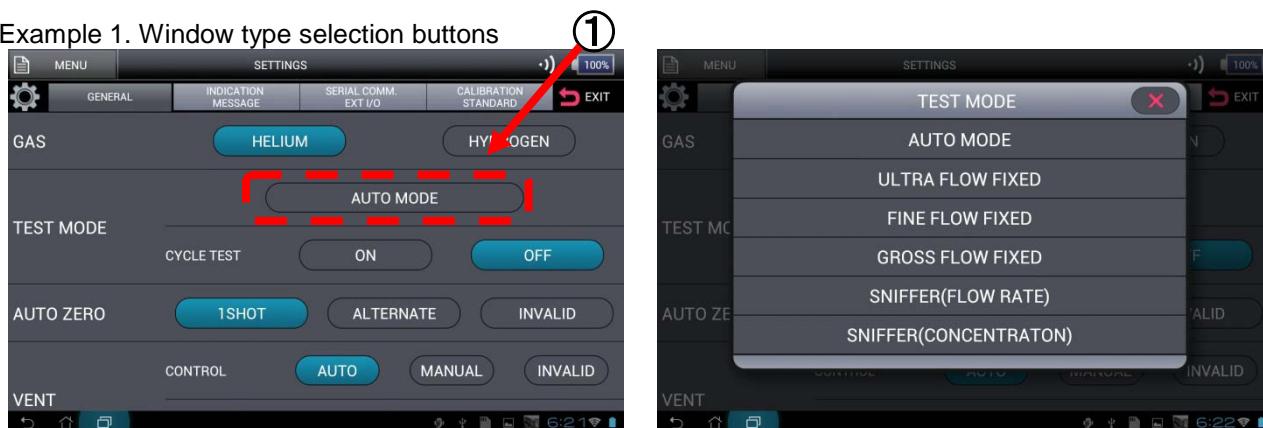

The screen above shows AUTO MODE as an example. To start, press the button and the window screen (screen at right) displays. Select and press one of the buttons from the multiple buttons displayed in the window screen, which then closes the window screen to complete the selection.

Example 2. Window type numeric keypad buttons

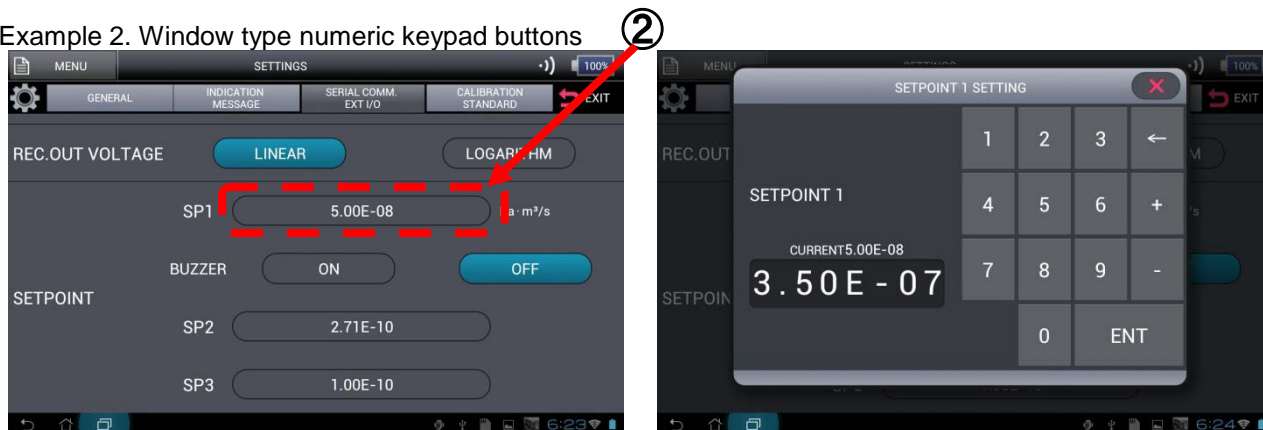

Numeric input items such as 2) shown above, have these numbers entered with the window numeric keypad buttons. First press the display, then the numeric keypad appears as per the photos above. Use this numeric keypad to input numeric values. (The right photo shows the order to which you press 3, 5, 0, ., 0, 7). After entering the numbers, press ENT. If you cannot press ENT, your input of numeric values are incorrect. Be aware that if X is pressed without pressing ENT, the value will not be set.

This completes the setting and closes the numeric keypad buttons.

3-3 MENU Screen

Turn on the MAIN POWER switch ON. Then the MENU screen will be accessible during the following modes: initial screen, standby, after completion of startup, testing.
Depending on the condition of the equipment valid buttons will vary

1) Initial Screen

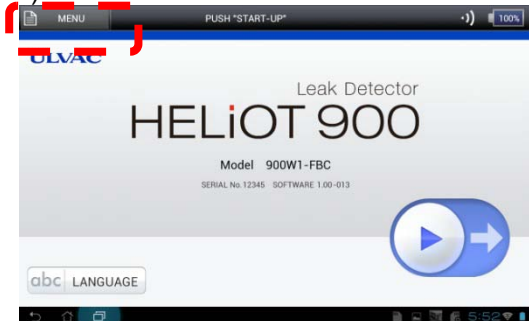

Long press **MENU** for 3 seconds.
(Startup and test screens and all the other screens have the **MENU** on the same position.)

2)-1 MENU (Initial screen)



2)-2 MENU (Standby)



2)-3 MENU (Testing)



2)-4 MENU (startup)



- 1) **SETTINGS**: Changes to setting screen (Section 5)
 In setting mode [General] – [Operation lock] - **VALID** - changes to 3). pass word input screen
 In setting mode [General] – [Operation lock] - **INVALID** changes to 3) MENU screen. (Section 5-1_11)
- 2) **INFORMATION**: Changes to information screen. (Section 6)
- 3) **LANGUAGE**: Changes to language change screen.
- 4) **NETWORK**: Detects connecting point of wireless LAN. (Section 4)
- 5) **CAL.START**: Repeats sensitivity calibration. (Section 8-5)
- 6) **CAL.CHECK**: Automatically checks the open/close of built-in calibration leak. (Section 8-6)
- 7) **CLEAN UP**: Executes clean up. (Section 8-4)
- 8) **SHUTDOWN**: Executes equipment stop. (Section 3-1-5)

3) Password

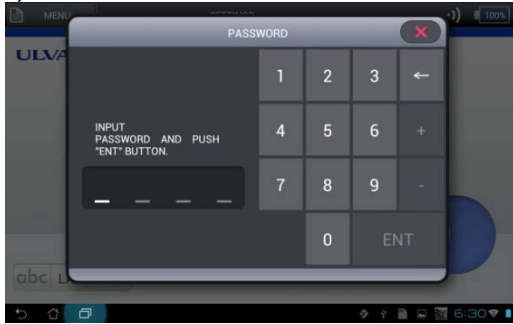

Input password using numeric keypad.

(Initial value of password is 0000)

Press **ENT** after entering numeric value. Pressing **X** before pressing **ENT** will return to a screen before pressing MENU.

If password is correct, the screen changes to setting modification screen.

If password is incorrect, it returns to a screen before pressing MENU and indicates as PASSWORD ERROR.

If password is forgotten, entering password 9999 will change to setting screen. Then check the password.

4. Connection of Main Unit and Tablet

4-1 Wire Connection

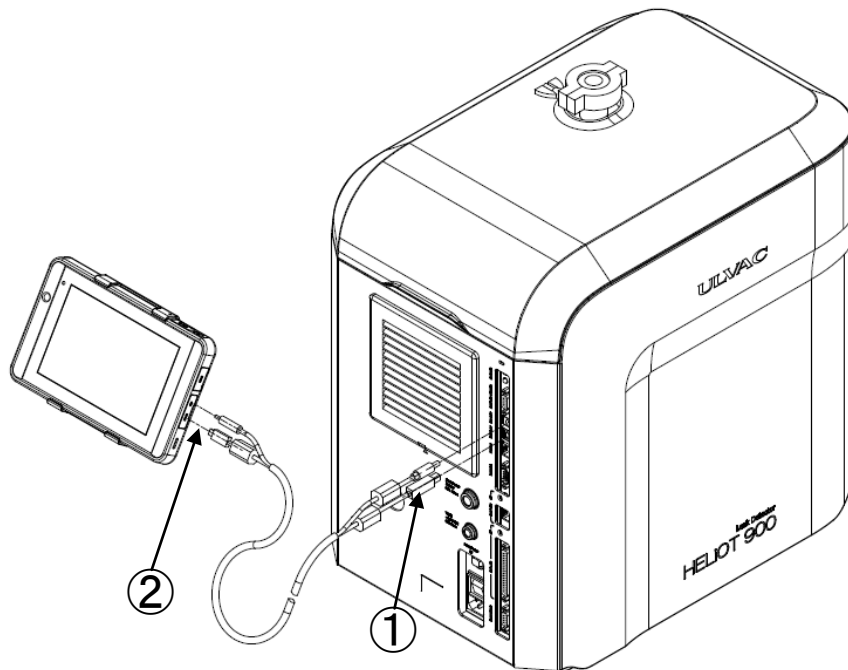

- 1) Connect the accompanying cable to DISPLAY and DC-OUT of the main unit connector panel.
- 2) Connect the accompanying cable to Mini USB connector and DC input jack of the tablet.
- 3) Turn ON the MAIN POWER of main unit connector panel (Section 1-6) and power supply (Section 1-3-2 1)) of tablet. The software activates in approximately 60 seconds and initial screen displays.
- 4) If the screen below is displayed, press **RETRY** button and then execute the connection again.

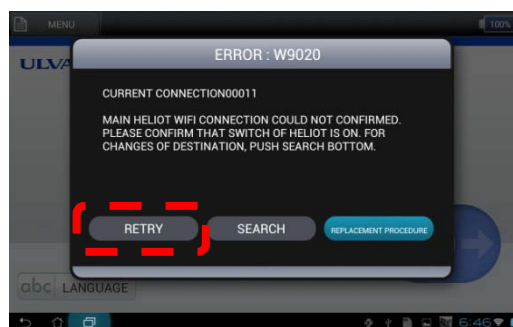

4-2 Wireless Connection

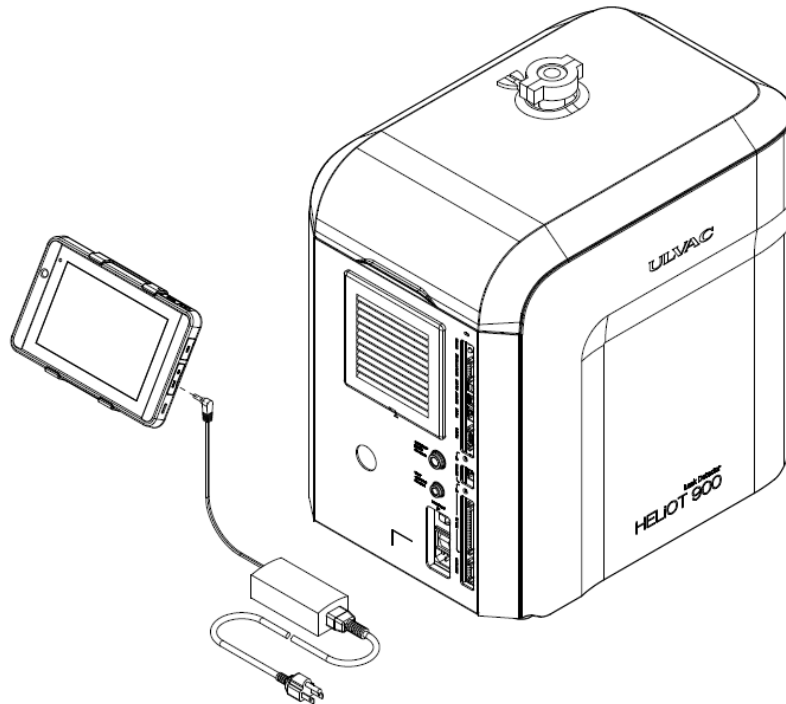

CAUTION

2.4GHZ Band Wireless Equipment

This equipment is installed with 2.4GHz band wireless function compatible to standard IEEE 802.11b/g/n. Refer to nation/local laws for use.

- 1) When using the tablet while charging, connect to DC input jack through optional controller charging unit.
- 2) Turn ON the MAIN POWER of main unit connector panel (Section 1-6) and power supply (Section 1-3-2 1)) of tablet. The software activates in approximately 60 seconds and initial screen displays.

4-2-1 When Reconnecting

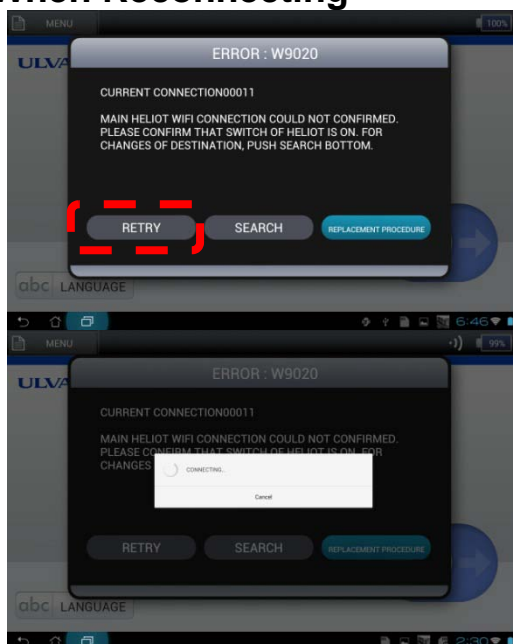

- 3) When reconnecting with the equipment, press the **RETRY** button in the photo on the left screen and execute reconnection.
- 4) When executing 3) "CONNECTING" screen displays.
- 5) Initial screen displays when connection is completed.
- 6) In case of connection failure, verification of connection point of the equipment and resetting of connection point is required. (Section 4-2-2)

4-2-2 When Resetting Connection Point

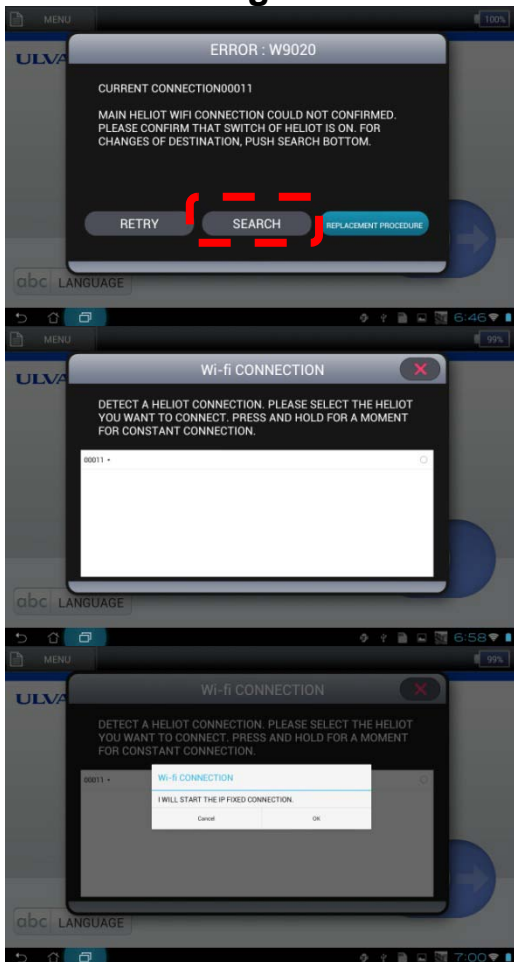

- 3) In case of failure in modifying equipment's connection point and connection using **RETRY** button, press **SEARCH** button and check if there are any equipment available for connection.
- 4) When **SEARCH** is executed "Searching Connection Point" displays on the screen and if there are any equipment available for connection afterwards, the left screen displays.
- 5) If the connection is for single use, select equipment's serial number. If connection is always a priority (fixed), long press.
- 6) If selection is made in 5), left screen displays and when the connection is completed, it displays the initial screen.

5. SETTINGS

This Section explains various setting that can be changed according to your work conditions. The set value entered are recorded in the main unit of the equipment, therefore, once the equipment is set, it will also operate under the same conditions each time it is used.



CAUTION

Input Switch

Press the tablet switch with your finger pad. Pressing with finger nails or sharp objects may cause damage.

5-1 GENERAL

General screen displays first on the modification set screen.

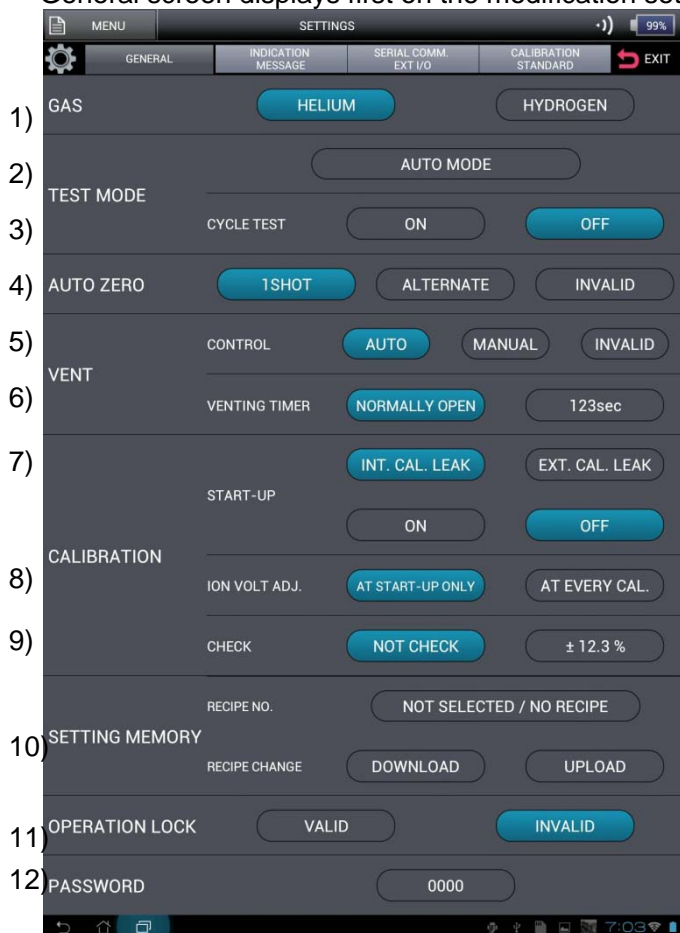

- 1) [GAS]
Select HELIUM (He) or HYDROGEN (H₂).
After completion of startup, settings cannot be changed.
- 2) [TEST MODE]
Select the test mode used for measurement. Refer to Section 8-2 for difference of test flow.
- 3) [TEST MODE/CYCLE TEST]
Test 1 cycle (roughing, B.G. monitor, He spray signal/HeV output/up to judgment of acceptance) can be automatically performed.
With the test mode setting, when Ultra flow, Fine flow and Gross flow are selected, cycle test setting can be set to ON. Refer to Section 8-2-1 for details.
- 4) [AUTO ZERO]
During testing, long press **-0-ZERO** over 3 seconds to change zero point so that the instant leak rate becomes "0.0₁".
In case of **1SHOT** mode, after each long press **-0-ZERO** of 3 seconds, zero point is updated. In case of **ALTERNATE** after each long press **-0-ZERO** of 3 seconds, zero point is updated.
When in **INVALID** mode, no update is executed.
Under normal conditions, **1SHOT** setting is recommended. Refer to Section 8-3 for details.

5) [VENT/CONTROL]

The following explains setting of Vent control method after completion of testing.

When in [AUTO] mode, vent is executed immediately after completion of testing. Therefore, atmosphere is injected into chambers connected to the test ports.

When in [MANUAL] mode, test start/stop button switches with vent button after completion of testing. Testing is completed however, vent valve will not open. Therefore, chambers connected to the test port maintain vacuum.

When in [INVALID] mode, control of any vent valve is not executed. (Vent valve will never be opened)

If the chambers connected to the Test Ports need to maintain vacuum even after the completion of testing, select [MANUAL] or [INVALID]. Except when cycle test is used, it will be [AUTO] on a mandatory base. Refer to Section 8-2-1 for cycle test. When controlling the equipment under EXT.I/O (Section 11-1), set at automatic vent.

6) [VENT/VENTING TIMER]

Sets vent opening time.

When in [NORMALLY OPEN] mode, close vent control is not executed, but maintains open status.

When time is set, after the set time has passed, opens the valve.

7) [CALIBRATION/START-UP]

Selection of calibration leak used at the time of startup and set the condition of sensitivity calibration.

When [INT. CAL. LEAK] is selected, the calibration leak installed in the equipment is used for startup of the equipment.

When [EXT. CAL. LEAK] is selected, the calibration leak prepared at the outside of the equipment is used to start the equipment. When external calibration leak is selected, external calibration leak valve setting will be required.

When Sniffer (concentration) is selected in the test mode of 2), buttons are switched to [ATM], [STD. GAS]. Select startup method of Sniffer method

Additionally, in [ON] mode, sensitivity calibration is executed at the time of startup.

When in [OFF] mode, it starts without executing sensitivity calibration. The startup will complete within a few minutes, however the sensitivity applies data of the previous sensitivity test, therefore, there is a risk of obtaining unsuitable data. After completion of the startup, it is recommended to verify if the appropriate measurement value has been obtained, e.g. by sucking in calibration leaks. Even if [OFF] is selected, sensitivity calibration may execute under the following conditions.

- When there is no sensitivity data.
- When error occurred at the last startup
- When filament break occurred.

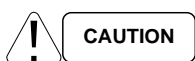
**Startup Without Sensitivity Calibration**

Irrespective of the equipment's condition, startup without sensitivity calibration uses previous calibration data without any change which may cause large tolerance in measurement value. In order to obtain more reliable data, it is recommended to execute sensitivity calibration.

8) [CALIBRATION/ION VOLT ADJ.]

Accelerated voltage adjustment condition is set.

When in [AT START-UP ONLY] mode, the accelerated voltage adjustment is limited to execution period of sensitivity calibration only.

When in [AT EVERY CAL.] mode, accelerated voltage adjustment is executed during startup/sensitivity re-calibration and during all sensitivity calibration

9) [CALIBRATION/CHECK]

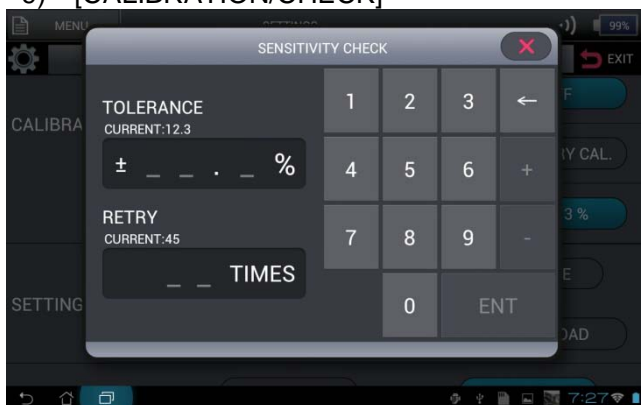

When in [NOT CHECK] mode, startup is completed without sensitivity check.

When $\pm 12.3\%$ is selected, after completion of sensitivity calibration, calibration check by recalibration leak measurement is executed. If sensitivity is not found in [TOLERANCE] of the setting window on the left, repeats sensitivity calibration with the number of times set in [RETRY] until it becomes within [TOLERANCE].

Irrespective of within/outside the [TOLERANCE], result of the measured tolerance is displayed after completion of start up. Check the display and determine whether to continue or stop the equipment and restart.

Additionally, if sensitivity recalibration is executed during with-sensitivity check mode, it always executes calibration check and if it is within [TOLERANCE], returns to test mode without executing sensitivity calibration. If not in [TOLERANCE], as in the startup, executes sensitivity calibration and then, re-execute the check.

* Cannot be used when in Auto flow, Sniffer flow, hydrogen measurement mode and external calibration leak setting.

10) [SETTING MEMORY/RECIPE. NO./RECIPE CHANGE]

Executes Memory/Setting of setting details.

Maximum of 5 setting patterns can be controlled under RECIPE No. from 1 to 5. It would be useful when different settings are required for inspection line. To store setting details, install recipe number under RECIPE No. and press [DOWNLOAD] of setting data. For SETTING past settings stored, select the recipe number that you want to SET with RECIPE NO. and press [UPLOAD] of data setting.

Recipe is stored in micro SD card, then insert it into the micro SD card slot.

If no micro SD card is found in the micro SD card slot, error will show when setting and storing.

11) [OPERATION LOCK]

If this setting is made [VALID], it will neither be possible to change display range on the test screen nor to operate auto zero.

Additionally, in order to avoid change of setting contents by error, a screen to input password will be shown before moving on to setting modification screen.

12) [PASSWORD]

When the operation lock of Section 11) is set [VALID], set a password value under password request screen.

The default value is set at 0000. When changing it, select password display and input 4 digit numbers.

5-2 INDICATION/MESSAGE

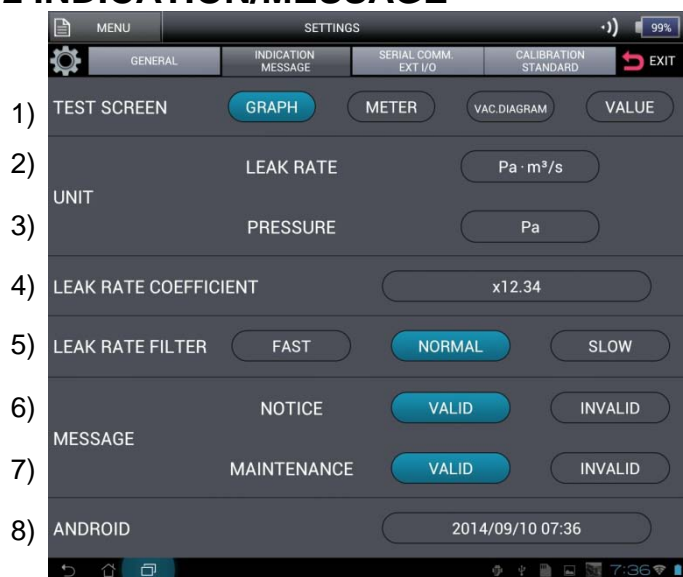

- 1)
- 2)
- 3)
- 4)
- 5)
- 6)
- 7)
- 8)

1) [TEST SCREEN]

Select test screen. 4 types of test screens are available, graph, meter, vac. system and value.

Choose your preferred test screen.

2) [UNIT/LEAK RATE]

Select a leak rate to show on the test screen.

If Pa·m³/s, mbar·L/s, Torr·L/s and atm·cc/s are chosen as units, their pressure units of Pa, mbar, Torr and atm will be automatically shown. If other units are chosen, the pressure unit will be unchanged.

ppm unit can be set when selecting Sniffer concentration during test mode.

3) [UNIT/PRESSURE]

Select pressure unit to show on the test screen

4) [LEAK RATE CORRECTION]

This is valid when multiplying coefficient for displaying leak rate. When using this setting, values except x01.00 can be entered

Valid when changing gas concentration of He gas or measuring operational exhausts.

<Example of use>

When using 5% of gas, $1/0.05=20.00$ is to be entered. Since the display value will be 20 times, its corresponding value (expected leak rate when the gas concentration is 100%) when using 100% gas will be displayed.

5) [LEAK RATE FILTER]

Filter setting against the leak rate display of test screen.

This filter uses ULVAC's unique algorithm for filtering. By using this filter, steady display of background is maintained under a reduced He condition. However, its response will be delayed.

Under **FAST** setting, indication of no filter is displayed.

Under **NORMAL** setting, it is displayed with standard filter.

Under **SLOW** setting, more stable display than NORMAL is possible with high-capacity filter.

When stable display is required, set to **NORMAL** or **SLOW**.

When response is prioritized as in the case of ALT system, **FAST** setting is recommended.

6) [MESSAGE/NOTICE]

A display setting during startup when minor abnormal* condition is detected. CAUTION screen will appear only when **VALID** is selected. Additionally, outputs ERROR2 signal with connector panel EXT.I/O connector PIN-7. (Section 11-1)

If **INVALID** is selected, the CAUTION screen is skipped and moves to TEST screen, but flashes a CAUTION error indicator on the status area at the screen top. Except for inevitable mandatory completion of startup, execute automatic setup by using EXT.I/O of external input/output signal and recommend to select **VALID**.

*Minor abnormal conditions are those do not lead to damage of the equipment. Rechecking of sensitivity by executing sensitivity recalibration is recommended. Even when **INVALID** is selected, the history remains in the error history (Section 6-5) which can be checked.

- 7) [MESSAGE/MAINTENANCE]
 Displays periodic maintenance information screen at an appropriate interval. For preventive maintenance, except for inevitable mandatory completion of startup, execute automatic setup by EXT.I/O of external input/output signal and recommend to select **VALID**. Even when **INVALID** is selected, maintenance elaps period indicator flashes on the status area at the screen top.

- 8) [Android]
 Selecting the time display area allows you to enter into Android setting screen. Except for the following 1) to 4) settings, do not make any changes. By changing the settings, it may stop operation.

When setting is completed, move to HELIOT setting screen by left bottom  mark.

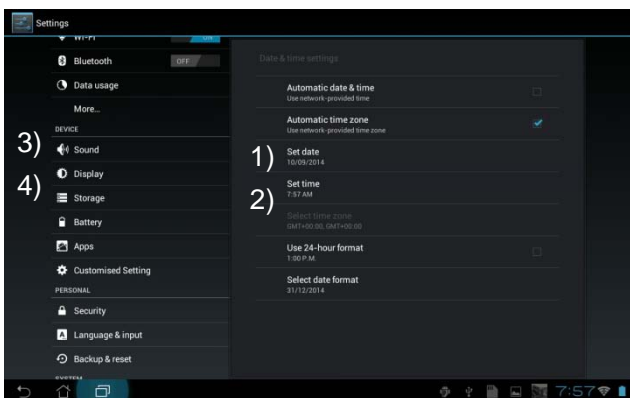

Screen with 3) selected

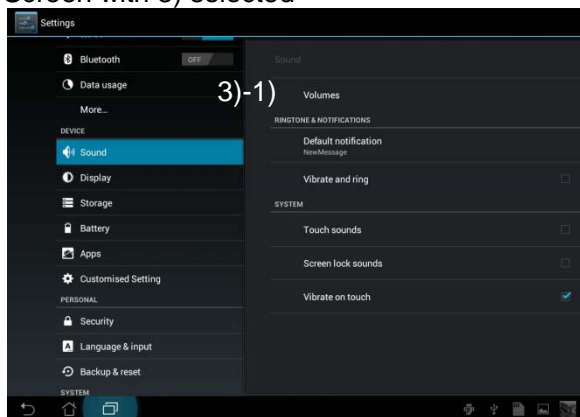

Screen with 4) selected

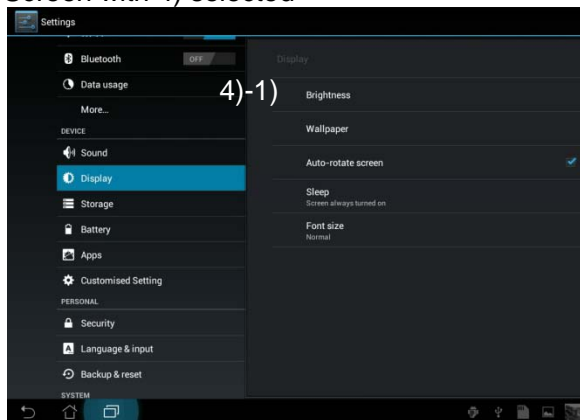

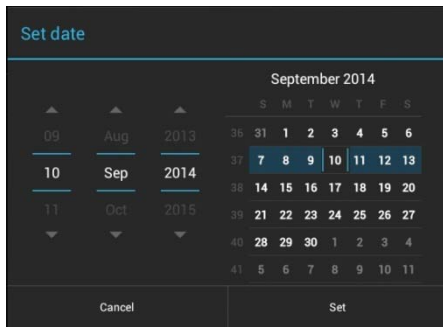

8)-1) [Set date]

This sets the date stored in the tablet. Check if the setting is correct because this date will be used as data of sensitivity calibration period during startup of the equipment.

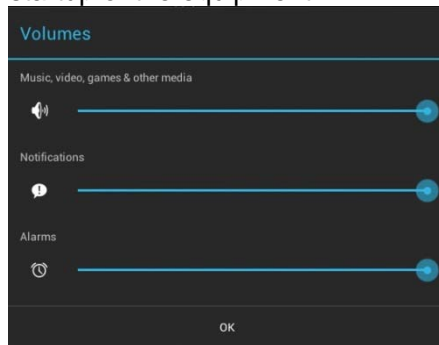

8)-3)-1) [Volumes]

This sets the volume of audio alarm. Battery life varies according to the sound volume. Suitable volume is to be set.

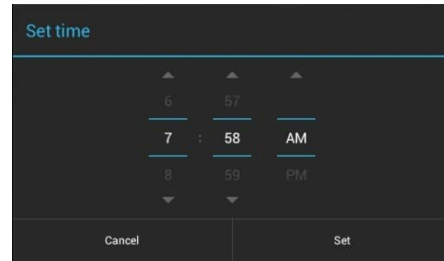

8)-2) [Set time]

This sets the time stored in the tablet. Check if the setting is correct because this time will be used as data of sensitivity calibration period during startup of the equipment.

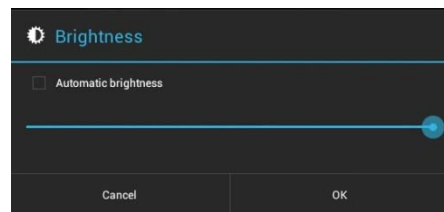

8)-4)-1) [Brightness]

This sets the brightness of screen. Battery life varies according to the brightness of screen. Suitable brightness is to be set.

5-3 SERIAL COMM./EXT I/O

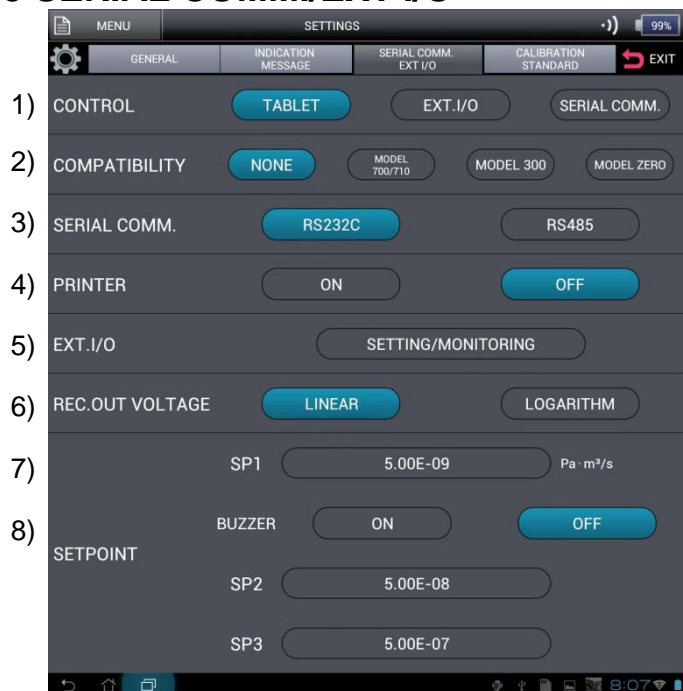

1) [CONTROL]

This sets the control method of equipment.

In case of [TABLET] setting, input signals except EXT. I/O clean up (30pin), IND.HOLD (29pin), auto zero (26pin), Peak Hold (31pin) and PRINT (27pin) will be invalid.

However, when cycle test is selected under (Section 5-3-1), 1 cycle test will be conducted by TEST START/STOP (21 pin) pulse input of EXT. I/O input signal.

In case of [EXT.I/O] setting, start/finish of tablet test, signals are valid except for CLEAN UP AND SHUTDOWN within the menu.

In case of [SERIAL COMM.] setting, start/finish of test, CLEAN UP AND SHUTDOWN, others are valid.

Signals except external I/O clean up (30pin), IND.HOLD(29pin), auto zero (26pin), Peak Hold(31pin) and PRINT(27pin) will be invalid.

After completion of startup, settings are not permitted to be changed.

2) [COMPATIBILITY]

This sets the compatibility.

In case of [NONE] setting, it will be set as MODEL 900 setting. If other MODEL 710/700, MODEL 300 and MODEL ZERO are selected, communication command and recorder output will be modified to maintain compatibility.

After completion of startup, settings are not permitted to be changed.

3) [SERIAL COMM.]

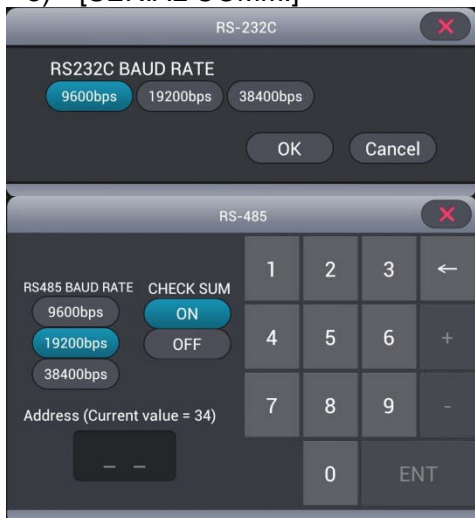

This sets various setting for communication.

When communication setting part of **[RS232C]**, **[RS485]** are selected, popup displays as on the left screen.

<RS232C/RS485 BAUD RATE>

Set the baud rate. Baud rate allows settings of **[9600bps]**, **[1920bps]**, **[38400bps]**.

<RS485 CHECK SUM>

[ON] : receives the HOST-side DATA checksum value, collates it with command DATA. The result of collation, when an error occurs in sending/receiving DATA, is returned as “n” and the operation corresponding to the command is not performed. If the collation result matches, the operation returns accordingly.

[OFF] : receives the HOST-side DATA checksum value, but does not collate it with command DATA.

Whatever the checksum's DATA is, so long as the command matches, the operation returns accordingly.

(Can communicate with the HOST-side DATA checksum value fixed as “00”)

<RS485Address>

Setting rang is between 1 and 99 (00 is prohibited to use). However, the maximum number of nodes in a single line is 32 including the host.

4) [PRINTER]

Startup DATA and measurement value may be printed with optionally sold printer. When printer setting is set to **[ON]**, sensitivity under each flow is automatically printed at the time of startup completion.

Additionally, test measurement value is automatically printed when test is completed. Each time leak rate display part is pressed during testing, measurement value at a given point can also be printed. When printer selection is set to **[OFF]**, automatic printing stops. As for the connection of printer and operation, refer to (Section 11-3).

When using printer, set communication set the setting of Section 5-3_3) and RS232C, baud rate to 9600bps for use.

5) [EXT.I/O]



Execute setting/output of EXT.I/O.

When **[SETTING/MONITORING]** is selected on the screen, a pop up to check Input/output is indicated as in the left screen

<EXT.I/O INPUT HELIOT←>

When input signal is received from sequencers, etc. the assigned lamp lights up.

<EXT.I/O OUTPUT HELIOT→>

Output setting of N.O (NORMALLY OPEN) and N.C (NORMALLY CLOSED) can be performed on each signal.

When a button which is assigned against each output signal is pressed, the connector of the equipment EXT.I/O outputs signal.

The HELIOT should be in status before start-up when ON/OFF output signal from HELIOT to sequencer is required to check.

<REC.OUT HELIOT→>

Pseudo output of 0 to 10V recorder output is possible.

The HELIOT should be in status before start-up when ON/OFF output signal from HELIOT to sequencer is required to check. By selecting voltage display areas of 2, 3 and 4 and entering voltage, it outputs the voltage value set by the pin.

To check this output, it outputs against leak volume after the startup, therefore, it can only be used when the equipment is at a stop

6) [REC. OUT VOLTAGE]

Set the configuration of the recorder output

Sets to Linear output when **[LINEAR]** is selected.

Sets to LOG output when **[LOGARITHM]** is selected. Refer to Section 12-2 for details.

7) [SETPOINT SP1/SP2/SP3]

Press numerical areas to set each setting point. When leak rate exceed set value of SP1 during the test, graph or numerical values change to red.

In addition when leak rate exceed SP2 set value during the test, graph or numerical values change to yellow.

By setting $SP1 > SP2$, it becomes to the above colored graph or numerical values.

By setting $SP1 > SP2$, it becomes red of SP1 only.

The output signal from connector of connect panel EXT.I/O in Section 11-1 is turned ON (contact is OPEN→CLOSE) (at normally opened). Lamps and bells connected outside may be used as judgment of acceptance for leakage test. As for the judgment value of set point bell, cycle test, SP1 is applied. For B.G. monitoring judgment of the cycle test, SP2 is applied.

8) [SETPOINT BUZZER]

This is the setting to use set point alarm. While **[ON]** is selected during the test, intermittent alarm sounds before leakage rate exceeds the set value of SP1, when it exceeds SP1, continuous audio alarm sets off. Refer to Section 5-2 8)-3)-1) for volumes of the alarm clock.

5-4 CALIBRATION STANDARD

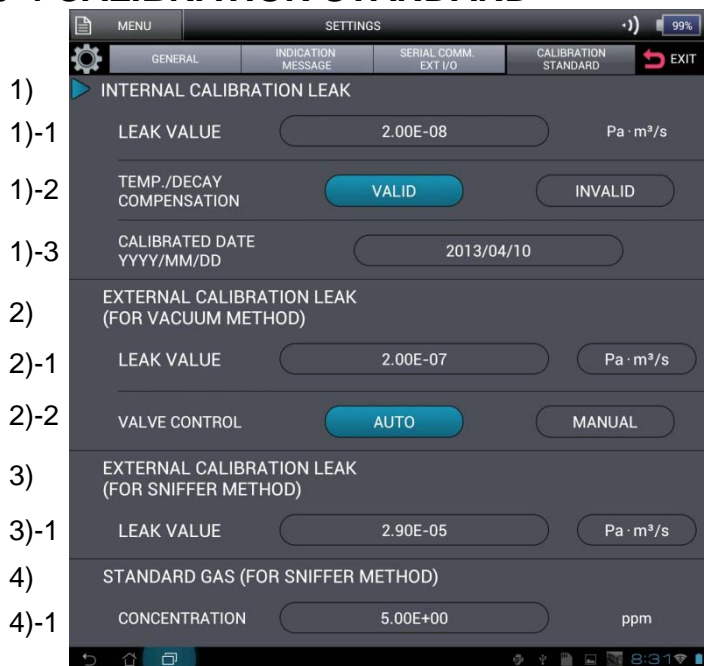

- 1)
- 1)-1
- 1)-2
- 1)-3
- 2)
- 2)-1
- 2)-2
- 3)
- 3)-1
- 4)
- 4)-1

- 1) [INTERNAL CALIBRATION LEAK]
- 1)-1 [LEAK VALUE]

Built-in calibration leak rate is set at the time of shipment. If the built-in calibration leak rate is changed by recalibration of the built-in calibration leak, press numerical area on the screen and re-enter suitable calibration lead value. Settings cannot be changed after completion of startup.

- 1)-2 [Temp./DECAY COMPENSATION]

For Temperature correction due to tube surface temperature of calibration leak and secular change correction of calibration date, **VALID** setting is used. In case above corrections are not executed **INVALID** setting is used.

(Compensation coefficient is for reference value only. The compensation coefficient is not measured individually.) Settings cannot be changed after completion of startup.

- 1)-3 [CALIBRATED DATE]

Enter calibration date of calibration leak. The calibration date of calibration leak is indicated on the name plate of the calibration leak. Enter the date in dominical year. The calibration leak value is automatically corrected by setting the current date and aforementioned secular change correction value.

Settings cannot be changed after completion of startup.

- 2) [EXTERNAL CALIBRATION LEAK (FOR VACUUM METHOD)]

- 2)-1 [LEAK VALUE]

Enter the calibration leak value used for external calibration leak. Select the unit. Select the unit used for external calibration leak.

- 2)-2 [VALVE CONTROL]

Set the control method of external calibration leak. Sensitivity calibration operates **AUTO** when automatic mode is set at the time of startup. When Manual mode is set, you will be required to operate open/close action of calibration leak in accordance screen guidance.

- 3) [EXTERNAL CALIBRATION LEAK (FOR SNIFFER METHOD)]

- 3)-1 [LEAK VALUE]

Enter channel type calibration leak value used for Sniffer method. Select the unit. Select the unit used for the channel type calibration leak.

- 4) [STANDARD GAS (FOR SNIFFER METHOD)]

- 4)-1 [CONCENTRATION]

Enter concentration of the gas to be the criteria.

5-5 List of Settings for Shipment from Manufacturer

Each setting values at the time of shipment from manufacturer is as listed below. Make necessary changes if required.

Setting Item	Description	Shipment Default Setting	
GENERAL	GAS	HELIUM, HYDROGEN	
	TEST MODE		AUTO MODE, ULTRA FLOW FIX, FINE FLOW FIX, GROSS FLOW FIX, SNIFFER (FLOW RATE), SNIFFER (CONCENTRATION)
		CYCLE TEST	ON, OFF
		ROUGHING TIMER	CONSTANT PRESSURE, 010.0sec
		BACKGROUND TIMER	BELOW SP.2, 010.0sec, SKIP
		TEST TIMER	TEST END AT NG, 010.0sec
		He SPRAY TIMER	=TEST TIME, 010.0sec
	AUTO ZERO		1SHOT, ALTERNATE, INVALID
	Vent	CONTROL	ATUO, MANUAL, INVALID
		VENTING TIMER	NORMALLY OPEN, 010sec
	Calibration: Selection except SNIFFER (concentration) Calibration: When SNIFFER (concentration) selected	START-UP	INT. CAL. LEAK, EXT. CAL. LEAK
			ATM, STD. GAS
			ON, OFF
		ION VOLT ADJ. CHECK	AT START-UP ONLY, AT EVERY CAL. NOT CHECK, ±10.0%
		TOLERANCE	±10.0%
		RETRY	03 TIMES
	OPERATION LOCK		VALID, INVALID
	PASSWORD		0000
	INDICATI ON/MESS AGE	TEST SCREEN	GRAPH, METER, VAC. DIAGRAM, VALUE
		UNIT	LEAK RATE
PRESSURE			Pa, mbar, atm, Torr
LEAK RATE COEFFICIENT			x01.00
LEAK RATE FILTER			FAST, NORMAL, SLOW
MESSAGE		NOTICE	VALID, INVALID
	MAINTENANCE	VALID, INVALID	

Setting Item	Description	Shipment Default Setting	
SERIAL COMM./EXT.I/O	CONTROL	TABLET, EXT.I/O, SERIAL COMM.	
	COMPATIBILITY	NONE, MODEL 710/700, MODEL 300, MODEL ZERO	
	SERIAL COMM.	RS232C, RS485	
	RS232C	RS232C Baud Rate	9600, 19200, 38400
	RS485	RS485 Baud Rate	9600, 19200, 38400
		CHECK SUM	ON, OFF
		ADDRESS	01
	PRINTER		ON, OFF
	REC. OUT VOLTAGE		LINEAR, LOGARITHM
	SETPOINT	SP1	5.00×10^{-9}
		BUZZER	ON, OFF
SP2		5.00×10^{-8}	
SP3		5.00×10^{-7}	
CALIBRATION/STANDARD	INTERNAL CALIBRATION LEAK	LEAK VALUE	2.0×10^{-8} Depends on the equipment
		TEMP./DECAY COMPENSATION	VALID, INVALID
		CALIBRATED DATE	Depends on the equipment
	EXTERNAL CALIBRATION LEAK (FOR VACUUM METHOD)	LEAK VALUE	$2.00 \times 10^{+0}$
		UNIT	$\text{Pa} \cdot \text{m}^3/\text{s}$, $\text{mbar} \cdot \text{l/s}$, $\text{atm} \cdot \text{cc/s}$, $\text{Torr} \cdot \text{l/s}$, lusec , Mol/s , sccm , oz/a , g/a
		VALVE CONTROL	AUTO, MANUAL
	EXTERNAL CALIBRATION LEAK (FOR SNIFFER METHOD)	LEAK VALUE	$2.00 \times 10^{+0}$
		UNIT	$\text{Pa} \cdot \text{m}^3/\text{s}$, $\text{mbar} \cdot \text{l/s}$, $\text{atm} \cdot \text{cc/s}$, $\text{Torr} \cdot \text{l/s}$, lusec , Mol/s , sccm , oz/a , g/a
	STANDARD GAS (FOR SNIFFER METHOD)	CONCENTRATION	$5.00 \times 10^{+0}$

6. INFORMATION

6-1 SERVICE

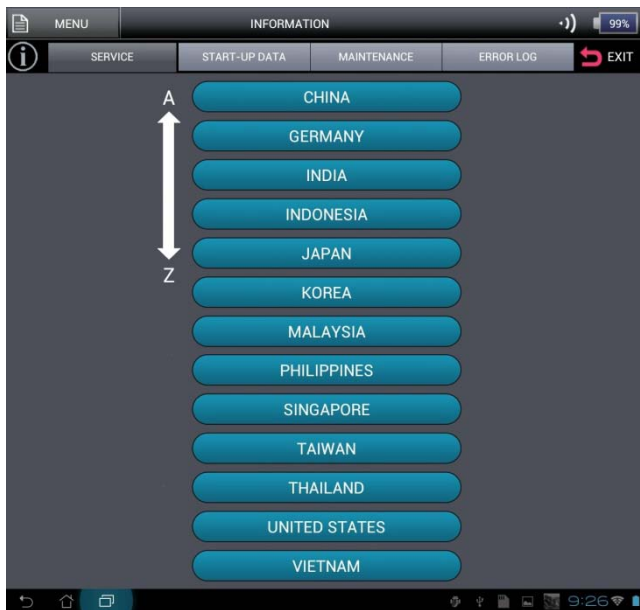

Displays servicing bases of ULVAC group.
Displays the telephone numbers of servicing bases when a country is selected.

6-2 START-UP DATA



Allows to check sensitivity data, etc. at startup.

6-3 MAINTENANCE (901W1/904W2)

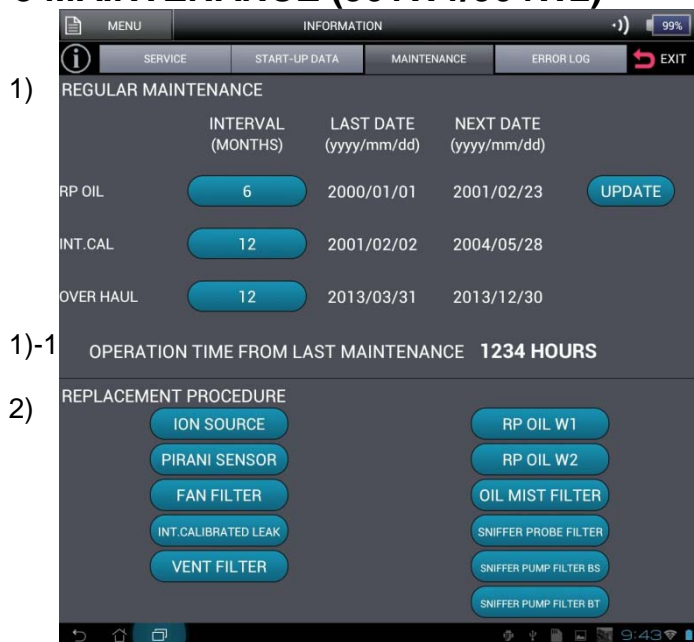

Allows you to check on information of the items requiring periodical maintenance. Verification of maintenance record by the manufacturer and recording of the maintenance date are made possible. Available for preventive maintenance.

1) REGULAR MAINTENANCE

Cycle of each periodical maintenance can be entered by the user.

When the cycle of next set maintenance date exceeds, the top screen "maintenance alarm" lights.

When this icon is selected, this screen can be reached from any other screen.

As for RP Oil, pressing **UPDATE** displays verification screen, where **YES** can be selected if the oil has been replaced. Then the last date of replacement will be updated. The date will not be updated when **X** is pressed.

1)-1 OPERATION TIME FROM LAST MAINTENANCE

Cumulative time from the last O/H is recorded. This can be used for controlling the operating time.

2) REPLACEMENT PROCEDURE

Shows replacement procedure for each maintenance items.

6-4 MAINTENANCE (901D2/904D3)

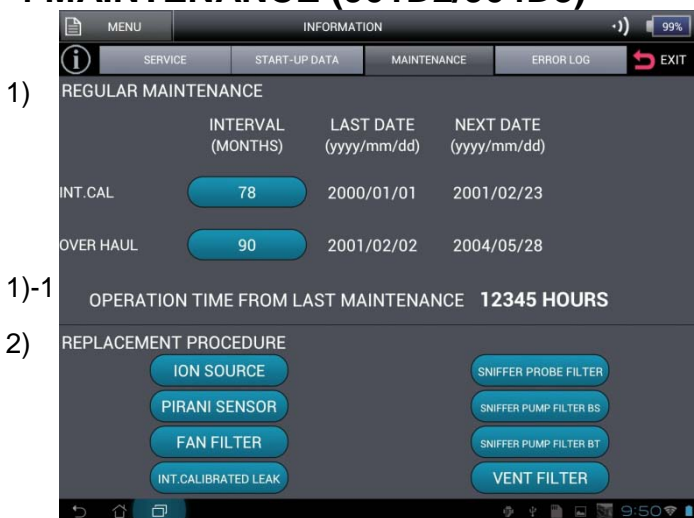

Allows you to check necessary items that require periodical maintenance. Enables you to check manufacturer's maintenance record and record the date of the maintenance user has conducted. Available for preventive maintenance.

1) REGULAR MAINTENANCE

Available for the user to enter the cycle of each periodical maintenance.

When the cycle of next set maintenance date exceeds, the top screen "maintenance alarm" lights.

When this icon is selected, this screen can be reached from any other screen.

1)-1 OPERATION TIME FROM LAST MAINTENANCE

Cumulative time from the last O/H is recorded. This can be used for controlling the operating time.

2) REPLACEMENT PROCEDURE

Shows replacement procedure for each maintenance items.

6-5 ERROR LOG





DATE	TIME	ERROR CODE	PROBLEM
2014/09/10	15:04	W01u	TEMPERATURE WARNING

Displays the error code generated. The maximum number of data stored is 100 data. In case 100 data exceeds, data is deleted from the oldest data. See Section 9-3 for details.

7. Startup

The startup method depends on vacuum method or Sniffer method.

7-1 Startup of Vacuum Method

 CAUTION	Use of Blank Flange Install blank flange to the test port when using under vacuum method. Starting the equipment by connecting pipings and testing unit may result in abnormal operation
 CAUTION	Startup/Sensitivity Calibration (Vacuum Method) When executing sensitivity calibration, install blank flange to the test port first. Risk of adverse impact on measurement due to incorrect calibration of sensitivity if the sensitivity calibration is executed with large capacity pipings installed.
 CAUTION	Startup Without Calibration The startup without calibration will apply the latest sensitivity data used, regardless of the current state of the equipment. It may have a large adverse impact to the measurement value depending on the difference in the state and conditions of the equipment. For the benefit of measurement reliability startup with calibration is recommended.

Sliding the start button  on the Initial Screen, changes to startup screen. It takes approximately 2 minutes without calibration and 5 minutes with calibration to complete the startup. Except when **EXT. CAL. LEAK** is selected for [GENERAL] – [CALIBRATION] – [START-UP] (Section 5-1_7), and **MANUAL** is selected for [CALIBRATION STANDARD] – [EXTERNAL CALIBRATION LEAK (FOR VACUUM METHOD)] – [VALVE CONTROL (Section 5-4_2)-2], the calibration leak valve connected to external area must be opened by the user before beginning the startup process. For the sensitivity calibration while startup, user will be required to operate button and close the calibration leak according to message will be needed.

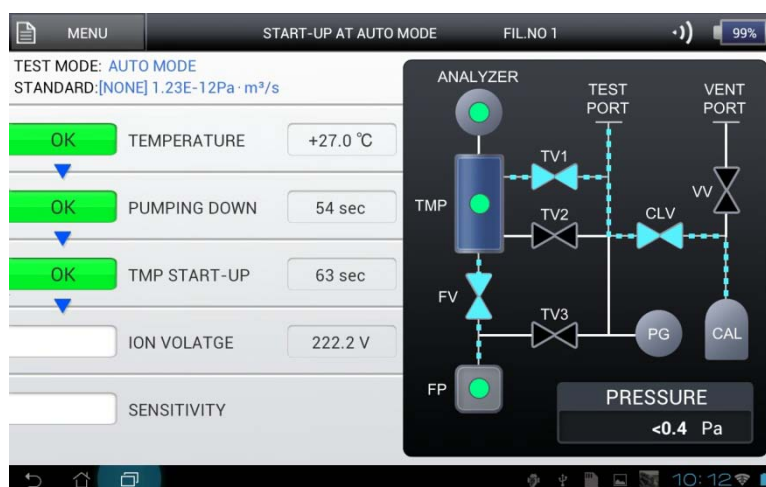

<Symbols for Exhaust System Diagrams>

No.	Display	Description
1	FIL.NO*	Indicates the filament No. currently illuminated.
2	ANALYZER	Analyzing tube. Illuminates up green when filament is illuminated.
3	TMP	Turbomolecular pump. Flashes yellow during startup. Also indicates rotation numbers by bar graph. When the pump reaches steady rotation, illuminates green.
4	FV	Fore valve which illuminates blue when the valve is opened.
5	FP	When fore pump activates, flashes yellow. When roughing verification is completed, illuminates green.
6	TV1,TV2,TV3	Each indicates test valve of 1, 2, 3. Illuminates blue with the valve opened.
7	TEST PORT	Test port.

No.	Display	Description
8	CLV	Valve for open/close of calibration leak. Illuminates blue with the valve opened.
9	PG	Indicates Pirani gauge head.
10	VV	Valve to inject atmosphere to the test port. Illuminates blue with the valve opened.
11	CAL	Indicates built-in calibration leak.
12	PRESSURE	Indicates the pressure of test port measured by PG.
13	VENT PORT	Port to inject atmosphere to the test port.

<Items to check for startup >

1) [TEMPERATURE]

Measures ambient temperature. Acceptable within the range of 10 to 45°C

2) [PUMPING DOWN]

Executes roughing process from fore line to test port. Acceptable if it reached to 100Pa within 180 seconds.

3) [TMP START-UP]

Acceptable if Steady rotation of TMP is within 240 second.

4) [ION VOLTAGE]

After verifying the startup of TMP, illuminates filament of ion source. Verifies proper emission current and adjusts accelerated speed after illuminating the filament. Acceptable if the accelerated voltage falls within the range of 215 to 250 V. If **[OFF]** is selected in setting mode during [GENERAL] – [CALIBRATION] – [START-UP] (Section 5-1_7)), the accelerated speed will not be adjusted but switches to the test screen.

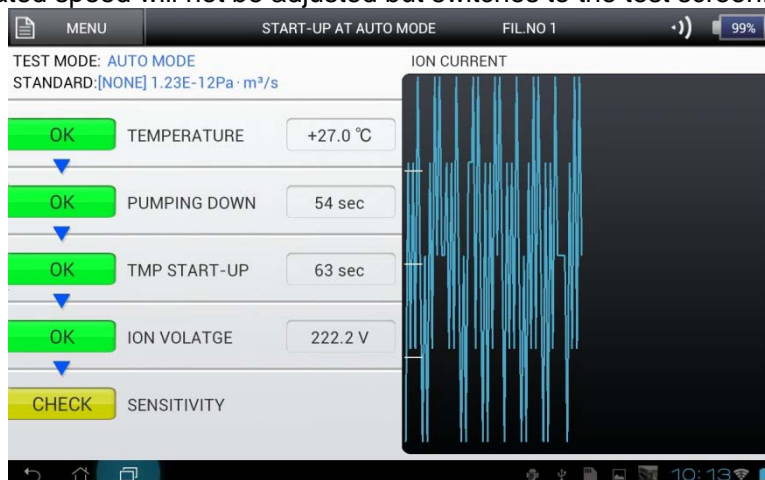

5) [SENSITIVITY]

SENSITIVITY CALIBRATION is executed under selected test mode to verify that the sensitivity is within the suitable range.

When **[EXT. CAL. LEAK]** is selected for [GENERAL] – [CALIBRATION] – [START-UP] (Section 5-1_7)), and **[MANUAL]** is selected for [CALIBRATION STANDARD] – [EXTERNAL CALIBRATION LEAK (FOR VACUUM METHOD)] – [VALVE CONTROL (Section 5-4_2)-2], the following actions by the user will be required.





- Press **[OK]** after verifying that the graph is stabilized.
- Close the valve of external calibration leak connected.
- Press **[OK]** after re-verifying that the graph is stabilized.

Operate according to the message shown on the upper screen within the dotted frame. After that, it will complete the startup automatically.

When all the startup items are completed, it switches to the test screen.

Startup data can be checked with [MENU]-[INFORMATION]-[START-UP DATA]

7-2 Startup of Sniffer Method

 CAUTION	Sensitivity Calibration (Sniffer Method) Sniffer unit must be connected to test port without fail when executing Sensitivity Calibration. If used without connecting to the Sniffer unit, correct sensitivity value may not be calibrated and may cause adverse effect to the measurement value.
 CAUTION	Prohibition of Intake Do no intake water, water vapor, oil mist and powers using Sniffer probe. Risk of malfunction and damage of the equipment.
 CAUTION	Channel Calibration Leak After vacuum exhausting of the interior of channel calibration leak, displacement of gas by pressurizing He is recommended before operating. Attention must be paid when pressurizing He from atmospheric pressure for direct connections to He cylinders because it may take 10–30 minutes to stabilize the input. If standing time for stabilization is insufficient, calibration leak output may not reach the calibration value or cause instability of output.
 CAUTION	Startup Without Calibration Startup without calibration will apply the latest sensitivity data used, regardless of the current state of the equipment. It may have a large adverse impact to the measurement value depending on the difference in the state and conditions of the equipment. For the benefit of measurement reliability startup with calibration is recommended.

The startup by Sniffer method can be selected from 2 types of test modes; **[SNIFFER (FLOW RATE)]** and **[SNIFFER (CONCETRATION)]**. Sensitivity calibration differ according to the above test modes chosen.

When **[SNIFFER (FLOW RATE)]** is set: Either built-in calibration leak or external calibration leak (channel calibration leak) prepared separately by the user is selected as a criteria of sensitivity calibration

When **[SNIFFER (CONCETRATION)]** is set: Either atmosphere (5ppm He gas present in the atmosphere) or standard gas prepared separately by the user is selected for the gas used as a criteria of sensitivity calibration.

These settings are executed in advance by the setting items; **[GENERAL] – [CALIBRATION] – [START-UP]** (Section 5-1 7)).

7-2-1 **[SNIFFER (FLOW RATE)]**

- 1) Install Sniffer Unit to the Test Port.
- 2) Prepare Channel Calibration Leak
 After vacuum exhausting the interior of channel calibration leak, displacement of gas by pressurizing He is recommended before operating. When pressurizing He from atmospheric pressure, it may take 10–30 minutes to stabilize the He leak. If standing time for stabilization is insufficient, calibration leak output may not reach the calibration value or cause instability of output.
- 3) Calibration Leak Value Setting before Startup
 After selecting **[SNIFFER (FLOW RATE)]**, enter Channel Leak Value and Calibration unit under **[CALIBRATION STANDARD] – [EXTERNAL CALIBRATION LEAK (FOR SNIFFER METHOD)]**.
- 4) Starting Startup
 Sliding the Start button  of the initial screen, switches to Startup screen and begins self checking function of the equipment.
 1) **[TEMPERATURE]** to 4) **[ION VOLTAGE]** consist of the same startup details as Vacuum method.

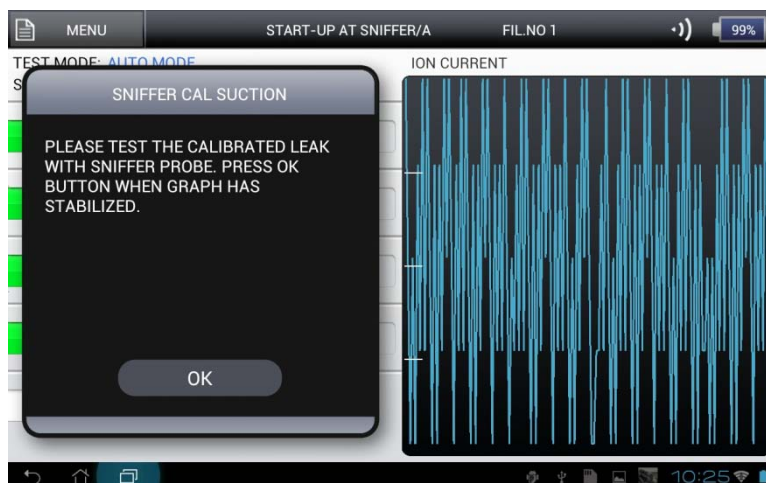

5) [SENSITIVITY]

5) -1 Calibration Leak setting: Set at Internal Calibration Leak (Section 5-1_7))

Built-in Calibration Leak is used for startup of the equipment's Sensitivity Calibration. After completion of the startup, it switches to test screen automatically.

5) -2 Calibration Leak setting: Set at External Calibration Leak (Section 5-1_7))

External Calibration Leak is used for the equipment's Sensitivity Calibration.

- "SNIFFER CAL SUCTION" will be indicated in the pop up, where user is required to intake calibrationleak according indication.
- When output is stabilized on the graph, press **OK** button. Sensitivity calibration will terminate.

After completion of the startup, it switches to test screen automatically.

7-2-2 **SNIFFER (CONCENTRATION)**

- 1) Install Sniffer Unit to the Test Port.
- 2) Prepare Standard Gas

Well-known gas concentration is used for concentration calibration. The user is required to prepare sufficient amount of gas in the atmosphere for intake which takes about several minutes. Plastic bags and other soft and enclosed type container for enclosing the gas would maintain the atmospheric pressure. During the startup intake of gas concentration is executed.

Atmospheric calibration uses He which is approximately 5ppm present in atmospheric pressure. The concentration of He within the atmospheric pressure depends on the environment and neither its traceability is available. It is recommended to use as a simplified calibration method. Atmospheric calibration starts up while absorbing atmosphere from the tip of the probe.

- 3) Setting of Standard Gas Concentration before Starting Startup

After selecting **SNIFFER (CONCENTRATION)** in the Test mode selection (Section 5-1_2)), enter standard gas concentration under [CALIBRATION STANDARD] – [STANDARD GAS (FOR SNIFFER METHOD)] (Section 5-4_4)-1). The unit used is ppm only.

- 4) Starting Startup

Sliding the start button **▶** of the initial screen, switches to startup screen and begins self checking function of the equipment.

1) [TEMPERATURE] to 4) [ION VOLTAGE] consist of the same startup details as vacuum method.

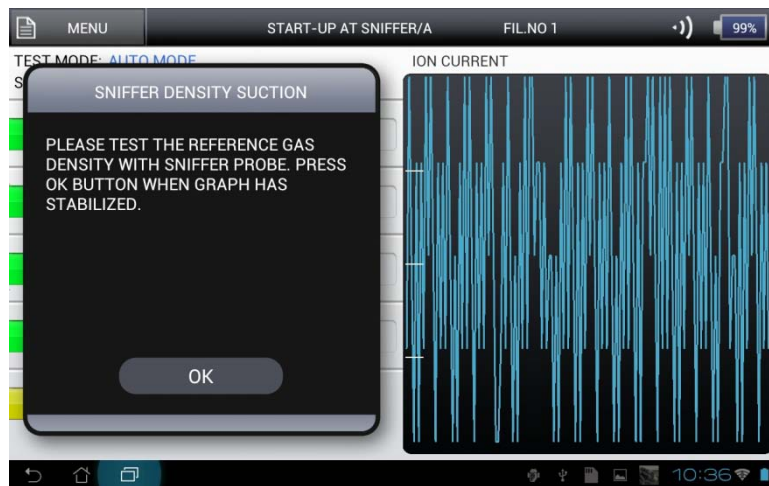

5) [SENSITIVITY]

5)-1 During Calibration Startup: Set at ATM (Section 5-1_7))

Atmosphere is used for startup of sensitivity calibration of the equipment. After completion of the startup, it switches to test screen automatically.

5)-2 During Calibration Startup: Set at STD. GAS (Section 5-1_7))

Standard gas concentration is used for sensitivity calibration of the equipment.

- "SNIFFER DENSITY SUCTION" will be indicated in the pop up, where user is required to intake Standard gas according to the indication.
- When output is stabilized on the graph, press **OK** button. Sensitivity calibration will terminate.

After completion of the startup, it switches to test screen automatically.

8. Testing
8-1 Test Screen
8-1-1 Graph

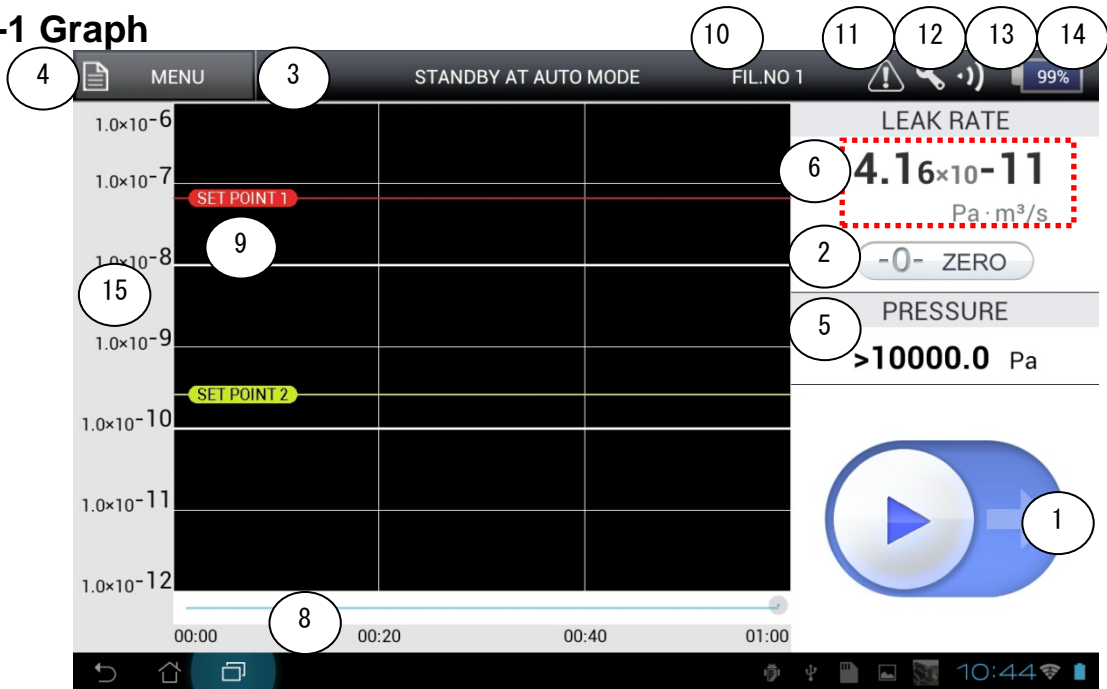

8-1-2 Meter

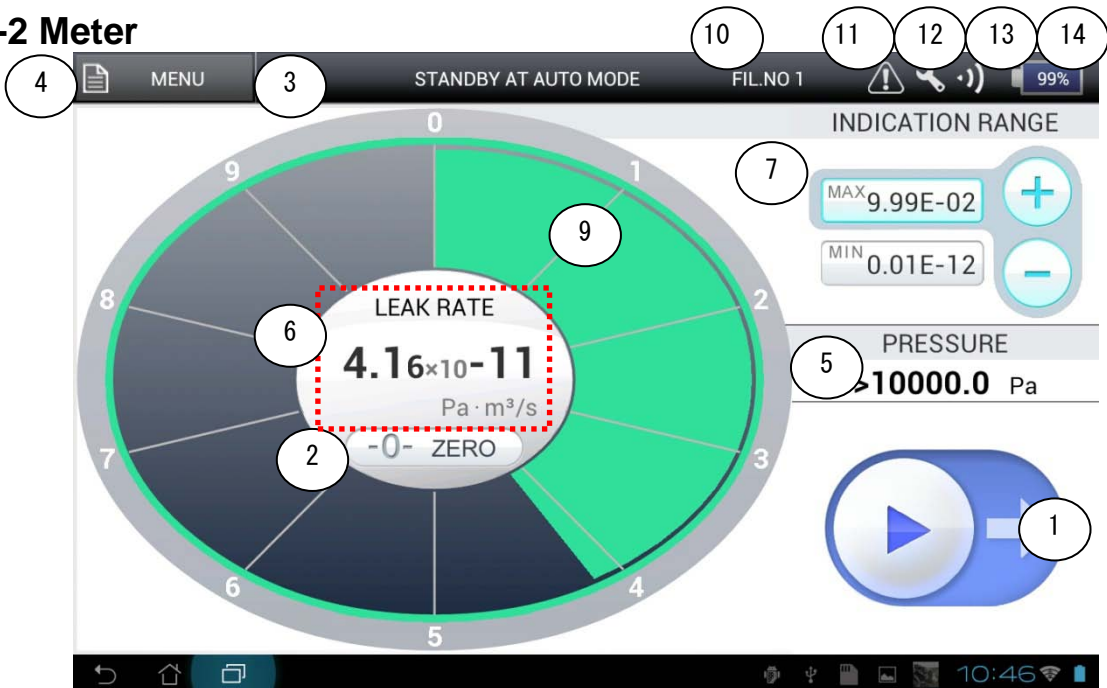

8-1-3 Vac. DIAGRAM

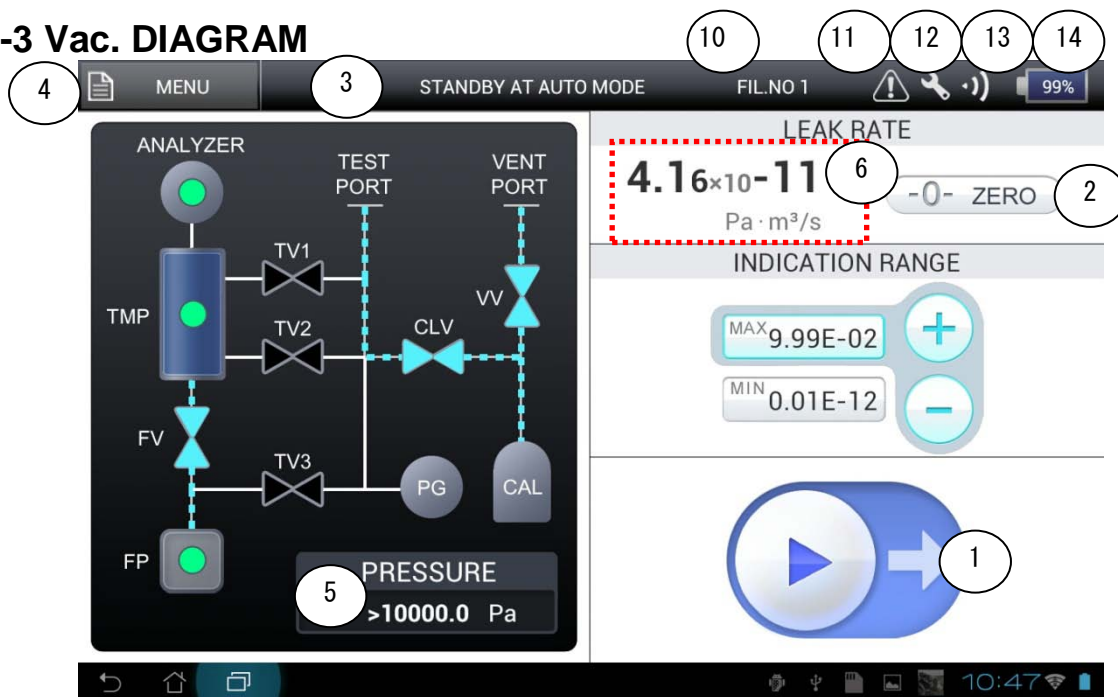

8-1-4 VALUE

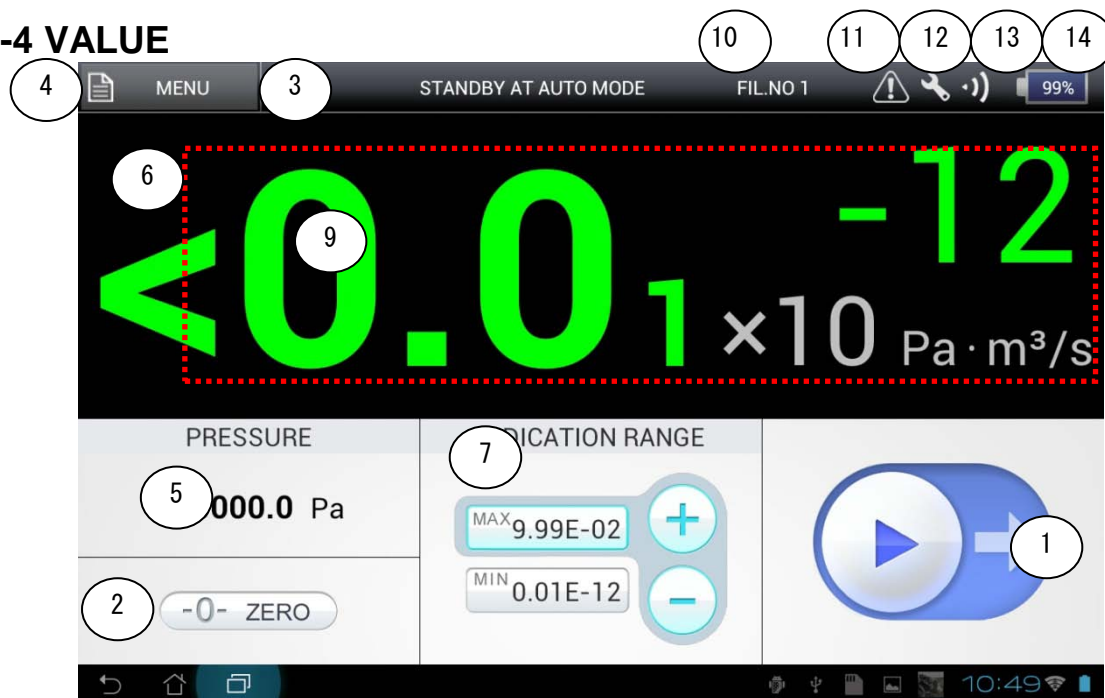

No.	Name	Function
1	Start/End/Vent Buttons for Testing	Slide when executing start/end/vent of the testing.
2	Auto Zero Button	Changes the indicator to zero during testing. Refer to description (Section 8-3) of setting screen for details.
3	Status Display	Real-time display of status.
4	MENU Button	Refer to (Section 3-3)
5	Test Port Pressure	Displays pressure of the test port. (<0.4 - > 10000Pa)
6	Leak Rate	Displays measurement value during testing and the value of previously completed test during stand-by mode. Measurement value is printed out (Section 11-3-1) when the red dotted portion of the frame is pressed during testing.

No.	Name	Function
7	Measurement Range	Sets measurement range width of leak rate. With this setting the voltage value (Section 11-2-2-4) of LOG recorder output is determined. When using the test screen as a graph, set the other test screen with the width of measurement range.
8	Measurement Time	When using graph display set the measurement period by touching measurement time area with 2 fingers and opening (pinch out) and closing (pinch in) the finger space. Pervious graphs can be checked if testing is completed.
9	SETPOINT	Displays SETPOINT 1, 2 Displays green if SETPOINT is not more than 1, 2. Displays red if SETPOINT is not less than 1. Display color changes to yellow if SETPOINT is not less than 2. If the setting of SETPOINT is $SP1 < SP2$, display will only be red SP1
10	Filament Number	FIL.NO1 is normally displayed. FIL.NO2 is displayed when the Filament 1 is not available.
11	Annotation of Error Marking	This marking will flash when a caution error is generated in the equipment and [INVALID] is selected under [INDICATION/MESSAGE] – [MESSAGE/NOTICE] (Section 5-2_6)). By pressing this marking, the screen changes to [INFORMATION] – [ERROR LOG] (Section 6-5) screen, where you will be advised to check the status of the equipment.
12	Maintenance Time Elapse marking	This marking will flash when maintenance cycle set in this equipment exceeds and [INVALID] is selected under [INDICATION/MESSAGE] – [MESSAGE/MAINTENANCE] (Section 5-2_7)). By pressing this marking, the screen changes to [INFORMATION] – [MAINTENANCE] (Section 6-3) screen, where you will be advised to check the status of the equipment.
13	Strength of Wireless LAN	Strength is displayed by wireless LAN communication between the equipment and tablet.
14	Battery Level	Displays the amount of battery remained in the tablet.
15	Graph Display	Displaying width can be set by touching display range part with 2 fingers and opening (pinch out) and closing (pinch in) finger space. Optionally set the width.

8-2 Test Mode



CAUTION

Weight on Test Port

When connecting pipe fittings to the test port, do not place weights over 50N. Risk of damaging the equipment.

Selected (Section 5-1_2)) from **AUTO MODE**, **ULTRA FLOW**, **FINE FLOW**, **GROSS FLOW**, **SNIFFER (FLOW RATE)**, **SNIFFER (CONCENTRATION)**. Each flow has the following features.





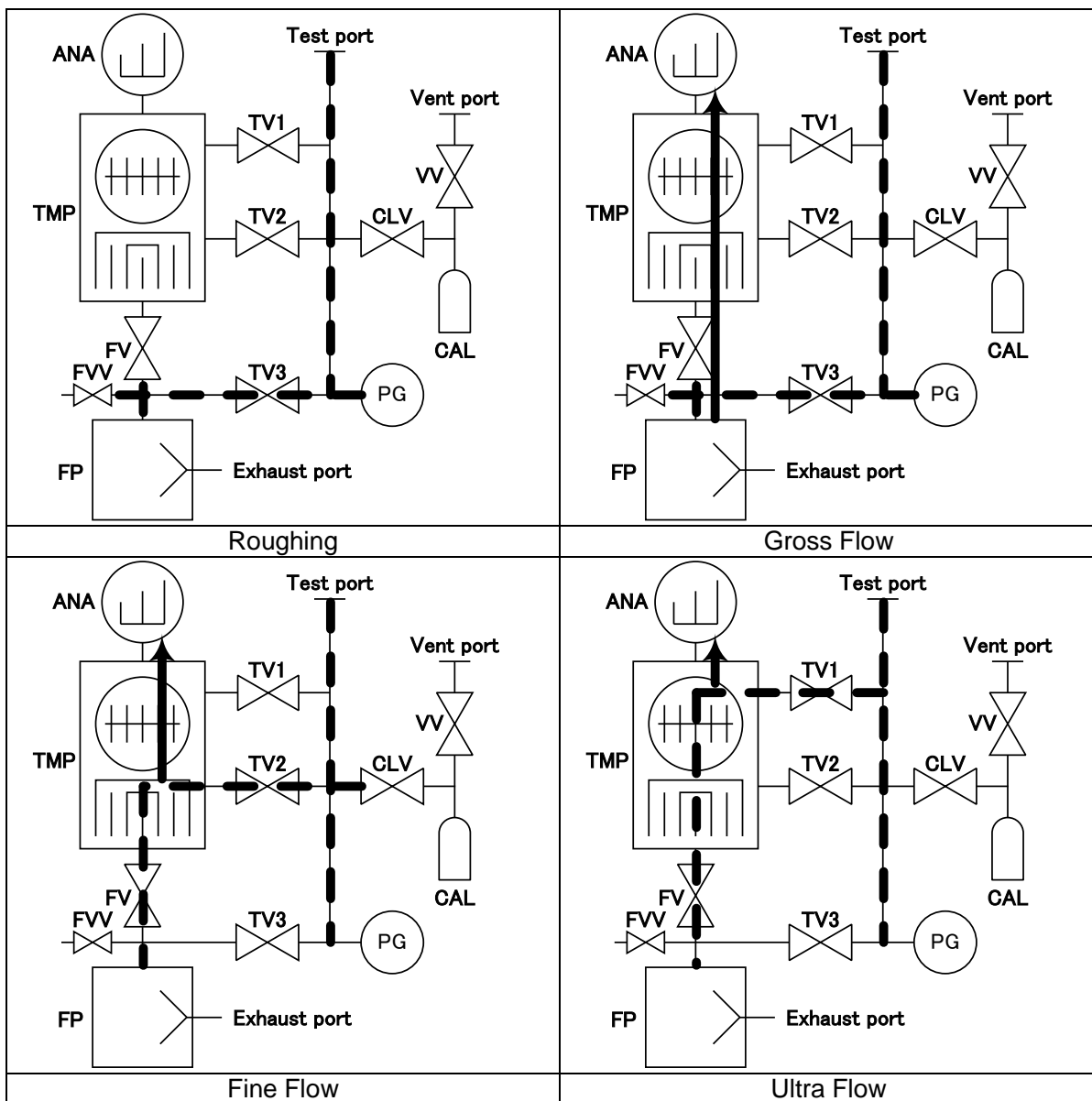

Test Flow	Test port Pressure Range			
	Pa	mbar	Torr	atm
Ultra Flow	< 2	< 0.02	< 0.015	< 0.00002
Fine Flow	< 100	< 1	< 0.75	< 0.001
Gross Flow	< 1200	< 10	< 7.5	< 0.01
Auto Flow	Gross, Fine and Ultra flows are automatically switched in accordance with pressure and leak rate			
Sniffer Flow	Atmospheric pressure	Atmospheric pressure	Atmospheric pressure	Atmospheric pressure

- * When measured gas is set at **H2** and the test mode is selected at **SNIFFER (FLOW RATE)** or **SNIFFER (CONCENTRATE)**, fine flow port will be selected automatically.
- * When Auto mode is selected, automatically switches the above flow according to test port pressure and measurement leak rate.
- * It is the capacity set by readings of built-in Pirani gauge head and may differ from the actual subject pressure of measurement.

Test Mode	Pa·m3/s	mbar·L/s Torr·L/s atm·cc/s	lusec	sccm	Mol/s
He Ultra Flow	0.01×10^{-12} ~ 10^{-06}	0.01×10^{-11} ~ 10^{-05}	0.01×10^{-08} ~ 10^{-02}	0.01×10^{-10} ~ 10^{-04}	0.01×10^{-16} ~ 10^{-10}
He Fine Flow	0.01×10^{-10} ~ 10^{-05}	0.01×10^{-09} ~ 10^{-04}	0.01×10^{-06} ~ 10^{-01}	0.01×10^{-08} ~ 10^{-03}	0.01×10^{-14} ~ 10^{-09}
He Gross Flow	0.01×10^{-08} ~ 10^{-03}	0.01×10^{-07} ~ 10^{-02}	0.01×10^{-04} ~ 10^{+01}	0.01×10^{-06} ~ 10^{-01}	0.01×10^{-12} ~ 10^{-07}
He Auto Mode	0.01×10^{-12} ~ 10^{-03}	0.01×10^{-11} ~ 10^{-02}	0.01×10^{-08} ~ 10^{+01}	0.01×10^{-10} ~ 10^{-01}	0.01×10^{-16} ~ 10^{-07}
H2 Fine Flow	0.01×10^{-08} ~ 10^{-05}	0.01×10^{-07} ~ 10^{-04}	0.01×10^{-04} ~ 10^{-01}	0.01×10^{-06} ~ 10^{-03}	0.01×10^{-12} ~ 10^{-09}
He Sniffer Flow (with AS Unit)	0.01×10^{-08} ~ 10^{-05}	0.01×10^{-07} ~ 10^{-04}	0.01×10^{-04} ~ 10^{-01}	0.01×10^{-06} ~ 10^{-03}	0.01×10^{-12} ~ 10^{-09}
He Sniffer Flow (with B* Unit)	0.01×10^{-07} ~ 10^{-03}	0.01×10^{-06} ~ 10^{-02}	0.01×10^{-03} ~ 10^{+01}	0.01×10^{-05} ~ 10^{-01}	0.01×10^{-11} ~ 10^{-07}

Test Mode	Oz/a	g/a	%xR	Amp.	ppm
He Ultra Flow	0.01×10^{-09} $\sim 10^{-04}$	0.01×10^{-08} $\sim 10^{-03}$	$0.01 \times 10^{+00}$ \sim $9.99 \times 10^{+07}$	0.01×10^{-16} \sim 9.99×10^{-10}	X
He Fine Flow	0.01×10^{-07} $\sim 10^{-02}$	0.01×10^{-06} $\sim 10^{-01}$			
He Gross Flow	0.01×10^{-05} $\sim 10^{+00}$	0.01×10^{-04} $\sim 10^{+01}$			
He Auto Flow	0.01×10^{-09} $\sim 10^{+00}$	0.01×10^{-08} $\sim 10^{+01}$			
H2 Fine Flow	0.01×10^{-05} $\sim 10^{-02}$	0.01×10^{-04} $\sim 10^{-01}$			
He Sniffer Flow (with AS Unit)	0.01×10^{-05} $\sim 10^{-02}$	0.01×10^{-04} $\sim 10^{-01}$			$0.01 \times 10^{+00}$ $\sim 10^{+03}$
He Sniffer Flow (with B* Unit)	0.01×10^{-04} $\sim 10^{+00}$	0.01×10^{-03} $\sim 10^{+01}$			



- 1) **Gross Flow**
Sliding the Start test button  of the test screen opens TV3, executes roughing and changes to testing when the pressure of test port becomes 1200Pa or less. Due to low detection sensitivity, it is not suitable for high sensitivity test but is capable of testing under high pressure. After starting the test, if the pressure deviates from the test port pressure range, the testing automatically stops.
- 2) **Fine Flow**
Sliding the Start button  of the test screen opens TV3, executes roughing and changes to testing when the pressure of test port becomes 100Pa or less. It is suitable for leak testing for a testing unit of leak rate of 10^{-10} to 10^{-5} [Pa·m³/s]. After starting the test, if the pressure deviates from the test port pressure range, the testing automatically stops.
- 3) **Ultra Flow**
Sliding the Start test button  of the test screen opens TV3, executes roughing and changes to testing when the pressure of test port becomes 2Pa or less.
Testing with Ultra Flow mode fixed, enables faster testing than connecting to Ultra Flow mode under auto mode.
It is suitable for leak testing of testing unit with leak rate of 10^{-10} [Pa·m³/s] or less. After starting the test, if the pressure deviates from the test port pressure range, the testing automatically stops.
- 4) **Auto Mode**
Sliding the Start test button  of the test screen executes roughing with TV3 and automatically switches to Gross, Fine, and Ultra Flows according to test port pressures and executes measurement. It is a suitable flow when the testing unit's leak rate and attained pressure are unknown. After starting the test, if the pressure deviates from the Gross Leak test port pressure range, the testing automatically stops. When the test flow switches, the display is fixed for a few seconds, thus this flow is not suitable for judging measurement values by external control.
- 5) **Sniffer Method**
Sliding the Start test button  of the test screen executes roughing with TV3 and starts testing after a certain elapse time. Sliding the End test button  of the test screen terminates the testing.

8-2-1 Cycle Test

(1) Overview

A single test cycle (Roughing/B.G. Monitoring/He spray signal/HeV output/up to acceptance evaluation) can be performed automatically.

Cycle test can be set when Ultra Flow, Fine Flow or Gross Flow are selected in the test mode setting.

(2) Operation Overview

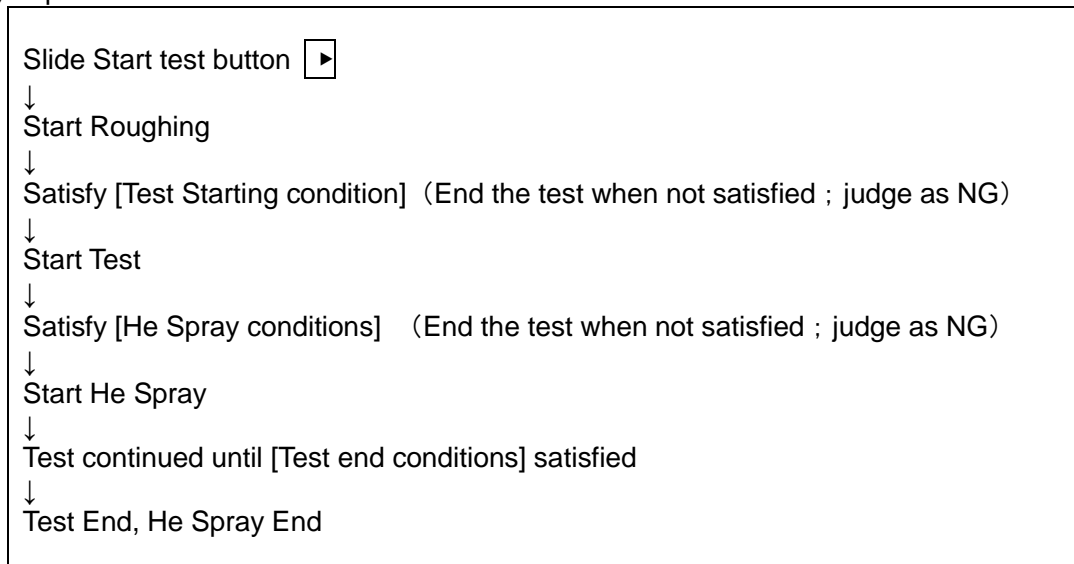

(3) Settings

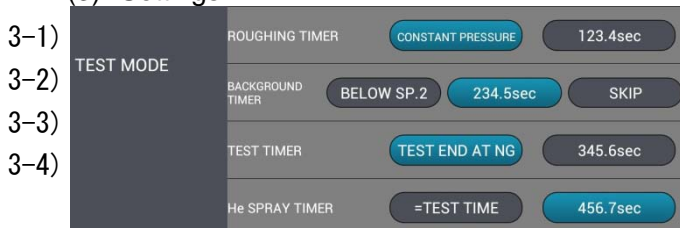

3-1) [Roughing Timer]

Specify roughing time.

Selecting starts the testing when acceptable pressure for testing is reached within the specified time.

Selecting does not start the testing unless the specified time elapses. If the acceptable pressure for testing is not reached within the specified time, the test is judged as NG and stops the testing.

3-2) [BACKGROUND Timer]

Selecting starts the testing when leak rate display becomes set point 2 or below even within the time specified.

When is selected, testing will not start unless the specified time elapses and yet leak rate display becomes set point 2 or below. If the leak rate display becomes set point 2 or above at the specified time elapsed, the test is judged as NG and stops the testing.

When is selected, regardless of leak rate display, as soon as the roughing completes, testing starts.

3-3) [Test Timer]

Selecting terminates the testing and judges as NG at the point when the leak rate display exceeds set point 1 even if it is within the specified time.

When is selected, after the specified time elapsed, set point 1 setting value and leak rate are compared on display and judged as OK/NG. After terminating the test the HELIOT will move to stand-by mode.

3-4) [He Spray Timer]

Set the output condition of He Spray signal/HeV output which is one of EXT.I/O (Section11-1).

Selecting **TEST TIME** executes He Spray signal/HeV output under the condition set with 3-3) TEST TIMER.

When **TIME** is selected, after starting output of He Spray signal/HeV output and after the specified time lapsed, output is turned OFF. If time setting is set to 0, He Spray signal/HeV output will not be executed.

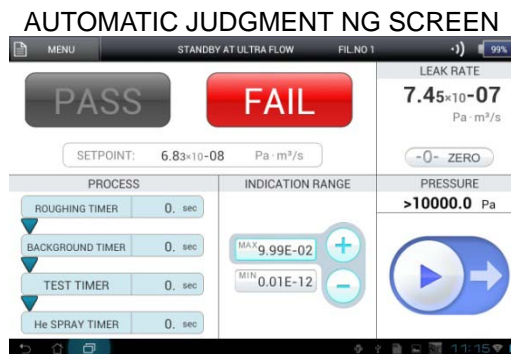
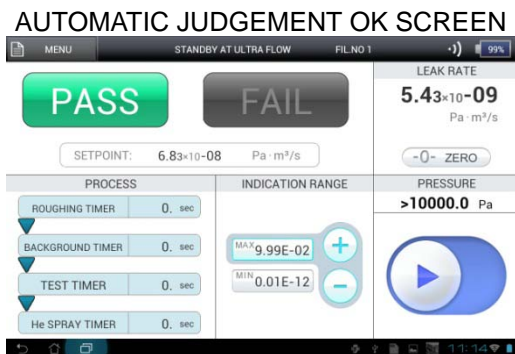

8-3 How to Use **-0-ZERO**

(1) Overview

Auto zero function resets the leak rate display during testing to zero (to the background value) by 3 seconds long press of **-0-ZERO** button on the screen. Also monitors the decrease of background and when the leak rate becomes zero or smaller resets zero automatically.

The B.G. value when Auto zero is turned ON.

- Ultra Flow : 0.0₁E-12 [Pa·m³/s]
- Fine Flow : 0.0₁E-10 [Pa·m³/s]
- Gross Flow : 0.0₁E-08 [Pa·m³/s]
- Sniffer (Flow Rate) : 0.0₁E-08 [Pa·m³/s] Unit (AS)
: 0.0₁E-07 [Pa·m³/s] Unit (BS/BT)
- Sniffer (Concentration) : 0.0₁E+00 [ppm] Unit (AS/BS/BT)

(2) Useful at a time like this

When executing a leak test, by resetting the measurement value (background) to zero before spraying He/H₂, the variation after spraying He/H₂, that is to say only the variation of measurement value by leakage can be displayed. It reduces the impact which the background gives to the measurement value.

(3) Caution

If ON is selected when the background is decreasing rapidly and/or is not stable, the monitoring of the background will not be fully traced, such as when immediately after the start of testing. Long press of 3 seconds for **-0-ZERO** button after checking the variation is the level that can be ignored within the measured time.

(4) Difference between **ALTERNATE** and **1SHOT**

There are 2 types of operational procedures for auto zero depending on the selection of **ALTERNATE** / **1SHOT** (Section 5-1_4)) in [AUTO ZERO SETTING]. **1SHOT** setting is recommended for general use. Their differences are described below.

- When **ALTERNATE** is selected
When **-0-ZERO** button is long pressed for 3 seconds, zero point is updated to display the leak as zero, which illuminates **-0-ZERO** blue. While the blue illuminates, leak rate display is monitored so that it will not become minus. If the leak rate displays minus, it automatically updates the zero point. When **-0-ZERO** button is long pressed again for 3 seconds, the blue lights out and switches to leak rate display (background variation immediately after startup) of zero point which was applied immediately after the startup setting. That is to say, each time the **-0-ZERO** is long pressed <Resetting of zero point> + <Monitoring of Minus> ← → <Background variation> is repeated. This function is effective for checking the amount of change took place in the background of the equipment from immediately after the startup. When the test is terminated, **-0-ZERO** will be released.
- When **1SHOT** is selected
-0-ZERO is always illuminated blue and the leak rate is monitored so that it does not display minus. When the leak rate displays minus, it automatically updates the zero point. Unlike when **ALTERNATE** is selected, the zero point is updated each time when **-0-ZERO** button is long pressed for 3 seconds. Thereby, display of background variation from startup is not possible but operation is relatively simple because it updates each time **-0-ZERO** is pressed.

The auto zero function is shown in the following graphs.

- When **ALTERNATE** is selected for auto zero setting.

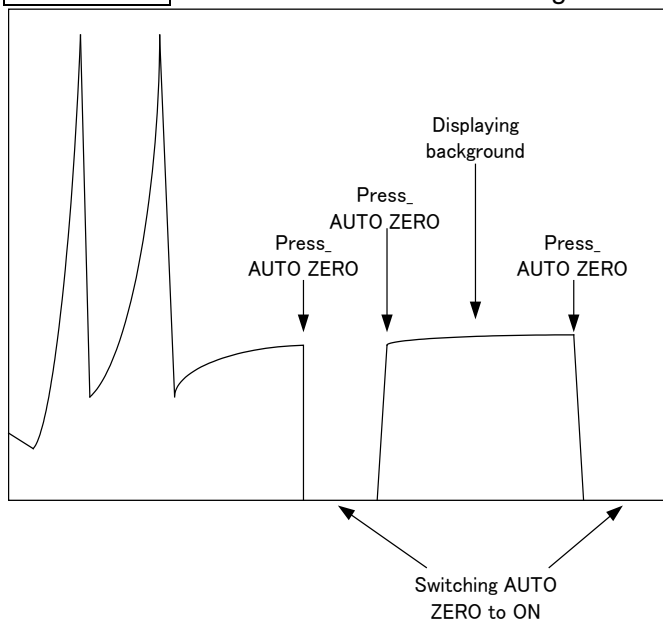

- When **1SHOT** is selected for auto zero setting.

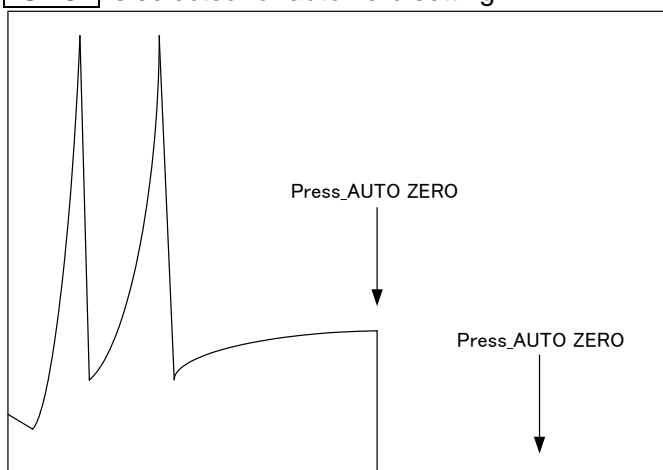

*Auto zero function does not distinguish between background and measurement value during testing. If resetting timing is not correct when pressing **-0-ZERO** for resetting zero point, risk of changing the value to zero for the value to be measured also. The operator is requested to fully understand the function before use.

*Auto zero will not function when display unit is set to **%xR, Amp.**

8-4 How to Use **CLEAN UP**

When large amount of He/H₂ is injected into the equipment during the test, this is a function to flush out He/H₂ from the interior of the equipment by injecting small amount of atmosphere. The steps below show the clean up operation.

- (1) Long press **MENU** button for 3 seconds. The menu window displays.
- (2) Press **CLEAN UP** button.
- (3) The message bar display on the test screen displays "CLEAN UP PROCESSING".
- (4) Executes approximately 5 seconds of clean up.
- (5) When clean up is completed, the display switches to test screen.

8-5 How to Use **CAL. START**



Function to execute Sensitivity Calibration from Test Standby mode. In order to maintain measurable condition with high accuracy, periodical (approx. once per every 1 - 4 hours) Sensitivity Calibration during continuous operation is recommended. Sensitivity Calibration is also effective for Startup in **OFF** mode through [GENERAL] – [CALIBRATION] – [START-UP] (Section 5-1_7)).

Before Sensitivity Calibration, install a blank flange to the test port for Vacuum Method and a Sniffer Unit for Sniffer method.

- (1) Long press **MENU** button for 3 seconds. The menu window displays.
- (2) Press **CAL. START** button.
- (3) Switches from Test Screen to Sensitivity Calibration Screen and executes Sensitivity Calibration.
- (4) When Sensitivity Calibration is completed, the display switches to test screen.

8-6 How to Use **CAL.CHECK**

Function to execute measurement of calibration leak from Test Standby. By measuring leak rate of calibration leak known, it is possible to check if suitable measurement value is attained.

- (1) Long press **MENU** button for 3 seconds. The menu window displays.
- (2) Press **CAL. CHECK** button.
- (3) The message bar display on the test screen displays "CAL. LEAK VALUE CHECK WAITING".
- (4) To reset (normal measuring mode). long press **MENU** button again for 3 seconds followed by **CAL. CHECK**.
- (5) Sliding  Start Test button on the test screen, displays "ROUGHING AT CAL. CHECK" on the message bar of the test screen during roughing and in case of testing, the message bar on the test screen displays "CAL. LEAK VALUE CHECKING" and executes calibration measurement.
- (6) When terminating calibration leak check, slide the End Test  button (Section 8-7).

*Leak Rate of calibration leak changes according to elapsed time from the calibration date and ambient temperature. See instruction manual for details of calibration leak.

8-7 End of Testing

Sliding End Test button  of test screen terminates the test and ventitates (atmosphere release) to the test port

- **AUTO** : Vents after the end of the test.
- **MANUAL** : Vents when sliding the Vent button after the end of the testing.
- **INVALID** : No vent is executed.

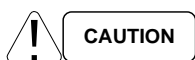

Atmosphere Release of Test Port

Do not release atmosphere of Test port by removing blank flanges, testing units or Sniffer units installed in the test port, or release atmosphere except by tablet operation before ventilation. Risk of damaging the equipment.

*If you wish to maintain the testing unit and inside of the piping in vacuum without releasing atmosphere after testing, installation of valves between the test port and testing unit is recommended.

8-8 Hydrogen Measurement



H₂ Measurements are greatly affected the condition of the equipment (background) when compared to He measurement. Measurement values in particular tend to be unstable immediately after startup completes. When measuring below E-7Pa·m³/s level, warm up of over 1 hour after completion of startup followed by sensitivity calibration is recommended before use.

**CAUTION**

Handling of Hydrogen Gas

There is a danger of explosion when hydrogen is mixed with atmosphere of 4% or more. Make sure to check the safety of the hydrogen gas or hydrogen mixture gas with MSDS before handling without fail.

9. Error Modes

 <div style="border: 1px solid black; border-radius: 5px; padding: 2px; display: inline-block;">CAUTION</div>	<p>Errors In the event of an error, release the error mode after checking the state of error described in the error message. See the troubleshooting section and service/repair as necessary.</p>
 <div style="border: 1px solid black; border-radius: 5px; padding: 2px; display: inline-block;">CAUTION</div>	<p>Release of Error Mode In the event of an error, release the error mode after checking the state of error described in the error message.</p>

Displays the detail of error in case of any abnormalities occurred with the equipment. Errors are classified into 2 types as “Warning Error” and “Caution Error”. After displaying the message of abnormal condition, “Warning Error” stops the operation and “Caution Error” recovers the operation by pressing .

“Caution Error” will not be displayed when **INVALID** is set for [INDICATION/MESSAGE] – [MESSAGE] – [NOTES] (Section 5-2_6). When error message is shown, immediate servicing or repair of equipment is needed.

9-1 Warning Errors

Warning error occurs in case of problems at startup or failure in testing. If an error occurs at startup, it stops immediately. If the warning error occurs during testing, the test stops and the test port releases the atmosphere. Then enters stop mode to stop the equipment.

- 1) Error occurs during operation. It stops operation in parallel with the start of warning error. Then the following warning screen displays.

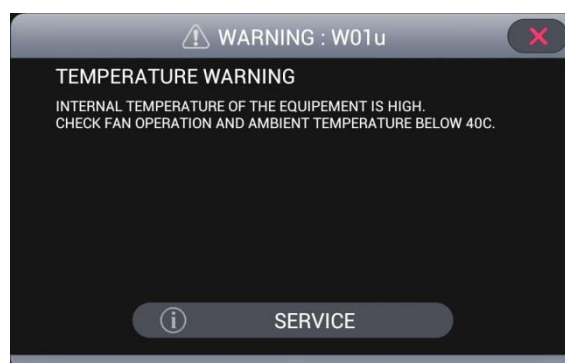

- 2) The error screen displays its detail and what may be considered as the cause. Read the detail of the error carefully and inspect it accordingly. By pressing **SERVICE**, a list of Service Desks will be displayed. Changes to initial mode when is pressed.
- 3) If the condition does not ameliorate after inspection, please contact your nearest Service Desk.

9-2 Caution Errors

Caution errors do not have serious impact to startup or testing of the equipment. However, it may have serious impact to the equipment in the future

- 1) Error occurs during operation. During startup of the equipment, errors do not display immediately. After completion of the startup, the following message displays. Also, as for the errors occurred during testing, error is displayed immediately.
The message shows the details of what may be considered as the cause. Except when [INDICATION/MESSAGE] – [MESSAGE] – [NOTICE] (Section 5-2_6)) is set as [INVALID], the error screen will not be displayed.



- 2) Check the details of the error message and repair/service accordingly. Caution Error does not require immediate maintenance. However, in order for you to use the equipment in a safer environment, we recommend maintenance of the equipment.
- 3) By pressing [X], maintains the Test Mode Standby or Test state. Changes to maintenance screen by pressing [MAINTENANCE]. If the condition does not ameliorate after servicing, please contact your nearest Service Desk.

9-3 List of Error Messages

9-3-1 Warning Errors

Following is the list of all the error messages displayed in this equipment. Warning messages are shown with W OR C at the head of the numbers + state occurred and caution messages are shown with N at the head of the numbers + state occurred.

Key modes: A: Startup/sensitivity calibration, B: Standby, C: Testing

Error Code				Error Message/Abnormal Condition	Remarks
A	B	C			
W01	u	s	t	TEMPERATURE WARNING Temperature within the equipment rose to 55°C and over	1) Check the ambient temperature 2) Possibility of dirty air filter of air cooling fan
C02	u	s	t	PIRANI SENSOR BURN OUT Filament of Pirani vacuum gauge was disconnected.	1) Pirani gauge head may be disconnected. Replace the Pirani gauge head. 2) Is there any water vapor or oil mist being injected to the equipment? If any of the above are adhered to pollute the Pirani gauge head, the equipment will diagnose it as disconnection. Replacement of Pirani gauge head is necessary.
C03	u	s	t	FOREPUMP OVERLOAD Circuit protector for protecting Fore Pump operated because the temperature of the Fore Pump was detected as being too low.	1) Push back the circuit protector for Fore Pump on the connector panel. 2) Start after setting the ambient temperature to 10°C and over.
C04	u	s	t	FORE PUMP OVERLOAD Circuit protector for protecting Fore Pump operated.	1) Push back the circuit protector for Fore Pump on the power supply panel. 2) Check to see that the exhaust vent port is not obstructed.
C05	u	s	t	SNIFFER PUMP OVERLOAD Circuit protector for protecting Sniffer Pump operated.	1) Push back the circuit protector for Sniffer Pump on the connector panel.
W06	u	s	t	TMP OVERLOAD Error occurred in the Turbomolecular Pump.	1) Wasn't the pressure of test port increased suddenly during operation? Protective circuit causes the pump to stop when the pressure rises suddenly.

C10	u	—	—	<p>ROUGHING ERROR AT START-UP</p> <p>A state where Test Port is unable to vacuum pump at 100Pa or below (within 180 seconds) at Startup.</p>	<ol style="list-style-type: none"> 1) Connect the blank flange to the Test Port and execute Startup. 2) If the internal capacity of the sample is large, exhausting by single main equipment may not be possible. If error frequently occurs, install a separate exhaust system. 3) When using rotary pump, is the oil being replaced? Is maintenance of Fore Pump being executed? Check the maintenance period and if it is approaching, execute the maintenance.
C11	u	—	—	<p>TMP ROTATION ERROR</p> <p>A state where rotation number of Turbomolecular pump does not reach steady rotation (within 240 seconds) at Startup.</p>	<ol style="list-style-type: none"> 1) Is there been any case of subjecting the Turbomolecular pump to a frequent sudden rise in pressure? Rapid rise in pressure will cause malfunction of Turbomolecular pump. 2) Is the Wick holder being replaced periodically? Replacement of once in 2 years is required as a target.
C12	u	—	—	<p>DC-AMP ERROR</p> <p>Ion detection current value is detected at 1.00e-13[A] or over.</p>	<ol style="list-style-type: none"> 1) DC amp is damaged. Contact your nearest Service Desk.
W13	u	s	t	<p>EMISSION ERROR (LOW)</p> <p>If emission current is unable to obtain. (When filament of ion source is disconnected).</p>	<ol style="list-style-type: none"> 1) Is the connector of ion being securely connected? Restart by reconnecting the connector. 2) Replace ion source by referring to replacement method of ion source.
W14	u	s	t	<p>EMISSION ERROR (HIGH)</p> <p>When filament current is damaged</p>	<ol style="list-style-type: none"> 1) Control wiring board is damaged. Contact your nearest Service Desk.
C15	u	—	—	<p>CANNOT FIND He/H2 PEAK</p> <p>When He/H2 peak cannot be obtained by adjusting accelerated voltage.</p>	<ol style="list-style-type: none"> 1) A state where He/H2 peak cannot be detected during accelerated voltage adjustment. The calibration leak of [GENERAL] – [CALIBRATION] – [START-UP] is set with a internal calibration leak and verify the startup.
C16	u	—	—	<p>PEAK HEIGHT OVER RANGE</p> <p>When He/H2 peak voltage exceeded over during accelerated voltage adjustment.</p>	<ol style="list-style-type: none"> 1) At accelerated voltage adjustment, peak voltage is outside of the reference range. The calibration leak of [GENERAL] – [CALIBRATION] – [START-UP] is set with a internal calibration leak and verify the startup.
C17	u	—	—	<p>PEAK POSITION OVER RANGE</p> <p>When accelerated voltage is outside of proper voltage value.</p>	<ol style="list-style-type: none"> 1) Possibility of dirty analyzer tube. Early overhaul is recommended.
C18	u	s	t	<p>CIRCUIT PROTECTOR I/O TRIPPED</p> <p>When circuit protector of DC24 V which outputs from EXT.I/O operated.</p>	<ol style="list-style-type: none"> 1) EXT.I/O circuit protector located in the connector panel tripped. Verification is necessary. 2) Wiring and external system (sequencers) need to be checked.

W19	u	s	t	<p>CIRCUIT PROTECTOR FILAMENT TRIPPED</p> <p>When circuit protector for filament circuit power supply operated.</p>	<ol style="list-style-type: none"> 1) Circuit protector within the control wiring board tripped. Verification is necessary. 2) Check the cable for ion source and fixing for oil source.
C21	u	—	—	<p>SENSITIVITY DEFECT (VACUUM)</p> <p>When worse than resulting sensitivity range of the sensitivity calibration.</p>	<ol style="list-style-type: none"> 1) Is the maintenance for Fore Pump being executed? Check the maintenance time of the Fore Pump and if the maintenance time is approaching, an early overhaul is recommended. 2) Is the ion source clean? The ion source is a consumable. When you find the sensitivity is reducing, replacement is recommended.
C22	u	—	—	<p>SENSITIVITY TOO HIGH (VACUUM)</p> <p>When better than resulting sensitivity range of the sensitivity calibration.</p>	<ol style="list-style-type: none"> 1) Was the large amount of He being absorbed during the last measurement time? The concentration of He within the equipment is becoming high. Several operations of start/stop are needed. 2) Is the maintenance of Fore Pump being executed? Check the maintenance time of the Fore Pump and if the maintenance time is approaching, an early overhaul is recommended. 3) Is the ion source clean? The ion source is a consumable. When you find the sensitivity is reducing, replacement is recommended.
C23	u	—	—	<p>SENSITIVITY DEFECT (SNIFFER)</p> <p>When worse than resulting sensitivity range of the sensitivity calibration</p>	<ol style="list-style-type: none"> 1) Is the pressure of He cylinder at normal? Channel calibration leak is calibrated at 0.1MPa. Verification of supplied pressure is necessary. 2) Is the maintenance of Fore Pump being executed? Check the maintenance time of the Fore Pump and if the maintenance time is approaching, an early overhaul is recommended. 3) Is the ion source clean? The ion source is a consumable. When you find the sensitivity is reducing, replacement is recommended.

C24	u	—	—	<p>SENSITIVITY TOO HIGH (SNIFFER)</p> <p>When better than resulting sensitivity range of the sensitivity calibration</p>	<ol style="list-style-type: none"> 1) Is the pressure of He cylinder at normal? Channel calibration leak is calibrated at 0.1MPa. Verification of supplied pressure is necessary. 2) Is the maintenance of Fore Pump being executed? Check the maintenance time of the Fore Pump and if the maintenance time is approaching, an early overhaul is recommended. 3) Is the ion source clean? The ion source is a consumable. When you find the sensitivity is reducing, replacement is recommended.
C25	u	—	—	<p>SENSITIVITY DEFECT (SNIFFER)</p> <p>When worse than resulting sensitivity range of the sensitivity calibration</p>	<ol style="list-style-type: none"> 1) Is the maintenance of Fore Pump being executed? Check the maintenance time of the Fore Pump and if the maintenance time is approaching, an early overhaul is recommended. 2) Is the ion source clean? The ion source is a consumable. When you find the sensitivity is reducing, replacement is recommended.
C26	u	—	—	<p>SENSITIVITY TOO HIGH (SNIFFER)</p> <p>When better than resulting sensitivity range of the sensitivity calibration</p>	<ol style="list-style-type: none"> 1) Has He being used before startup of the equipment? The concentration of He within the environment is becoming high. Find a place where He concentration is stable and restart. 2) Is the maintenance of Fore Pump being executed? Check the maintenance time of the Fore Pump and if the maintenance time is approaching, an early overhaul is recommended. 3) Is the ion source clean? The ion source is a consumable. When you find the sensitivity is reducing, replacement is recommended.

9-3-2 Caution Errors

Key modes: A: Startup/sensitivity calibration, B: Standby, C: Testing

Error Code				Error Message/Abnormal Condition	Remarks
A	B	C			
N01	u	s	t	<p>TEMPERATURE WARNING</p> <p>When the temperature within the equipment rise to 45°C and over. When the filter is dirty</p>	<ol style="list-style-type: none"> 1) Check the ambient temperature 2) Air filter of air cooling fan may be dirty.
N10	u	—	—	<p>ROUGHING ERROR AT Re-CALIBRATION</p> <p>A state where Test Port is unable to vacuum pump at 100Pa or below at Roughing Sensitivity Re-calibration</p>	<ol style="list-style-type: none"> 1) Connect the blank flange to the Test Port and execute startup. 2) Has the maintenance of Fore Pump being executed? Check the maintenance time of the Fore Pump and if the maintenance time is approaching, an early overhaul is recommended. 3) If cycle test is selected, adjust the roughing time of the cycle to a proper value.
N11	u	—	—	<p>ROUGHING ERROR AT Re-CALIBRATION</p> <p>A state where Test Port is unable to vacuum pump at 100Pa or below at Roughing Sensitivity Re-calibration</p>	<ol style="list-style-type: none"> 1) Is the maintenance of Fore Pump being executed? Check the maintenance time of the Fore Pump and if the maintenance time is approaching, an early overhaul is recommended. 2) If cycle test is selected, adjust the roughing time of the cycle to a proper value.
N21	u	—	—	<p>SENSITIVITY FALL(VACUUM)</p> <p>When worse than resulting sensitivity range of the sensitivity calibration. Ultra Flow: 3.00×10^{-12} and over Fine Flow: 3.00×10^{-11} and over Gross Flow: 1.00×10^{-06} and over</p>	<ol style="list-style-type: none"> 1) Is the maintenance of Fore Pump being executed? Check the maintenance time of the Fore Pump and if the maintenance time is approaching, an early overhaul is recommended. 2) Is the ion source clean? The ion source is a consumable. When you find the sensitivity is reducing, replacement is recommended.

N22	u	—	—	<p>SENSITIVITY TOO HIGH (VACUUM)</p> <p>When better than resulting sensitivity range of the sensitivity calibration. Ultra Flow: 2.00×10^{-13} and below Fine Flow: 2.00×10^{-12} and below Gross Flow: 1.00×10^{-11} and below</p>	<ol style="list-style-type: none"> 1) Did the large amount of He being absorbed during the last measurement? The concentration of He within the equipment is rising. Several operations of start/stop are needed. 2) Is the maintenance of Fore Pump being executed? Check the maintenance time of the Fore Pump and if the maintenance time is approaching, an early overhaul is recommended. 3) Is the ion source clean? The ion source is a consumable. When you find the sensitivity is reducing, replacement is recommended.
N23	u	—	—	<p>SENSITIVITY FALL HIGH (SNIFFER)</p> <p>When worse than resulting sensitivity range of the sensitivity calibration. 1.00×10^{-08} and over</p>	<ol style="list-style-type: none"> 1) Is the pressure of He cylinder at normal? Channel calibration leak is calibrated at 0.1MPa. Verification of supplied pressure is necessary. 2) Is the maintenance of Fore Pump being executed? Check the maintenance time of the Fore Pump and if the maintenance time is approaching, an early overhaul is recommended. 3) Is the ion source clean? The ion source is a consumable. When you find the sensitivity is reducing, replacement is recommended.
N24	u	—	—	<p>SENSITIVITY TOO HIGH (SNIFFER)</p> <p>When better than resulting sensitivity range of the sensitivity calibration. 1.00×10^{-12} and below</p>	<ol style="list-style-type: none"> 1) Is the pressure of He cylinder at normal? Channel calibration leak is calibrated at 0.1MPa. Verification of supplied pressure is necessary 2) Has the maintenance of Fore Pump being executed? Check the maintenance time of the Fore Pump and if the maintenance time is approaching, an early overhaul is recommended. 3) Is the ion source clean? The ion source is a consumable. When you find the sensitivity is reducing, replacement is recommended.
N27	u	—	—	<p>BACK GROUND ERROR(VACUUM)</p> <p>When the Background is high at the time of Startup. 1.000×10^{-13}[A] and below</p>	<ol style="list-style-type: none"> 1) Did the large amount of He being absorbed during the last measurement? The concentration of He within the equipment is rising. Several operations of start/stop are needed
N28	u	—	—	<p>BACK GROUND ERROR(SNIFFER)</p> <p>When the Background is high at the time of Startup. 5.000×10^{-11}[A] and below.</p>	<ol style="list-style-type: none"> 1) Did He being used before startup of the equipment? The concentration of He within the environment rising. Find a place where He concentration. Is stable and execute restart.









N31	u	—	t	<p>SNIFFER PRESSURE TOO LOW CAUTION</p> <p>When injection pressure to Turbomolecular pump decreased. This error is read out only once per Testing. 20Pa and below</p>	<ol style="list-style-type: none"> 1) Check to see that the tip of the probe is not obstructed. Is sintered filter at the tip clear of any clogs? Replace the sintered filter if any clogging is detected. 2) Check the pressure of Test port when using Sniffer BS/BT unit. If the pressure is getting low, microseparator may be deteriorating. 3) Check the Sniffer probe tube for any bent areas. Make sure that the tube is not bent.
N32	u	—	t	<p>SNIFFER PRESSURE TOO HIGH CAUTION</p> <p>When injection pressure to Turbomolecular pump increased. This error is read out only once per Testing. 45Pa and above</p>	<ol style="list-style-type: none"> 1) Is the tip of probe free of any problems? Check the sintered filter for any disconnection. If disconnected, its reconnection is required. 2) Check the pressure of Test port when using Sniffer BS/BT unit. If the pressure is getting low, microseparator may be deteriorating. 3) Check the tube insider the Sniffer probe tube for any cuts. If so replace them.
N33	u	—	t	<p>SNIFFER FLOW TOO LOW CAUTION</p> <p>When Sniffer flow rate decreased. This error is read out only once per Testing. 0.5SLM and below</p>	<ol style="list-style-type: none"> 1) Check to see that the tip of the probe is not obstructed. Sintered filter may be clogged. Replace the sintered filter. 2) Check the Sniffer probe tube for any bent areas. Make sure that the tube is not bent when use. 3) Check to see that the exhaust port of the Sniffer unit is not obstructed.
N34	u	—	t	<p>SNIFFER FLOW TOO HIGH CAUTION</p> <p>When Sniffer flow rate increased. This error is read out only once per Testing. 7.5SLM and above</p>	<ol style="list-style-type: none"> 1) Is the sintered filter at the tip of the probe securely fixed? Reattach the sintered filter.

N40	—	—	t	<p>PRESSURE INCREASE</p> <p>When the pressure rose during testing.</p>	<ol style="list-style-type: none"> 1) The fixed Ultra Flow turns to error when it becomes 3Pa and over. In such a case, test with Fine Flow or Auto Flow. 2) The fixed Fine Flow turns to error when it becomes 150Pa and over. In such a case, test with Gross Flow or Auto Flow. 3) The fixed Gross Flow turns to error when it becomes 1800Pa and over.
W41	—	—	t	<p>TMP OVER LOAD</p> <p>When atmosphere exceeding the pressure capacity is injected during the test.</p>	<ol style="list-style-type: none"> 1) Possibility of injecting atmosphere exceeding the pressure capacity. Check to see if there are any malfunction in the connection of the test port and valve operation of the system etc.
W42	—	—	t	<p>EMISSION ERROR</p> <p>When atmosphere exceeding the pressure capacity is injected during the test.</p>	<ol style="list-style-type: none"> 1) Possibility of injecting atmosphere exceeding the pressure capacity. Check to see if there are any malfunction in the connection of the test port and valve operation of the system etc.
W910	—	—	—	<p>CPU Error</p> <p>When watchdog timer operated.</p>	<ol style="list-style-type: none"> 1) This error occurs when the equipment's program hangs up to improper state and regular watch dog operation could not be performed. Check again after reconnecting the power supply.
W920	—	—	—	<p>WIRELESS COMMUNICATION ERROR</p> <p>When error occurred in wireless communication.</p>	<ol style="list-style-type: none"> 1) Error occurred in wireless communication. Access the equipment and execute communication again.
W930	—	—	—	<p>WIRE COMMUNICATION ERROR</p> <p>When error occurred in wire communication.</p>	<ol style="list-style-type: none"> 1) Error occurred in wire communication. Check the connection points of cables and check the cables.

*Refer to Maintenance Section 10, for error messages regarding maintenance inspection and replacement of parts.

10. Maintenance

There are some equipment/parts used in this equipment require periodical maintenance and replacement. Some parts deteriorate after prolonged use and must be replaced in the vent of failure. The maintenance and replacement procedures are described below.

 WARNING	<p>Power Shutdown When installing the equipment or removing the external panels for inspection and replacement of parts, turn off the MAIN POWER switch and disconnect plug from the outlet before operating. Possibilities of electric shock and damages to the equipment due to high voltage areas.</p>
 CAUTION	<p>High Temperature Warning The pump, analyzer tube, and solenoid valve are extremely hot immediately after stopping. When inspecting/replacing parts, wait for 15 minutes or more after stopping and then proceed carefully with the work. Risk of injury from burns and the possibility of damage to the equipment.</p>
 CAUTION	<p>Overhaul Parts (O-ring and drive parts) used inside of the equipment, including consumables, are subject to deterioration over time. To maintain the performance of the equipment, make sure to execute periodical overhaul. A period of once a year is recommended.</p>
 CAUTION	<p>Do Not Use Grease Grease is not used for piping joints and valve interiors of the equipment. Do not use grease when disassembling and assembling. It may cause malfunction of the equipment and may lead to damage of components.</p>
 CAUTION	<p>Do Not Touch Vacuum Components Components exposed to vacuum in the equipment and component surfaces that face the vacuum have been treated with precision cleaning and are maintained in a clean state. Do not touch these components with bare hands but use rubber gloves when disassembling/assembling. Risk of reduced performance of the equipment.</p>
 CAUTION	<p>Removal of Dust O-rings are use for piping joints. Remove any dust on the O-ring before disassembling and assembling. Use alcohol to clean away any sweat or oil on the parts. It may cause malfunction of the equipment and damage to the components.</p>
 CAUTION	<p>Maintenance in Charge Trained maintenance staff are to perform any task for maintenance.</p>
 CAUTION	<p>Disposal When disposing the unit or a portion of the unit, refer to local laws and ordinances. When toxic gas is used, the unit must be disposed through an industrial disposal specialist. The cost incurred to the disposal will be covered by the customer.</p>

10-1 List of Maintenance Items

The following components require periodical maintenance. Refer to maintenance procedure for each component for operation.

Component Name (model installed)		Task	Frequency	Type
Fore Pump	Rotary Pump (901W1, 904W2)	Replacement of oil	1 per 6 month	W1(GHD-031):R-2 W2(GLD-136):SMR-100
	Scroll Pump (901D2, 904D3)	Overhaul	1 per year or per 8000 hrs operation	(*1)
	Diaphragm Pump (Unit BS/BT)	Replacement of pump	1 per10000hrs	
Turbomolecular Pump	Replacement of wick holder	1 per2 years		
		Overhaul	1 per2 years	
Pirani Gauge Head	Replacement of gauge head	When disconnected or deteriorated	WP-01	
Ion Source	Replacement of Ion source	When disconnected or deteriorated	IS-BA1	
Calibration Leak	Recalibration	Set by client	CLM-08F	
Sniffer Probe tip Sintered Metal Element	Replacement of Sintered metal element	When dirty, clogged	ESD-4-2-10	
Sniffer Unit BS/BT	Replacement of microseparator	When dirty, clogged	MS-80	
Sniffer Unit BS	Replacement of dust filter	Decreased flow rate	VFJ44	
Sniffer Unit BT	Replacement of dust filter	Decreased flow rate	A1019E	
Internal Fan Filter of the	Replacement of fan filter	When polluted	109-1003M40	
Intake Fan Filter	Replacement of fan filter	When polluted	FE-462-2-F4	
Oil Mist Filter, (901W1)	Replacement of element	When polluted	M1000-KIT	
Vent Filter	Replacement of fan filter	When polluted	ZFC-EL-4	
Analyzer Tube	Surface treatment	When deteriorated	(*1)	
Piping	Cleaning	When polluted		
Valve Plunger	Replacement	When deteriorated		
O-rings	Replacement	When deteriorated		

(*1) Request your overhaul, cleaning or replacement of part of components to your nearest Service Desk. When returning the main equipment for maintenance and repair, fill in the Pollution Identification Form with the following details; any inclusion of toxic substances in the equipment, or devices are polluted. In case the equipment is polluted, indicate the nature of danger in detail. The Pollution Identification Form can be found in the last page of this manual. This form must be either attached or enclosed with the equipment.

*Parts (O-rings, drive parts) used inside the equipment, including consumables, are subject to deterioration over time. In order to maintain its performance periodical overhaul is needed. A cycle of once per year is recommended.

10-2 Maintenance Procedures

10-2-1 How to Install/Remove External Panels

For maintenance, first the external panels need to be removed according to a given order. The following describes the method of removing each panel.

**WARNING****Power Shutdown**

When installing the equipment or removing the external panels for inspection and replacement of parts, turn off the MAIN POWER switch and disconnect the plug from outlet before operating. Possibilities of electric shock and damages to the equipment due to high voltage areas.

(1) Top panel

- 1) Remove the flexible hose connected to the Test Port and the clamp which secures chambers.
- 2) Catch the top panel removing part located in the left panel surface with your finger and lift it up as shown by the arrow.



(2) Rear Panel

- 1) Face the panel to the direction of the arrow and remove it.

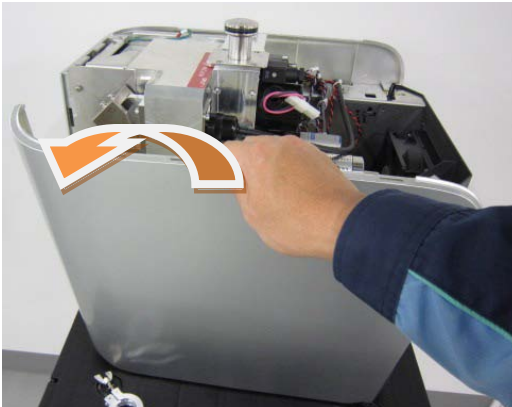

All replacement maintenance is possible by removing top and rear panels.

(3) Attachment

- 1) To replace the panels, attach them by using the reverse sequence of removing panel procedure.

10-2-2 Rotary Pump

(1) Areas of inspection

- 1) Oil level: Fill with oil between 50 to 80 % of the view port.
- 2) Oil wear: Check for discoloration and dust interfusion.

(2) Inspection Procedures

- For model 901W1 -

A view port is located at the lower area of the left panel. Check the oil level and oil wear through this view port.

- For model 904W2 -

Rotary Pump is located on the mobile cart. The oil view port is located at the handle part of the mobile cart. Check for oil level and oil wear through this view port.

(3) Oil Replacement Procedures

- For model 901W1 -

- 1) Turn OFF the main power supply switch and make sure to remove the power supply cable from the main unit.
- 2) Remove the top and rear panels. Refer to the procedure for removing external panels (Section 10-2-1) for removal method.
- 3) Remove the cap attached to the end of drain tube and drain out the oil into an oil pan placed under the tube end. (Approximately 370 ml oil will be drained). Attention must be paid to protect floors from oil spillage.

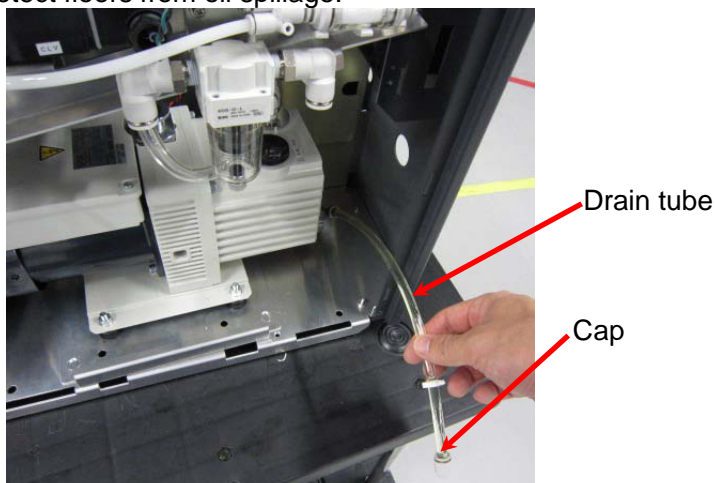

- 4) When the oil is completely drained, turn the tube end upwards. Use a funnel and pour in oil through the tube. The amount of oil is to be 80% when viewed through the view port. The type of oil used is R-2.
- 5) Replace the cap when the oil is filled.
- 6) Replace the panels removed.

- For model 904W2 -

- 1) Remove oil drain cap and connect hoses. Remove the oil intake cap. Place an oil drain pan at the end of the hose and drain the oil by turning the drain faucet. (Approximately 1 liter of oil is drained) When the oil has finished draining, close the drain faucet.



- 2) Pour in oil into the intake port (photo above) until it reaches approximately 80% of the view port. The type of oil used is SMR-100.
- 3) When the oil is filled, replace the drain faucet and the cap of the oil intake port.

In order to main the equipment in good condition, oil replacement of every 6 months is recommended.

10-2-3 Pirani Gauge Head

(1) Areas of Inspection

1) Check for disconnection of Pirani Gauge Head

There should be an electrical continuity between one pin of group A and one pin of group B of the following diagram. (Approximately $13\ \Omega$ within the atmosphere)



CAUTION

Over Voltage to Filament

Risk of disconnection if 2mA or more overload current is applied to the filament. Be careful of current value of measurement device.

Measurement must be made in atmospheric pressure because filaments will be heated in vacuum environment and correct measurement of resistance value is not possible.

(2) Inspection Procedures

- 1) Turn OFF the main power supply switch and make sure to remove the power supply cable from the main unit.
- 2) Remove the top and rear panels. Refer to the procedure for removing external panels (Section 10-2-1) for removal method.
- 3) Turn the clamp stop screw of detection part (SPU) connected to Pirani gauge head and loosen the clamp. Remove the detection part.

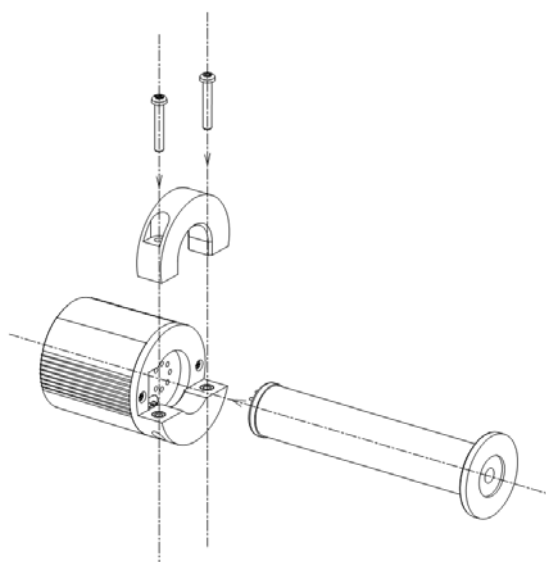

- 4) Check the electrical continuity. If no electrical continuity is found, there is a possibility of disconnection of Pirani gauge head. Replacement of Pirani gauge head is needed. (Refer to replacement procedures)

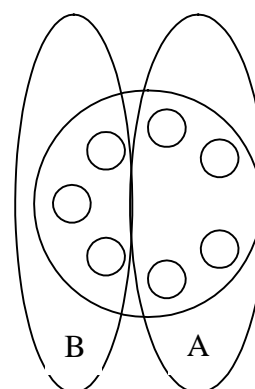
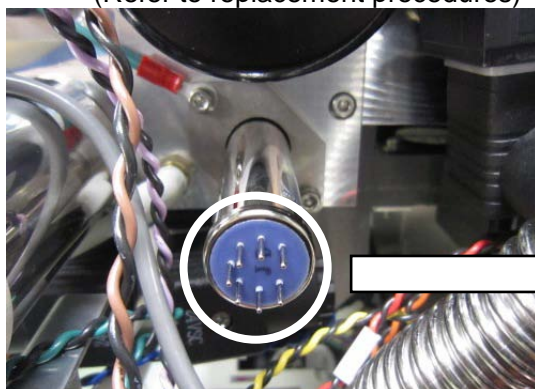

(3) Replacement Procedure

- 1) Turn OFF the main power supply switch and make sure to remove the power supply cable from the main unit.
- 2) Remove the top and rear panels. Refer to the procedure for removing external panels (Section 10-2-1) for removal method.
- 3) Turn the clamp stop screw of detection part (SPU) connected to Pirani gauge head and loosen the clamp. Remove the detector part.
- 4) Unscrew Allen-head bolts (2 locations: 4x10) anchoring the flange of Priani gauge head. Special caution is required to perform the task due to limited working space.
- 5) Remove anchoring flange and O-ring from the gauge head removed

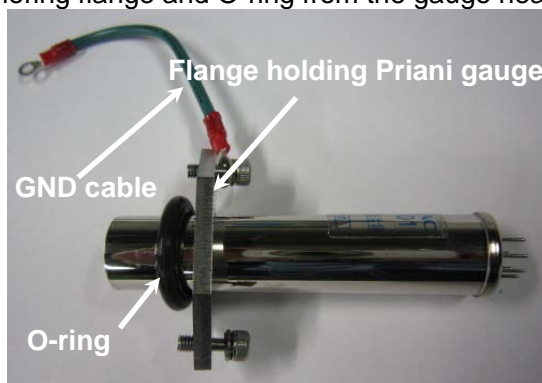

- 6) Replace with the new gauge head and fix anchoring flange of the gauge head and O-ring.
- 7) Assemble the gauge head by using reverse procedure to assembling.
- 8) If the gauge head is not securely inserted to the end of detector area as illustrated below, gauge head may cause leakage due to clamp tightening. When securing detector (SPU) clamp, place GND cable in between the stopping screw.

Insufficient plug in (generation of leaks)

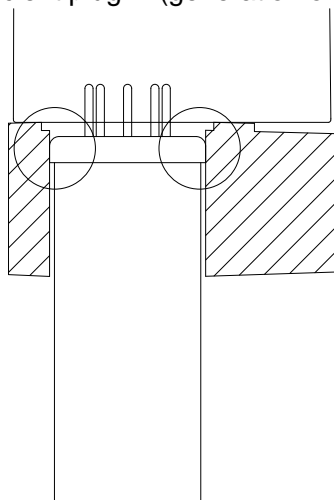

Sufficient plug in

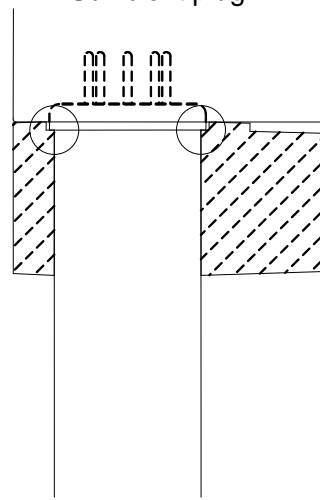
**CAUTION****Caution Handling Pirani Gauge Head**

Pirani gauge head is connected to the turbomolecular pump. When the Pirani Gauge Head is removed, be careful not to allow dust interfusion of the turbomolecular pump. Mechanical shocks subjected by dropping may cause error to its operation due to disconnection.

10-2-4 Ion Source

(1) Areas of Inspection

- 1) In case of disconnection error of filament.
- 2) In case of sensitivity error.
- 3) 2 Filaments of Filaments 1 and 2 are installed. Only when Filament 1 is disconnected, it automatically switches to Filament 2. In such a case preparation of ion source replacement is recommended. Filament numbers selected can be checked by Fil.*display on the upper area of the screen.

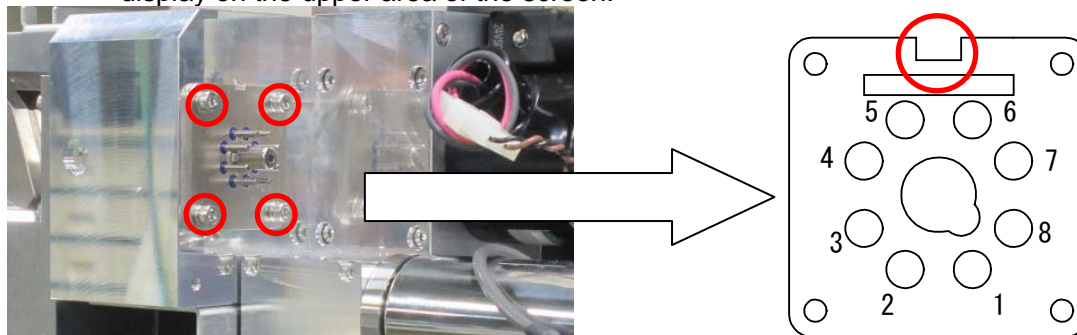

(2) Replacement Procedure

- 1) Turn OFF the main power supply switch and make sure to remove the power supply cable from the main unit.
- 2) Remove the top and rear panels. Refer to the procedure for removing external panels (Section 10-2-1) for removal method.
- 3) Remove the connector which is connected to the ion source by pulling out the connector.
- 4) The ion source is fixed as shown in the photo and illustration above. Remove the Allen-head bolts (4 locations: M4x10) fixing the ion source.
- 5) Fix the new ion source with Allen-head bolts (4 locations: M4x10). When installing the ion source place so that the cutout area (red circled area of the top right diagram) comes to the top. Attention must be paid to the facing direction of the ion source when fixing it.
- 6) Plug in the connector to the ion source.
- 7) Replace the panels removed.



CAUTION

Caution Handling Ion Source

Ion Source has been treated with precision cleaning. Do not touch the interior with bare hand when replacing ion source. Risk of malfunction of the equipment and may lead to damage of components.

10-2-5 Calibration Leak

(1) Replacement Procedure

- 1) Turn OFF the main power supply switch and make sure to remove the power supply cable from the main unit.
- 2) Remove the top and rear panels. Refer to the procedure for removing external panels (Section 10-2-1) for removal method.
- 3) Cut the insulation lock ties (refer to the photo below) securing the temperature sensor to the calibration leak with nippers. Be careful not to damage the temperature sensor.

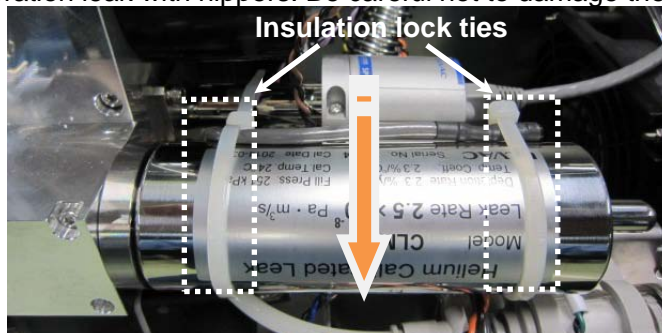

- 4) Remove the calibration leak by loosening it by anticlockwise rotation (direction of arrow). Be careful not to drop the calibration leak. Also, make sure to remove the O-ring between the calibration leak and turbomolecular pump.
- 5) Secure tightly the new calibration leak by clockwise motion. Make sure to insert the O-ring.
- 6) Secure the temperature sensor with an insulation lock (not less than 200mm long) on the tube surface of the calibration leak.
- 7) Replace the panels removed.



CAUTION

Caution Handling Calibration Leak

Calibration leak is connected to turbomolecular pump. When removing the calibration leak make sure that turbomolecular pump is not subjected to dust interfusion. Any severe shock subjected, such as dropping will break the calibration leak. Special care must be taken for handling of the calibration leak.

10-2-6 Sintered Metal Element of Sniffer Probe Tip

- (1) Areas of Inspection
 - 1) The Sintered Filter should be free from dirt or clogs.
- (2) Inspection Procedure
 - 1) Replacement is necessary if caution error (decrease in injection pressure or increase in injection pressure) (decrease and increase in flow rate of Sniffer Unit BS) occurs frequently during Sniffer test.
- (3) Replacement Procedure
 - 1) Remove the securing screw of Allen-head bolt in the Sniffer probe tip by using 2.5mm hexagonal wrench key.
 - 2) By tilting the tip of Sniffer Probe, disengage the sintered metal element.
 - 3) Put the following components in order of New sintered metal element and resin washer and secure with a lock screw with hexagon hole.



10-2-7 Microseparator (Sniffer Unit BS/BT only)

- (1) Areas of Inspection
 - 1) Replace is necessary when caution error (decrease in injection pressure or increase in injection pressure) is indicated.
- (2) Replacement Procedure
 - 1) Remove the NW25 clamp of Sniffer Unit BS/BT connected to the test port.
 - 2) Replace with a new microseparator attached between the test port flange and Sniffer Unit BS/BT. Refer to the photo below for attachment face.



- 3) Place the test port to the Sniffer Unit BS/BT and secure them with NW25 clamp.

10-2-8 Dust Filter (Sniffer BS Unit only)

(1) Areas for Inspection

- 1) Replace it when caution error (decrease in injection pressure or decrease in flow rate) is indicated.

(2) Replacement Procedure

- 1) After removing the NW25 clamp of Sniffer Unit BS Unit connected to the test port, remove the cover of Sniffer Unit BS. Truss head screw (6 locations: M5x10)



- 2) Remove the inline filter connected to the tube inside and replace it with a new inline filter.

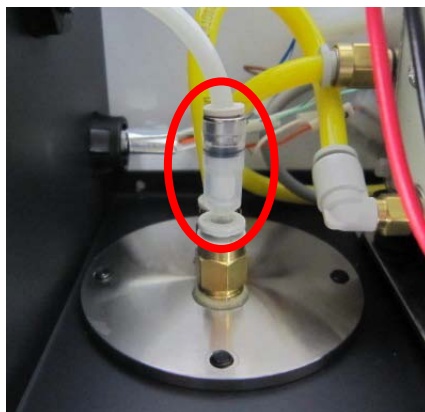

- 3) After attaching the cover of Sniffer Unit BS, connect it to the test port.

10-2-9 Dust Filter (Sniffer Unit BT only)

(1) Areas for Inspection

- 1) Replace it when caution error (decrease in injection pressure or decrease in flow rate) is indicated.

(2) Replacement Procedure

- 1) Remove the NW25 clamp of Sniffer Unit BT connected to the Test Port.



- 2) Replace with a new filter by turning the clear bowl of filter area to clockwise and also removing the internal filter with a screw.
- 3) Attach the filter bowl and connect it to the test port.

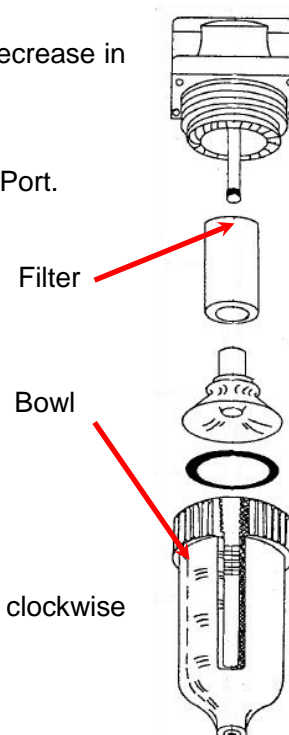

10-2-10 Fan Filter Inside the Equipment

(1) Areas for Inspection

- 1) Replace when filter is dirty.

(2) Replacement Procedure

- 1) Turn OFF the main power supply switch and make sure to remove the power supply cable from the main unit.
- 2) Remove the top and rear panels. Refer to the procedure for removing external panels (Section 10-2-1) for removal method.
- 3) The fan filter is located at the front panel as shown in the photo below.

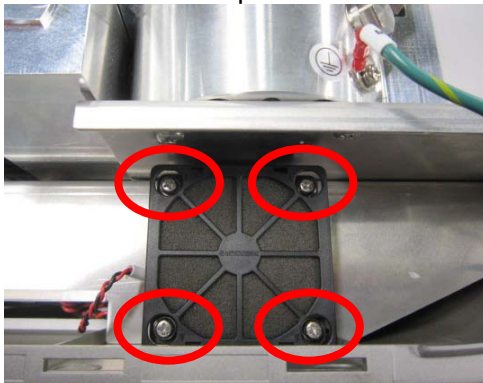

- 4) Remove the cover of the fan filter by lifting it up.
- 5) Replace the fan filter and attach the cover removed in 4)
- 6) Attach the panel removed.

10-2-11 Intake Fan Filter

(1) Areas for Inspection

- 1) Replace when filter is dirty.

(2) Replacement Procedure

- 1) Turn OFF the main power supply switch and make sure to remove the power supply cable from the main unit.
- 2) Remove the surface cover by sliding a slotted screw driver to the click releasing hole as shown in the photo.



- 3) Replace the filter and attach the front cover removed in 2)

10-2-12 Mist Oil Filter

(1) Areas for Inspection

- 1) Replace when the element becomes dirty.
- 2) If oil is already accumulated inside the bowl, the inside must be cleaned.

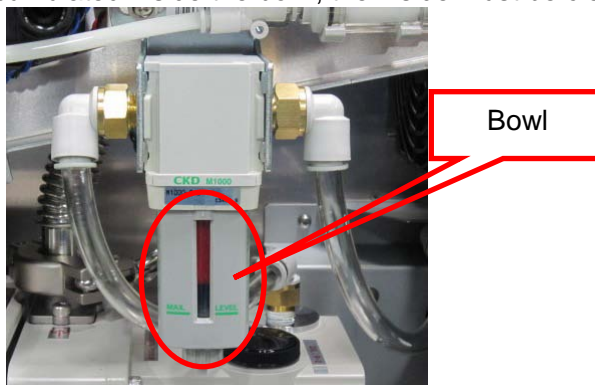

(2) Replacement Procedure

- 1) Turn OFF the main power supply switch and make sure to remove the power supply cable from the main unit.
- 2) Remove the top and rear panels. Refer to the procedure for removing external panels (Section 10-2-1) for removal method.
- 3) Turn the bowl of the oil filter 45 degrees to the left remove the filter. Be careful not to spill any oil accumulated in the bowl.



- 4) Turn the mantle by turning it to the left.
- 5) Attach O-ring to the mantle and install the mantle to the body. The attachment of the mantle should be to a position where the end of the mantle touches (until it feels slightly solid).
- 6) Attach the bowl of oil filter to the body.
- 7) Attach the rear panel and top panels.

(3) In this case?

- 1) If oil accumulates frequently in the oil mist filter or gives adverse impact to measurement, remove IN/OUT tube of the oil mist filter, connect a tube with straight type joint for 10φ to create a state where no filter is required.



- 2) Possibility of exhausting oil mist from PUMP EXHAUT of connector panel if the filter is removed.

10-2-13 Vent Filter

(1) Areas for Inspection

- 1) Replace when the element becomes dirty.

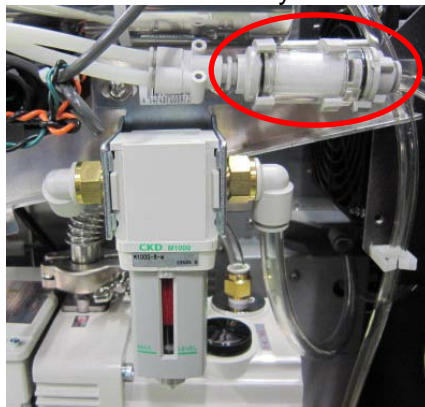

(2) Replacement Procedure

- 1) Turn OFF the main power supply switch and make sure to remove the power supply cable from the main unit.
- 2) Remove the top and rear panels. Refer to the procedure for removing external panels (Section 10-2-1) for removal method.
- 3) Remove the filter part from the bracket.
- 4) Disengage the tube with a single touch of the joint.
- 5) Release the lock by sliding the rotation stopper to the direction of allow.
- 6) Rotate the cover 90 degrees anticlockwise.
- 7) Take out the element by pulling out the cover from the case. As for the dust piled up within the case, remove them by air blower.
- 8) Attached a new element to the cover, and fit it into the case.
- 9) Turn the lug of the cover until it meets the part numbers of the case side, push in the cover until it touches against the end, and turn it clockwise until it stops.
- 10) Return the rotation stopper to the locked position and make sure that the cover is locked.
- 11) Assemble the equipment by reverse procedure of the above.

Lock released position

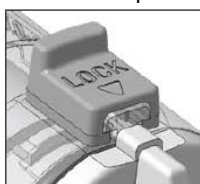

Locked position

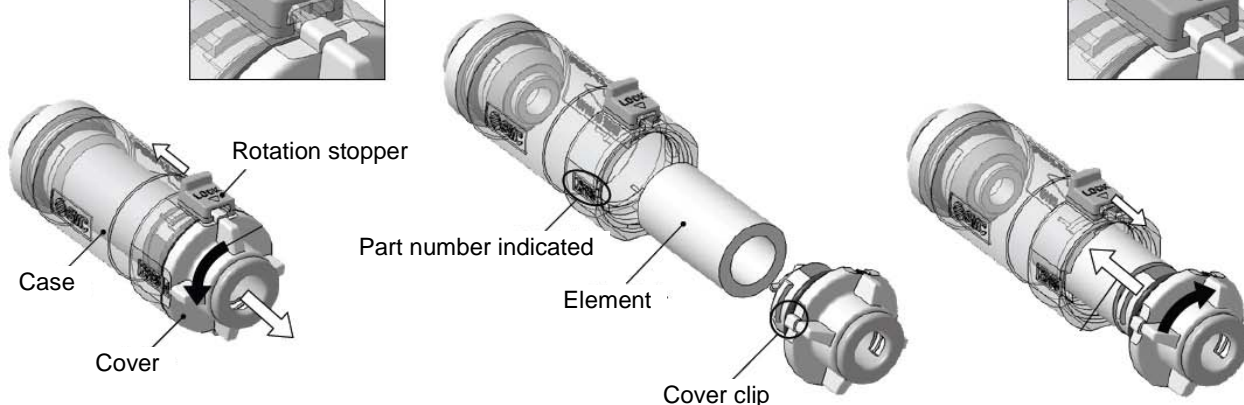
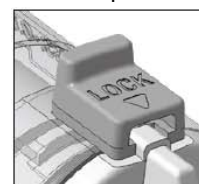





11. Input/Output Signals

Input/output signals are operated with 4 types of connectors; EXT.I/O (external control), LEAK RATE (Leak Rate output), RS-232C (Printer connection and RS232C communication), and display/RS485 (RS-485 communication). The following list describes each of these functions and their usage procedure.

11-1 EXT.I/O

To output the condition of equipment and to receive external control signals.

 CAUTION	<p>Load Always provide a load between pins used for output of signals and power supply. Check ON/OFF of output signal by operating the load. Risk of damage to the equipment if no load is provided.</p>
 CAUTION	<p>Maximum Current The maximum current to be passed to the load of output signal should be not be more than 50 mA. Exceeding 50 mA may cause damage to the equipment.</p>
 CAUTION	<p>Maximum Voltage The voltage applied to the input signal pins should be within the range of DC +20 to 30 V. (Recommended value DC +24 V) If voltage outside of this range is applied, the equipment may be damaged.</p>
 CAUTION	<p>Electric Short Circuit of Pins Prohibited The maximum of DC +24 V is applied to the input/output pins. Do not under no circumstances short circuit between pins and GND level or short circuit the pins between them. Risk of damaging the equipment.</p>
 CAUTION	<p>One-Shot Input The input time of one-shot input should not be less than 1 second. Risk of malfunction if the input time is short.</p>

11-1-1 List of Output Signals

No	Signal Name	I/O	Description (Set at Normally Open)
1	SETPOINT1	OUT	Outputs this signal when leak rate exceeds set point 1 – 3. Maintains the output until the next TEST START signal is entered.
2	SETPOINT2		
3	SETPOINT3		
4	Roughing/Testing		Outputs from start of roughing until the end of the test. (It does not output during Standby).
5	ERROR1		Starts output from the time warning error starts, and turns OFF the output in parallel with error release.
6	Over Range		Outputs when the maximum leak detection capacity exceeds. It also outputs when measurement range exceeds in the test screen.
7	ERROR2		Output begins at the moment when caution error occurs and the output turns OFF in parallel with the release of error mode. When [INVALID] is selected with [MESSAGE] – [NOTICE] (Section 5-2_6) this output is not read out.
8	TV3 OPEN		Outputs when valve TV3 opens.
9	He Spray		He spray signal during cycle test (Section 8-2-1)
10	START UP		Outputs signal during startup. Also outputs during sensitivity recalibration. After completing the startup the signal turns OFF.
11	AUTO ZERO		An output signal when the Auto Zero is at ON.
12	Testing		An output signal when leak rate is displayed after starting the test. It does not output signal during Roughing.
13	STANBY		An output signal read out when startup is completed and turned into Test standby mode. This signal is read out until it turns to stop operation mode. However, it does not output any signal during sensitivity recalibration
14	CLEAN UP		An output signal during cleanup
15	<, –		When the Auto Zero is set at [1SHOT] (Section 5-1_4), outputs signal if measurement value reaches the minimum display value or below. When the Auto Zero is set at [ALTERNATE] (Section 5-1_4), outputs the signal if measurement value reaches to a minus display. This is an output signal during testing.
16	EXT.CLV	OUT	This is an output signal to operate external calibration leak valve when external calibration leak [GENERAL] – [CALIBRATION] – [START-UP] (Section 5-1_7)) and automatic [CALIBRATION STANDARD] – [EXTERNAL CALIBRATION LEAK (FOR VACUUM METHOD)] – [VALVE CONTROL] are selected. The maximum current is 1A.
17	EXT.CLV COM		Remote controller for pin 16.
34 35	-COM	IN	Remote controller for output signal.

*When the I/O output signal setting at [EXT.I/O] (Section 5-3_5) is selected as [NO], the operation will be as explained above. When [NC] setting is selected, the output will be in reverse with above operation.

- (1) Output signals
- 1) Output signal outputs on a steady basis.
 - 2) Output is an open collector output of emitter common. The emitter common is 34, and 35 pin (-COM).
 - 3) The output rating is [DC + 20 to 30 V (+24V recommended) 50mA_{MAX} saturated voltage]
 - 4) Place a load between each pin and power supply. Check the ON/OFF of the output signal by operation of the load.

An example of output current is shown below. Construct an input/output circuit with reference to the circuit example.

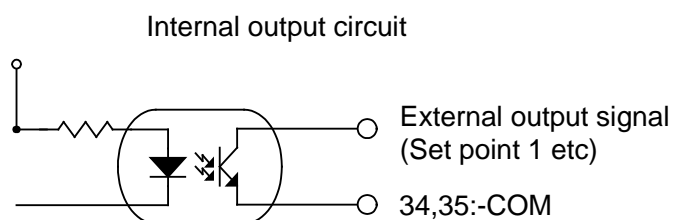

11-1-2 List of Input Signals

№	Signal Name	I/O	Description
18	EXT.POWER DC24V	OUT	Power supply output of DC 24V maximum current 2A
19			
20	SYSTEM START/STOP	IN	Start and stop input signal of the equipment Activates when changed from high to low. Stops when changed from low to high
21	TEST START/STOP		Start and stop input signal of test. When changed from high to low: Starts testing When changed from low to high: Stops testing When cycle test is selected, one cycle test is executed by pulse input from high to low. Input is possible only during Test standby mode
22	unassigned		Unused.
23	unassigned		Unused.
24	unassigned		Unused.
25	Re- CALIBRAITON		Input signal for Sensitivity Recalibration. As for the input signal, enter pulse input from high to low. Input is possible only during Test standby mode
26	AUTO ZERO		Input signal for Auto Zero. When [1SHOT] is selected for setting, the input signal must be entered with pulse input of high to low. At [ALTERNATE] setting: When changed from high to low: ON When Changed from low to high: OFF Input is possible only during Test standby mode
27	PRINT		Input signal to print out leak rate. As for the input signal, enter pulse input from high to low. Input is possible only during Test standby mode
28	Error Reset		Reset input signal for errors occurring in the equipment. As for the input signal, enter pulse input from high to low. The input signal can only be entered during error condition.
29	HOLD INDICATION		Input signal to show leak rate display as Hold. When changed from high to low: in Hold mode When changed from low to high: Hold released Input is possible only during Test mode.
30	CLEAN UP		Input signal for clean up. As for the input signal, enter pulse input from high to low. Input can be executed any time except during Startup.
31	Peak Hold	Input signal of the maximum value of leak rate hold. When changed from high to low: Hold mode at maximum value of leak rate from the point. When changed from low to high: Release of maximum value. Input is possible only during Test mode.	
32	+COM		Remote controller for Input signal. Enter DC +24 V
33			
36	EXT.POWER 0V	OUT	Output common (SG) for pins 18 and 19
37			

(1) Input Signals

- 1) Input voltage of Pin +COM 32, 33 is DC+20 to 30V (+24 V recommended)
- 2) Place a junction or open collector between input signal and GND. Input the signal by operation of the junction.
- 3) Pulse input of not less than 1 second per pulse is to be entered.
- 4) When using EXT. POWER DC 24 V, construct the circuit so as to allow current flow of less than 2A.
- 5) If current of 0.1 mA or over passes between each input signal pin and +COM terminal, the internal circuit of the equipment may process it as signal input (terminal short circuit).
- 6) After activation of power supply, SYSTEM START/STOP signal of No. 20 must have elapse time of more than 30 seconds before entering the start signal. The equipment may not start operating if the input is executed earlier than 30 seconds.

An example of input current is shown below. Construct an input/output circuit with reference to the circuit example.

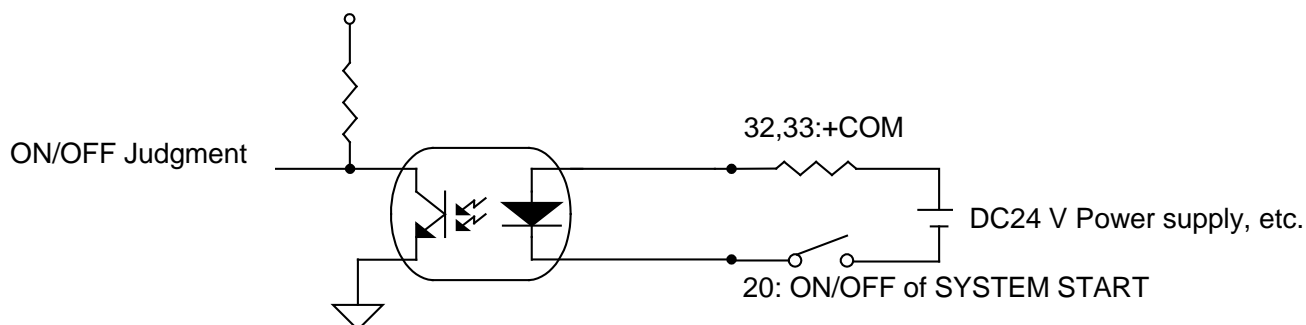

11-2 LEAK RATE

Voltage output of leak rate and test port pressure. The voltage output is DC 0 V to 10 V. Use this voltage by connecting to PLCs and pen recorders.

11-2-1 Output Pin Number

Terminal	Description	Signal
2	Leak rate mantissa portion output +	DC 0~10 V
7	Leak rate mantissa portion output -	
3	Leak rate exponent portion output +	DC 0~10 V
8	Leak rate exponent portion output -	
4	Test port pressure LOG output +	DC 0~10 V
9	Test port pressure LOG output -	

*At the LOG setting, the same output signal will come from 2 to 7, 3 to 8.port and read out.

11-2-2 Output Table

11-2-2-1 Leak Rate Mantissa Portion Output Table

Output Voltage (V)	All Units (except for %xR)		%xR	
	Measured Value	Display Value	Measured Value	Display Value
9.99	9.99E-**	9.9E-**	99.9% **R	99% **R
9.00	9.00E-**	9.0E-**	90.0% **R	90% **R
8.00	8.00E-**	8.0E-**	80.0% **R	80% **R
7.00	7.00E-**	7.0E-**	70.0% **R	70% **R
6.00	6.00E-**	6.0E-**	60.0% **R	60% **R
5.00	5.00E-**	5.0E-**	50.0% **R	50% **R
4.00	4.00E-**	4.0E-**	40.0% **R	40% **R
3.00	3.00E-**	3.0E-**	30.0% **R	30% **R
2.00	2.00E-**	2.0E-**	20.0% **R	20% **R
1.00	1.00E-**	1.0E-**	10.0% **R	10% **R
0.00	0.00E-**	0.0E-**	00.0% **R	00% **R

11-2-2-2 Leak Rate Exponent Portion Output Table

Output Voltage (V)	Pa·m3/s	mbar·L/s Torr·L/s atm·cc/s	lusec	sccm	Mol/s
10.00	E-03	E-02	E+01	E-01	E-07
9.00	E-04	E-03	E+00	E-02	E-08
8.00	E-05	E-04	E-01	E-03	E-09
7.00	E-06	E-05	E-02	E-04	E-10
6.00	E-07	E-06	E-03	E-05	E-11
5.00	E-08	E-07	E-04	E-06	E-12
4.00	E-09	E-08	E-05	E-07	E-13
3.00	E-10	E-09	E-06	E-08	E-14
2.00	E-11	E-10	E-07	E-09	E-15
1.00	E-12	E-11	E-08	E-10	E-16

Output Voltage (V)	Oz/a	g/a	%xR	Amp.	ppm
10.00	E+00	E+01		E-07	E+06
9.00	E-01	E+00		E-08	E+05
8.00	E-02	E-01		E-09	E+04
7.00	E-03	E-02	10 ⁶ R	E-10	E+03
6.00	E-04	E-03	10 ⁵ R	E-11	E+02
5.00	E-05	E-04	10 ⁴ R	E-12	E+01
4.00	E-06	E-05	10 ³ R	E-13	E+00
3.00	E-07	E-06	10 ² R	E-14	E-01
2.00	E-08	E-07	10 ¹ R	E-15	E-02
1.00	E-09	E-08	10 ⁰ R	E-16	E-03

11-2-2-3 Quasi LOG Output Table of Test Port Pressure

The relational expression between test port pressure and output voltage of REC OUT is as below.

$$LR=10(V-E)\times 10^{-(6-E)}$$

LR : Pressure value

V : REC.OUT Output voltage

E : Value rounded off decimal points form REC.OUT Output voltage

Output voltage (V)	All pressure unit
9.99	9.9E+3
9.10	1.0E+3
8.99	9.9E+2
8.10	1.0E+2
7.99	9.9E+1
7.10	1.0E+1
6.99	9.9E+0
6.10	1.0E+0
5.99	9.9E-1
5.10	1.0E-1
4.99	9.9E-2
4.10	1.0E-2
3.99	9.9E-3
3.10	1.0E-3
2.99	9.9E-4
2.10	1.0E-4
1.99	9.9E-5
1.10	1.0E-5
0.99	9.9E-6
0.10	1.0E-6

11-2-2-4 Leak Rate LOG Output Table

Leak rate LOG output voltage will be a different output due to measurement range set.
The relation between leak rate and output voltage is as below.

$$V = \frac{9}{A - B + 3} \left(\log_{10} LR + \frac{A - 10B + 21}{9} \right)$$

$$LR = 10^{\frac{(V-1)A + (10-V)B + 3V - 21}{9}}$$

A: A: Measured range, MAX setting of 9.99E+A

B: B: Measured range, MIN setting of 0.01E+B

LR: LEAK RATE

V: OUTPUT [V]

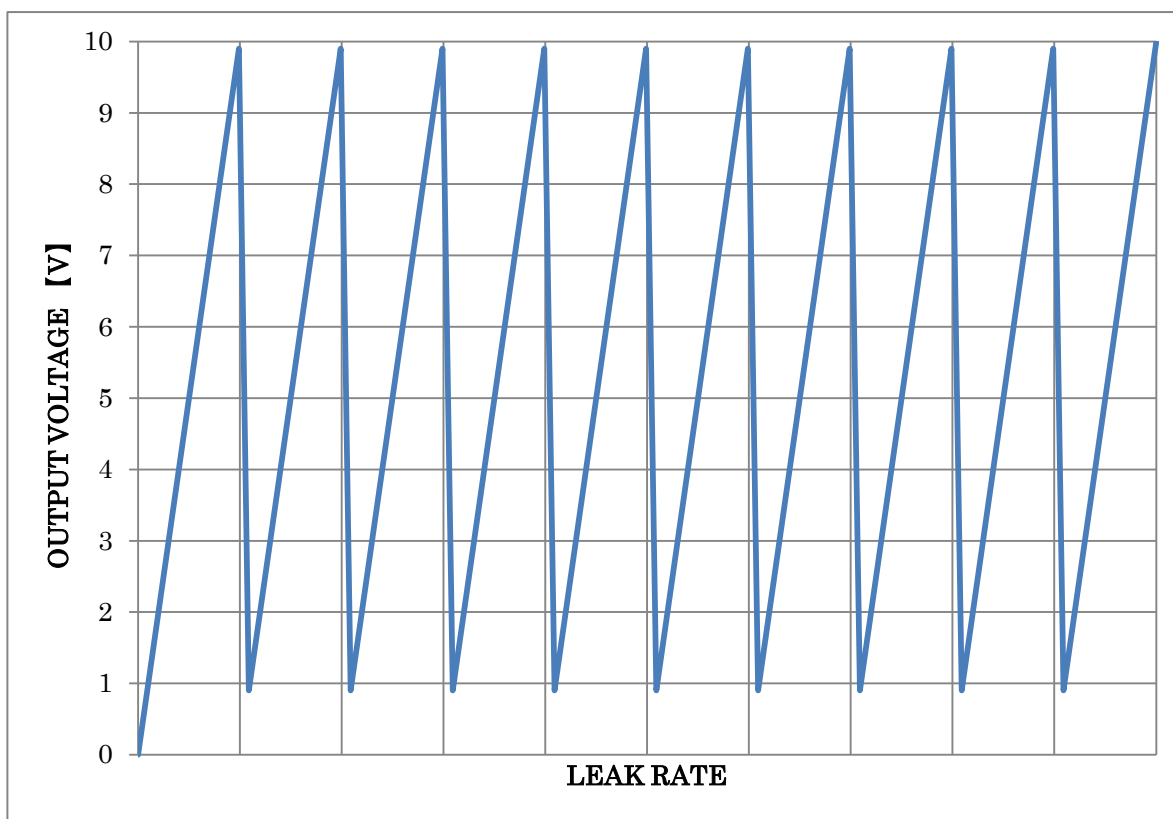
11-2-2-5 Recorder Output Graph (Leak Rate Mantissa portion output)

11-2-2-6 Recorder Output Graph (Leak Rate an exponent portion output)

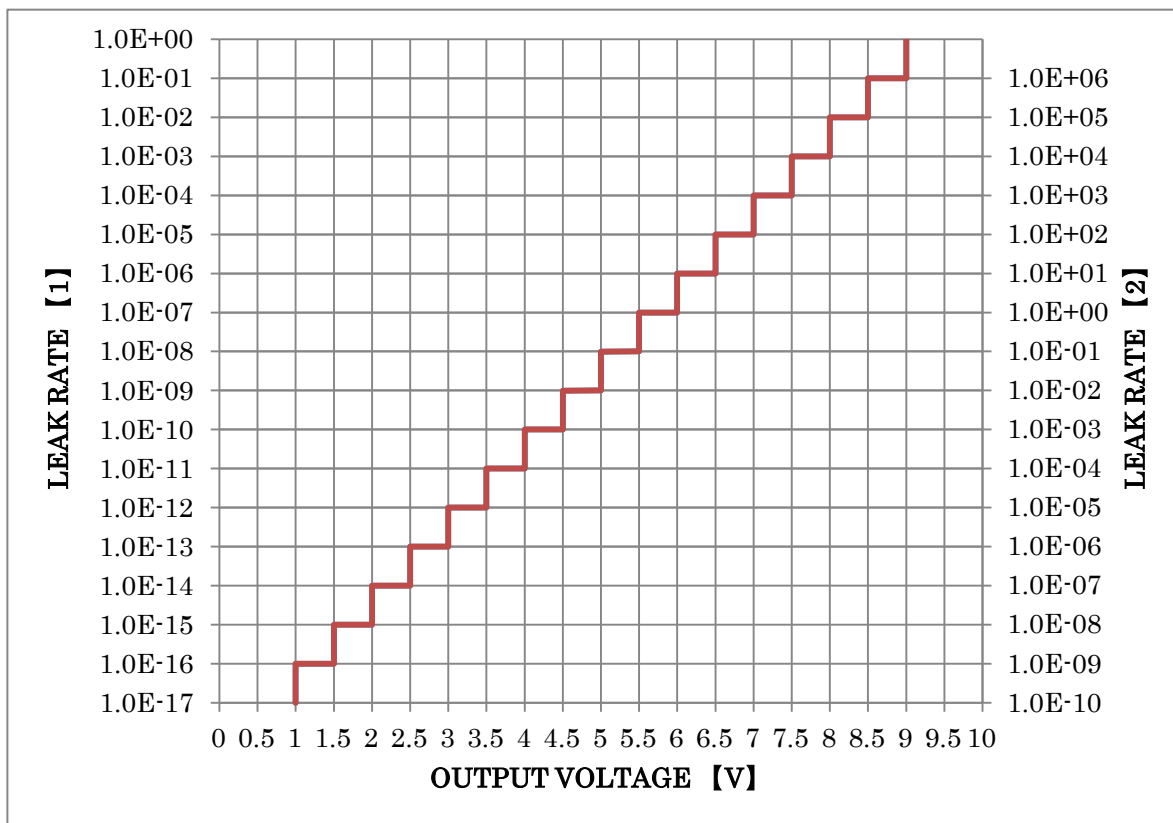

11-2-2-7 Recorder Output Graph (Test port pressure quasi LOG output)

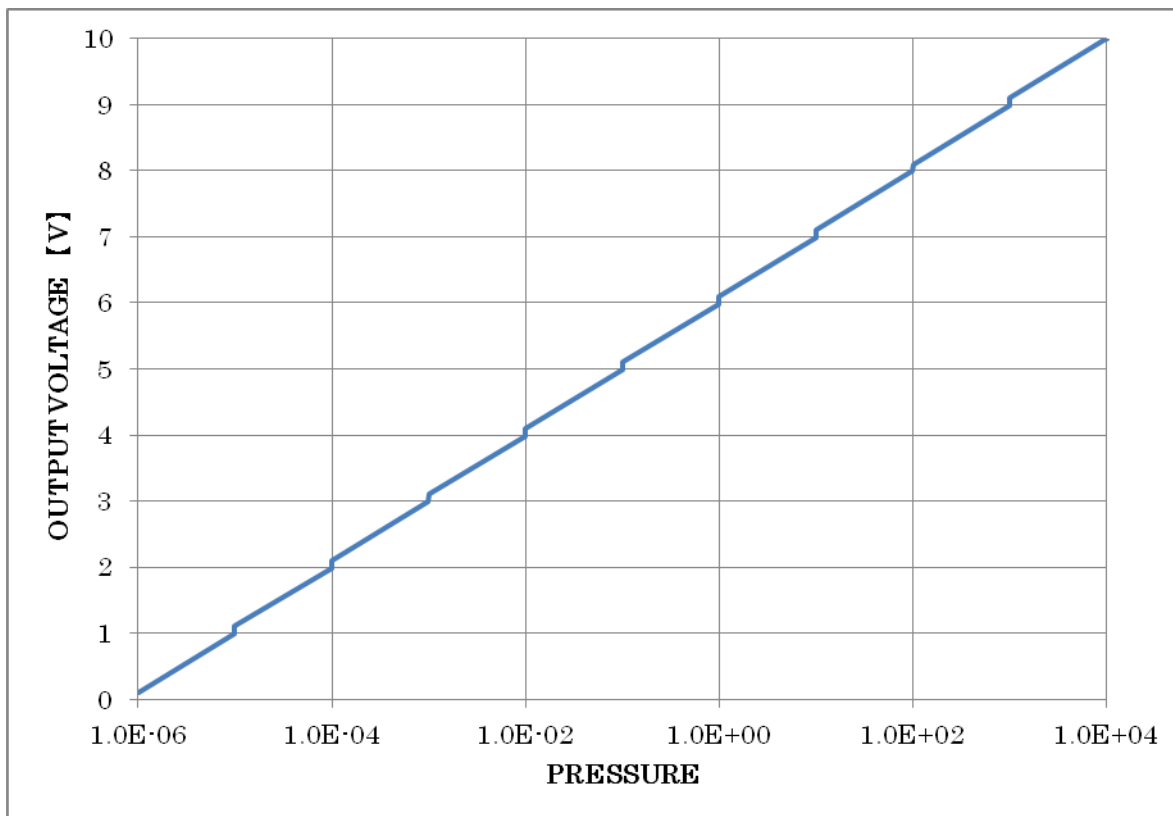

11-2-2-8 Recorder Output Graph (Leak Rate LOG Output)

Example) A=-3, B=-12 Set time

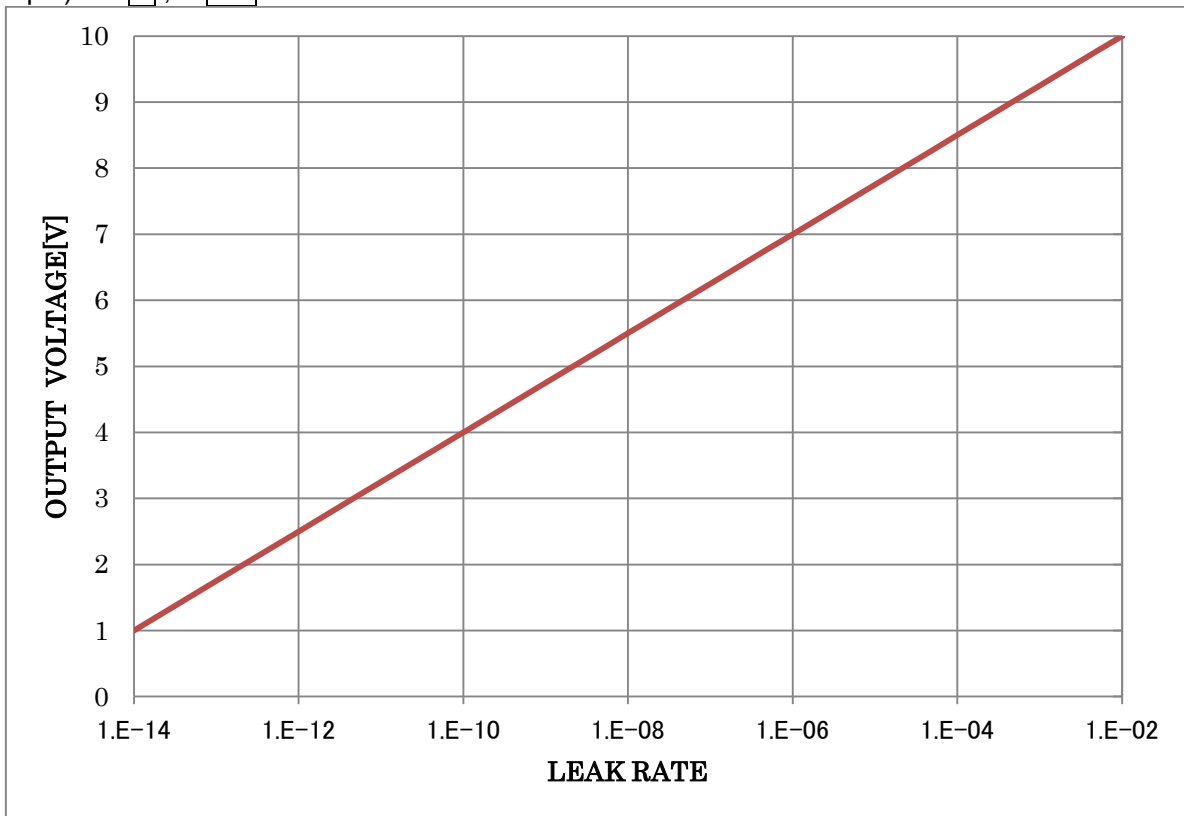

11-3 RS232C

Connection of either Printer or RS-232C communication connector is possible. If RS232C communication is employed, turn the printer setting (Section 5-3_4) to OFF.

11-3-1 Connection of Printer

The printer prints the startup sensitivity (minimum detection sensitivity) of each flow and measurement value (leak rate) for test. The recommended printer is listed below, however, connection of other printer is possible if the specifications are similar.



CAUTION

Printer

When a printer with different specifications is connected, it may lead to incorrect printing or cause malfunction.

(1) Recommended Printer

Seiko Instruments Inc.

•Thermal printer	DPU-414-41B
•AC adaptor	PW-4007-J1
•Input signal	8-bit serial
•Printing capacity	40 digits
•Character size	2.47×1.88 mm
•Normal paper	Paper width 112 mm: length of roll 28 m Type : TP-411L-1
•Clean room paper	Paper width 112 mm: length of roll 28 m Type : TP-469L

(2) Recommended Printer DIS SW Setting

Dip SW-1

1(OFF)	:INPUT	= Serial
2(ON)	:Printing Speed	= High
3(ON)	:Auto Loading	= ON
4(ON)	:AUTO LF	= ON
5(ON)	:Setting Command	= Enable
6(OFF)	:Printing	
7(ON)	:Density	
8(ON)	:	= 100 %

Dip SW-2

1(ON)	:Printing Columns	= 40
2(ON)	:User Font Back-up	= ON
3(ON)	:Character Select	= Normal
4(ON)	:Zero	= Normal
5(ON)	:International	
6(ON)	:Character	
7(ON)	:Set	
8(ON)	:	= Japan

Dip SW-3

1(ON)	:Data Length	= 8 bits
2(ON)	:Parity Setting	= No
3(ON)	:Parity Condition	= Odd
4(ON)	:Busy Control	=H/W Busy
5(OFF)	:Baud	
6(ON)	:Rate	
7(ON)	:Select	
8(ON)	:	=9600 bps

- (3) Connection of Printer
 Connect the printer to the main unit RS232C connector using D-Sub9Pin cross cable.

HELIOT side PIN No.		Wire connection	Printer PIN No.	
TxD	2		3	RxD
RxD	3		2	TxD
GND	5		5	GND

- (4) Print Setting of Printer
 On setting screen, set Printer (Section 5-3_4) to **ON**, Serial communication to **RS232C** and Baud Rate to **9600bps** (Section 5-3_3), the sensitivity of each flow at the time of startup completion are printed out. The test measurement value (leak rate) at the time of completion of the test is automatically printed out. By pressing **LEAK RATE DISPLAY** during test, the test measurement value of the time is printed out. If the Printer (Section 5-3_4) is set to **OFF**, the startup sensitivity data and automatic printing at the time of completion of the test will not be executed.

- (5) Printing

```

*****
* ULVAC, Inc.   DATE:20**/**/** **:** *
* Leak Detector HELIOT 900 *
*   ULTRA   : *.**E-** Pam3/s *
*   FINE    : *.**E-** Pam3/s *
*   GROSS   : *.**E-** Pam3/s *
*   SETPOINT1 : *.**E-** Pam3/s *
*   SETPOINT2 : *.**E-** Pam3/s *
*   SETPOINT3 : *.**E-** Pam3/s *
*****
No.  VALVE:LEAK  DATE/TIME
[Pam3/s]
00001 ULTRA: *.**E-** 20**/**/** **:**
00002 FINE : *.**E-** 20**/**/** **:**
00003 GROSS: *.**E-** 20**/**/** **:**
00004 SNIF : *.**E-** 20**/**/** **:**
    
```

- 1) Startup date/time
 Prints out the date and time of startup
- 2) Sensitivity of each flow
 Displays sensitivity of ULTRA, FINE and GROSS
- 3) Set point 1-3
 Displays setting value of each set point.
- 4) Measurement Result
 Displays test result (test measurement value). 00001 up to 99999 are in sequence. Prints out the date and the time of test flow and leak rate.
 The number is initialized when Startup and Sensitivity calibration are executed.
 Test valve display, leak rate, date and time at the time of measurement are printed.

11-3-2 RS-232C Communication

RS-232C communication is made possible by using cable (D-Sub9Pin) commercially available.



CAUTION

Connection of Connector

MAIN POWER must always be turned OFF before connecting the connector to the main unit. Risk of damage to the equipment.

11-3-2-1 Communication Protocol

Communication protocol : RS-232C
 Signal format : 2-wire system
 : half duplex
 Transfer architecture : Start stop synchronization
 Transfer speed : 9600,192000, 384000bps (changeable by setting)
 Transfer distance : 15m
 Max. number of connection: 1
 Bit configuration
 Start bit : 1bit
 Data bit : 8bit
 Parity bit : None
 Stop bit : 1bit
 Data configuration : All data are ASCII codes
 Data format
 Command : 3 bytes, fixed (command 2 bytes +CR)
 Response : R2(OK), R4(ERR), Data +CR

Example of RS232C connection is shown below. D-sub9 pin for the host.

HELIOT side PIN No.		Wire connection	Host side PIN No.	
TxD	2		2	TxD
RxD	3		3	RxD
GND	5		5	GND

11-3-2-2 Commands

Command	Parameter	Response	Data	Description
A1	-	OK	R2	Stops the equipment
		ERR	R4	During stop During error When startup setting accessory is installed
A2	-	OK	R2	Starts the equipment
		ERR	R4	Except stop When startup setting accessory is installed
A3	-	OK	R2	Starts testing
		ERR	R4	During standby Except during checking double vent
A4	-	OK	R2	Terminates testing
		ERR	R4	Except during testing
A5	-	OK	R2	Auto Zero ON/OFF
		ERR	R4	Except during testing
AG	-	OK	R2	Waiting for calibration leak
		ERR	R4	Except during standby
AB	-	OK	R2	Execute clean up
		ERR	R4	During startup During error
AC	-	OK	R2	Execute Peak hold monitoring
		ERR	R4	Except during testing
A6	-	OK	R2	Printing ON
		ERR	R4	Printing command period 3 sec or below
A7	-	OK	R2	Execute sensitivity recalibration
		ERR	R4	Except during stop and testing When startup setting accessory is installed
AE	-	OK	R2	Execute calibration
		ERR	R4	Except calibration request
A8	-	-	R2	Increase measurement range
A9	-	-	R2	Decrease measurement range
B0	-	-	R2	Release error
B2	-	-	**±**.*	Test mode, temperature read out Test mode code 2 digits, temperature 5 digits
B3	-	-	*****	Equipment state read out State code 2 digits, error code 4 digits (error catalog list)
B4	-	-	±n.nnE± nn***	Leak value read out Leak value 9 digits, 1 digit within zero, unit 1 digit, coefficient display (1=ON, 0=OFF)
B5	-	-	n.nnE±nn	Pirani pressure read out Pressure value 8 digits
BD	-	-	***	Sniffer flow rate read out Flow rate 3 digits

11. Input/Output Signals

Command	Parameter	Response	Data	Description
C1	-	-	*	Measured gas read out (0=He, 1=H2)
C1	*	OK	R2	Measured gas setting (0=He, 1=H2)
		ERR	R4	Setting error After completion of startup Command byte count is different
C0	-	-	*	Test mode read out
C0	*	OK	R2	Test mode setting
		ERR	R4	Except stop Setting error Command byte count is different
G1	-	-	*	Cycle test read out (1=OFF, 0=ON)
G1	*	OK	R2	Cycle test setting (1=OFF, 0=ON)
		ERR	R4	During startup During error Command byte count is different
G2	-	-	***.**,*	Roughing timer read out Timer setting 5 digits, Unit 1 digit (0=sec), Setting 1 digit (1=Time priority, 0=Constant Pressure)
G2	***.**,*	OK	R2	Roughing timer setting Timer setting 5 digits, Unit 1 digit (0=sec), Setting 1 digit (1=Time priority, 0= Constant Pressure)
		ERR	R4	During startup During error Command byte count is different
G9	-	-	***.**,*	Background timer read out Timer setting 5 digits, Unit 1 digit (0=sec), Setting 1 digit (0=BELOW SP.2, 1=Time priority, 2=SKIP)
G9	***.**,*	OK	R2	Background timer setting Timer setting 5 digits, Unit 1 digit (0=sec), Setting 1 digit (0=BELOW SP.2, 1=Time priority, 2=SKIP)
		ERR	R4	During startup During error Command byte count is different
G3	-	-	***.**,*	He Spray timer read out Time setting 5 digits, Unit 1digit (0=sec), Setting 1digit (2=Time priority, 1= =Test time)
G3	***.**,*	OK	R2	He Spray timer setting Time setting 5 digits, Unit 1digit (0=sec), Setting 1digit (2=Time priority, 1= =Test time)
		ERR	R4	During startup During error Command byte count is different
G4	-	-	***.**,*	Test timer read out Timer setting 5 digits, Unit 1 digit (0=sec), Setting 1 digit (1=Time priority, 0=Test end at ng)
G4	***.**,*	OK	R2	Test timer setting Timer setting 5 digits, Unit 1 digit (0=sec), Setting 1 digit (1=Time priority, 0=Test end at ng)
		ERR	R4	During startup During error Command byte count is different

11. Input/Output Signals

Command	Parameter	Response	Data	Description
C6	-	-	*	Auto zero read out (0=1SHOT, 1=ALTERNATE, 2=INVALID)
C6	*	OK	R2	Auto zero setting (0=1SHOT, 1=ALTERNATE, 2=INVALID)
		ERR	R4	Setting error Command byte count is different
D1	-	-	*	Vent control read out (0=AUTO, 1=MANUAL, 2=INVALID)
D1	*	OK	R2	Vent control setting (0=AUTO, 1=MANUAL, 2=INVALID)
		ERR	R4	During startup During error Command byte count is different
G5	-	-	***,*	Vent time setting read out Time setting 3 digits, setting 1 digit (0=NORMALLY OPEN, 1=Time setting)
G5	***,*	OK	R2	Vent time setting Time setting 3 digits, setting 1 digit (0=NORMALLY OPEN, 1=Time setting)
		ERR	R4	During startup During error Command byte count is different
C3	-	-	**	Read out during calibration startup (Except Sniffer (concentration) setting) (1 st digit 1=With calibration, 0=Without calibration 2 nd digits 0=INT. CAL. LEAK, 1= EXT. CAL. LEAK)
C3	**	OK	R2	Setting during calibration startup (Except Sniffer (concentration) setting) (1 st digit 1=With calibration, 0=Without calibration 2 nd digits 0=INT. CAL. LEAK, 1= EXT. CAL. LEAK)
		ERR	R4	Except when stop During error Command byte count is different
C3	-	-	**	Read out during calibration startup (Sniffer (concentration) setting) (1 st digit 1=With calibration, 0=Without calibration 2 nd digits 0=ATM, 1=STD GAS)
C3	**	OK	R2	Setting during calibration startup (Sniffer (concentration) setting) (1 st digit 1=With calibration, 0=Without calibration 2 nd digits 0=ATM, 1=STD GAS)
		ERR	R4	After completion of startup Command byte count is different
H1	-	-	*	Ion voltage adjustment read out (0=At start-up only, 1=At every cal.)
H1	*	OK	R2	Ion voltage adjustment setting (0=At start-up only, 1=At every cal.)
		ERR	R4	During startup During error Command byte count is different

11. Input/Output Signals

Command	Parameter	Response	Data	Description
EB	-	-	*	Calibration check read out (0= No, 1= Yes)
EB	*	OK	R2	Calibration check setting (0= No, 1= Yes)
		ERR	R4	During startup During error Command byte count is different
EC	-	-	** *,**	Calibration check read out Reference range 4 digits, checking frequency 2 digits
EC	** *,**	OK	R2	Calibration check setting Reference range 4 digits, checking frequency 2 digits
		ERR	R4	During startup During error Command byte count is different
D7	-	-	*	Test screen read out (0=Graph, 1=Meter, 2=Vac. diagram, 3=Value)
D7	*	OK	R2	Test screen setting (0=Graph, 1=Meter, 2=Vac. diagram, 3=Value)
		ERR	R4	During startup During error Command byte count is different
C2	-	-	*	Unit leak rate read out of
C2	*	OK	R2	Unit leak rate setting
		ERR	R4	During error Command byte count is different
CA	-	-	*	Unit pressure read out (0=Pa,1=mbar,2=atm,3=Torr)
CA	*	OK	R2	Unit pressure setting (0=Pa,1=mbar,2=atm,3=Torr)
		ERR	R4	Setting error Command byte count is different
E5	-	-	** **	Leak rate coefficient read out Setting value 5 digits
E5	** **	OK	R2	Leak rate coefficient setting Setting value 5 digits
		ERR	R4	Setting error Command byte count is different
CD	-	-	*	Leak rate filter read out (0=Fast, 1=Normal, 2=Slow)
CD	*	OK	R2	Leak rate filter setting (0= Fast, 1=Normal, 2=Slow)
		ERR	R4	Setting error Command byte count is different
D2	-	-	*	Message notice read out (1=INVALID, 2=VALID)
D2	*	OK	R2	Message notice setting (1=INVALID, 2=VALID)
		ERR	R4	During startup During error Command byte count is different

11. Input/Output Signals

Command	Parameter	Response	Data	Description
D4	-	-	*	Message maintenance read out (1=INVALID, 2=VALID)
D4	*	OK	R2	Message maintenance setting (1=INVALID, 2=VALID)
		ERR	R4	During startup During error Command byte count is different
C7	-	-	*	Control read out (0=Tablet, 1=EXT.I/O, 2=Serial comm.)
C7	*	OK	R2	Control setting (0=Tablet, 1=EXT.I/O, 2=Serial comm.)
		ERR	R4	Setting error Command byte count is different
H3	-	-	*	Compatibility read out (0=None, 1=710/700, 2=300, 3=ZERO)
H3	*	OK	R2	Compatibility setting (0=None, 1=710/700, 2=300, 3=ZERO)
		ERR	R4	Setting error Command byte count is different
E9	-	-	*	REC. OUT voltage read out (0=Linear, 1=Logarithm)
E9	*	OK	R2	REC. OUT voltage setting (0=Linear, 1=Logarithm)
		ERR	R4	During error Command byte count is different
B7	-	-	n.nnE±nn*	Set point 1 read out Setting value 8 digits, set point 1 ON/OFF (1=ON, 0=OFF)
B7	n.nnE±nn	OK	R2	Set point 1 setting Setting value 8 digits
		ERR	R4	Setting change on touch panel Command byte count is different
E1	-	-	*	Set point buzzer read out (0=OFF, 1=ON)
E1	*	OK	R2	Set point buzzer setting (0=OFF, 1=ON)
		ERR	R4	Setting error Command byte count is different
B8	-	-	n.nnE±nn*	Set point 2 read out Setting value 8 digits, set point 2 ON/OF (1=ON, 0=OFF)
B8	n.nnE±nn	OK	R2	Set point 2 setting Setting value 8 digits
		ERR	R4	Setting change on touch panel Command byte count is different
B9	-	-	n.nnE±nn*	Set point read out Setting value 8 digits, set point 3 ON/OF (1=ON, 0=OFF)
B9	n.nnE±nn	OK	R2	Set point 3 setting Setting value 8 digits
		ERR	R4	Setting change on touch panel Command byte count is different

11. Input/Output Signals

Command	Parameter	Response	Data	Description
F1	-	-	n.nnE±nn	Internal calibration leak value (vacuum method) read out Setting value 8 digits
F1	n.nnE±nn	OK	R2	Internal calibration leak value (vacuum method) setting Setting value 8 digits
		ERR	R4	After completion of startup Command byte count is different
F2	-	-	*	Internal calibration leak value (vacuum method) temp./ decay compensation read out (0=VALID, 1=INVALID)
F2	*	OK	R2	Internal calibration leak value (vacuum method) temp./ decay compensation setting (0=VALID, 1=INVALID)
		ERR	R4	After completion of startup Command byte count is different
F3	-	-	*****	Calibration date of Internal calibration leak value (vacuum method) read out Year 4 digits, month 2 digits, day 2 digits
F3	*****	OK	R2	Calibration date of Internal calibration leak value (vacuum method) setting Year 4 digits, month 2 digits, day 2 digits
		ERR	R4	After completion of startup Command byte count is different
F5	-	-	n.nnE±nn,*	External calibration leak value He (vacuum method) read out Setting value 8 digits, unit 1 digit
F5	n.nnE± nn,*	OK	R2	External calibration leak value He (vacuum method) setting Setting value 8 digits, unit 1 digit
		ERR	R4	After completion of external startup Command byte count is different
FD	-	-	n.nnE±nn,*	External calibration leak value H2 (vacuum method) read out Setting value 8 digits, unit 1 digit
FD	n.nnE± nn,*	OK	R2	External calibration leak value H2 (vacuum method) setting Setting value 8 digits, unit 1 digit
		ERR	R4	After completion of external startup Command byte count is different
F6	-	-	*	External calibration leak value (vacuum method) control read out (0=Auto, 1=Manual)
F6	*	OK	R2	External calibration leak value (vacuum method) control setting (0=Auto, 1=Manual)
		ERR	R4	After completion of startup Command byte count is different

Command	Parameter	Response	Data	Description
F9	-	-	n.nnE±nn,*	External calibration leak value (Sniffer method) read out Setting value 8 digits, unit 1 digit
F9	n.nnE±nn,*	OK	R2	External calibration leak value (Sniffer method) setting Setting value 8 digits, unit 1 digit
		ERR	R4	After completion of startup Command byte count is different
FC	-	-	n.nnE+nn	Sniffer method standard gas value read out Setting value 8 digits
FC	n.nnE+nn	OK	R2	Sniffer method standard gas value setting Setting value 8 digits
		ERR	R4	After completion of startup Command byte count is different

(*1) For test modes refer to the list below

(*2) For status codes see below. For error codes refer to Section 8-3.

11-3-2-3 Status Codes

Code	Description
51	Stop
52	Start-up at Auto mode
53	Start-up at Ultra flow
54	Start-up at Fine flow
55	Start-up at Gross flow
56	Start-up at Sniffer/A
57	Start-up at Sniffer/B
58	Standby at Auto mode
59	Standby at Ultra flow
60	Standby at Fine flow
61	Standby at Gross flow
62	Standby at Sniffer/A
63	Standby at Sniffer/B
64	Roughing at Auto mode
65	Roughing at Ultra flow
66	Roughing at Fine flow
67	Roughing at Gross flow
68	Testing at Gross flow (Auto)
69	Testing at Fine flow (Auto)
70	Testing at Ultra flow (Auto)
71	Testing at Gross flow
72	Testing at Fine flow
73	Testing at Ultra flow
74	Testing at Sniffer/A
75	Testing at Sniffer/B

Code	Description
76	Push "VENT"
77	Sensitivity checking
78	Roughing at cal. check
79	Cal. leak value checking
80	Settings
81	Information
84	Cal. leak value check waiting
06	Request Sniffer method calibration leak
07	Request Sniffer method reference gas
31	Clean up processing
34	Over range
38	RAM clear

11-3-2-4 Test Mode Codes

Code	Description
00	Auto mode
01	Ultra flow
02	Fine flow
03	Gross flow
07	Sniffer concentration: Atm
08	Sniffer flow rate
09	Sniffer concentration: Std. gas

11-3-2-5 Unit Codes

Code	Description
0	Pa · m ³ /s
1	mbar · L/s
2	atm · cc/s
3	Torr · l/s
4	lusec
5	sccm
6	Mol/s
7	ppm
8	% × R
9	oz/a
A	g/a
B	Amp.

11-3-3 RS-485 Communication

11-3-3-1 Communication Specification

Signal format : RS-485
 : 2-wire system
 : half duplex
 Rotation method : Start stop synchronization
 Data configuration : ASCII code
 Transmission distance : 500m
 Max. No. of connection : 32 (includes host)
 Transfer speed : 9600,19200,38400bps (changeable by setting)
 Bit configuration
 Start bit : 1bit
 Data bit : 8bit
 Parity bit : None
 Stop bit : 1bit

11-3-3-2 Connection Method of Wire

(1) RS-485 No Terminal Resistance (example)

As a wire connection of RS485, USB serial interface, USB-485 of NATIONAL EQUIPMENTS is used as an example to describe wire connection of RS485.

HELIOT side PIN No.		Wire connection	Host side PIN No.	
LINE +	4		4	RxD+
			8	TxD+
LINE -	1		5	RxD-
			9	TxD-
GND	5		1	GND

(2) RS-485 No Terminal Resistance (example)

As a wire connection of RS485, USB serial interface, USB-485 of NATIONAL EQUIPMENTS is used as an example to describe wire connection of RS485.

When there will be multiple connections of RS-485, the total length of connection cable becomes 15 m or over, or frequent case of communication errors occur, it is essential to install terminal resistance to the terminal equipment.

HELIOT side PIN No.		Wire connection	Host side PIN No.	
LINE +	4		4	RxD+
			8	TxD+
LINE -	1		5	RxD-
			9	TxD-
GND	5		1	GND
Terminal resistance	9			
LINE +	6			

11-3-3-3 Checksum

Checksum is used for checking data sent is received properly. The calculation of the checksum will be up to a letter Xor (the exclusive theory sum) before checksum from the address.

When calculating checksum manually, it is useful to use a standard “calculator” in WINDOWS. Select scientific for calculator type and calculate the checksum in hexadecimal.

11-3-3-4 Block Configuration Diagram

This equipment employs half duplex type, 2-channel communication. The typical block configuration diagram is shown below. The DATA+ and DATA- of each unit, and inter-wire of the same signal name are connected. Communication will not be possible if connected reversely.

RS-485 has 2 lines (DATA+ and DATA-) and both output 1 data signal with differential motion (balanced transmission). Therefore, has excellent noise resistance against common mode noise.

Half duplex means, sent data and received data exist on these 2 lines, thus when data is sent from 2 nodes at the same time, the receiving side will not be able to receive the data properly. Therefore, the following procedure is used for communication.

- 1) Node side (900) is at communication stage.
- 2) Host designates the address of node and sends the command.
- 3) The designated address of the node responds according to the command.

As such the state when both sent and received data do not exist at the same time is called half duplex.

(Full duplex: Both sending and receiving are possible at the same time)

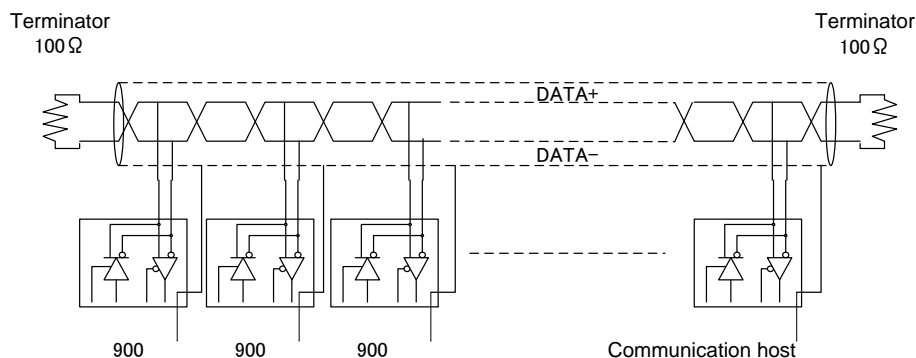

The transmission line that is ideal in terms of noise immunity is a twisted pair shielded wire, but theoretically a parallel 2-core wire can be used.

In addition, in order to repress returning wave and harmonize impedance, it is ideal to insert terminal resistance of 100 Ω at both ends of the channel path

11-3-3-5 Wiring Method

RS-485 enables multi-drop connection. (Multi-drop connects equipment (nodes) in sequence on 1 channel path)

The following diagrams show both proper and bad examples of connection. It operates in any short distances, however, caution is needed when wiring long distances.

When laying communication channel line on to a device, avoid access to or parallel wiring of, power lines, high voltage cables and high frequency cables. Risk of causing malfunction.

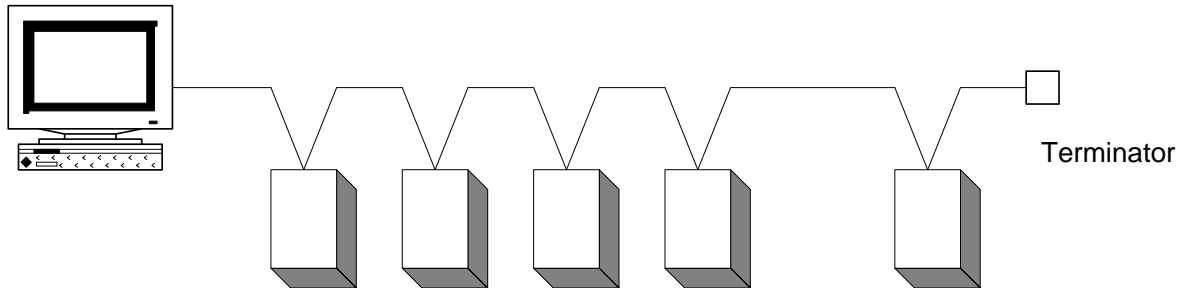

Correct connection

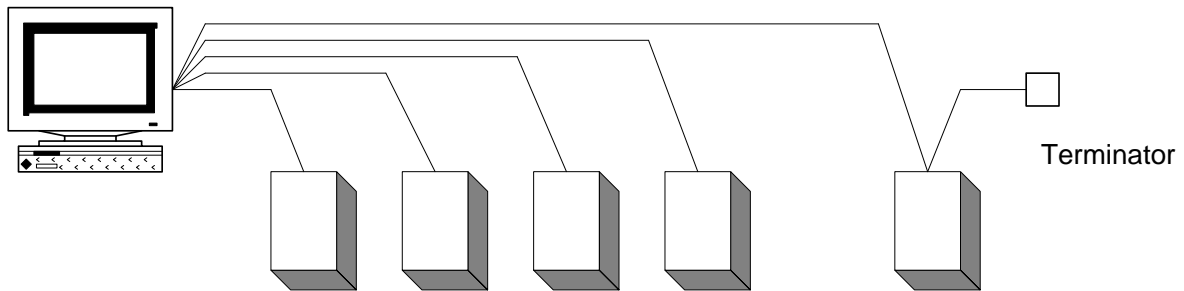

Incorrect connection -1

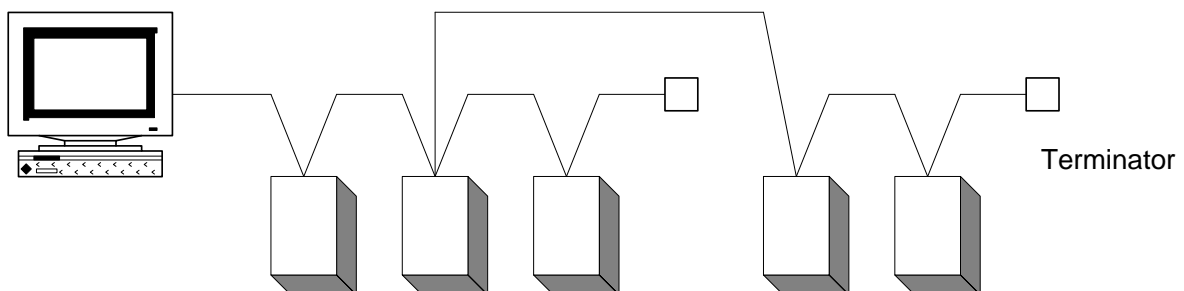

Incorrect connection -2

11-3-3-6 Basic Data Format

:	AD0	AD1	CMD	D0	Dn	CHKH	CHKL	CR
---	-----	-----	-----	----	-------	----	------	------	----

: : Colon
 AD0 : Equipment address/higher 4 bit (capital letters 0 – 9)
 AD1 : Equipment address/lower 4 bit (capital letters 0 – 9)
 CMD : Various commands (capital letters/caution to lower case letters)
 D0 : Data <4 bit> (capital letters: 0 – 9, A - F)
 Dn : Data <4 bit> (capital letters: 0 – 9, A - F)
 CHKH : Higher 4 bit of checksum (capital letters: 0 – 9, A - F)
 CHKL : Lower 4 bit of checksum (capital letters: 0 – 9, A - F)
 CR : Carriage return

- * The checksum will be the exclusive theory sum (XOR) of up to AD 0 – Dn. All ASCII codes must be converted in hexadecimal.
- * Routine of several tries of software is recommended.

11-3-3-7 List of Commands

Same commands as (Section 11-3-2-2) RS-232C.

11-3-3-8 Communication Time Chart

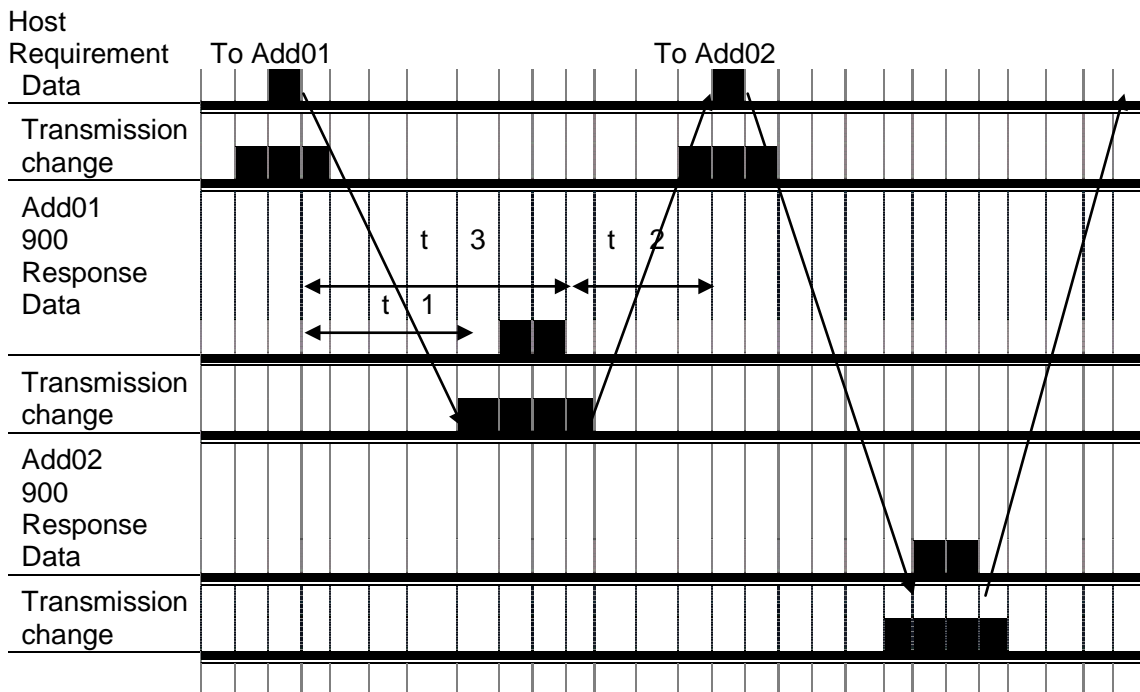

- To Add01 : Request of data from host to address No. 01 equipment
- Add01_900 Response : 900 of address No. 01 replies

- To Add02 : Request of data from host to address No. 02 equipment
- Add02_Tran Response : 900 of address No. 02 replies

Transmission change: 485 driver switches send and receive modes because of half duplex communication type. Some equipment may take long delay time to return to receive mode after sending data. (This equipment changes to receive mode after about 5ms)
 When data is sent while other equipment is maintaining send mode, 2 drivers on bus will turn to send modes and the data will not be received properly.
 In order to avoid such situation, when the equipment receives "CR" data sent by the host, starts sending data only after keeping an interval of approximately 20ms(t1) and more.
 Therefore, the host release the bus approximately within 20ms(t1) after sending the data. (It needs to be changed to a receive mode)
 Depending on the measurement control state at that time, the 900 may delay the response. The host must have the receiving time out (t3) to be 100ms or more from the time host sends the data to receive the response data of "CR"

















900 with other address are also receiving their own sent data.
 Non-related data are deleted from received memories after receiving data.
 The 900 cannot receive data properly, if the host side makes any request during this operation.
 Therefore, after receiving sent data of "CR" from 900, the next data must be requested with an interval of 20ms(t2).

11-3-3-9 List of ASCII Codes

				B7	0	0	0	0	1	1	1	1
				B6	0	0	1	1	0	0	1	1
				B5	0	1	0	1	0	1	0	1
B4	B3	B2	B1		0	1	2	3	4	5	6	7
0	0	0	0	0	NUL	TC7(DLE)	(SP)	0	@	P	`	p
0	0	0	1	1	TC1(SOH)	DC1	!	1	A	Q	a	q
0	0	1	0	2	TC2(STX)	DC2	"	2	B	R	b	r
0	0	1	1	3	TC3(ETX)	DC3	#	3	C	S	c	s
0	1	0	0	4	TC4(EOT)	DC4	\$	4	D	T	d	t
0	1	0	1	5	TC5(ENQ)	TC8(NAK)	%	5	E	U	e	u
0	1	1	0	6	TC6(ACK)	TC9(SYN)	&	6	F	V	f	v
0	1	1	1	7	BEL	TC10(ETB)	'	7	G	W	g	w
1	0	0	0	8	FE0(BS)	CAN	(8	H	X	h	x
1	0	0	1	9	FE1(HT)	EM)	9	I	Y	i	y
1	0	1	0	A	FE2(LF)	SUB	*	:	J	Z	j	z
1	0	1	1	B	FE3(VT)	ESC	+	;	K	[k	{
1	1	0	0	C	FE4(FF)	IS4(FS)	,	<	L	\	l	
1	1	0	1	D	FE5(CR)	IS3(GS)	-	=	M]	m	}
1	1	1	0	E	SO	IS2(RS)	.	>	N	^	n	~
1	1	1	1	F	SI	IS1(US)	/	?	O	_	o	(del)

11-4 Micro SD Card

Measurement data is stored in micro SD card within the tablet.
The file configuration inside the micro SD card will be as follows.
Never add or change the contents of the folder.

<ul style="list-style-type: none">  cache  Error  GaugeLog  LOST.DIR  Startup 	<p>Micro SD file is composed of several folders. Measurement data is stored inside the GaugeLog. Never add or change the contents of the folder.</p>
<ul style="list-style-type: none">  00000  12345 	<p>In the GaugeLog a serial folder of the equipment will be created. Select folder of connection equipment.</p>
<ul style="list-style-type: none">  20140515_0000  20140515_0001  20140515_0002  20140515_0003  20140515_0004  20140515_0005  20140515_0006  20140515_0007  20140515_0008 	<p>As for measurement data file, from the start till the end of the test composes a file and the file is created with sequence date number_0000. The data to be stored will record [DateTime], [LeakRate], [InnerPirani].</p>

【Example of record】

[DateTime]	[LeakRate]	[InnerPirani]
15:11:16	1.80E-14	7.30E-17
15:11:16	2.70E-14	6.80E-16
15:11:16	5.40E-14	3.60E-13
15:11:17	6.80E-14	7.70E-12
15:11:17	8.80E-14	8.20E-10
15:11:17	1.08E-13	8.70E-08
15:11:17	1.28E-13	9.20E-06
15:11:17	1.49E-13	9.70E-04
15:11:18	1.69E-13	2.00E-02
15:11:18	1.89E-13	7.00E+00
15:11:18	2.10E-13	1.20E+03
15:11:18	2.30E-13	1.70E+05
15:11:18	2.53E-13	5.30E+07
15:11:19	2.70E-13	2.60E-17
15:11:19	2.91E-13	3.10E-15
15:11:19	3.11E-13	3.60E-13

12. Guarantee

This instrument has been shipped from our facilities after rigorous in-house testing. Should any malfunction or trouble occur due to defective parts, or should the unit be damaged due to an accident or mishap during transit, please contact ULVAC or any ULVAC authorized agent. ULVAC guarantees the instrument against any defect in performance or manufacturing for 1 year from the time of delivery.

Any malfunctions or troubles occurring as a result of defects in the design or fabrication of the instrument within the warranty period will be serviced by ULVAC free of charge. However, for service carried out at a location other than the original location of delivery because the instrument was moved either within Japan or overseas, there may be instances when ULVAC will be compensated for various costs such as transportation or the dispatch of personnel. Please be aware that any malfunction or trouble caused by the operation of the instrument in a manner contrary to the instructions listed in the operations manual, malfunction caused by careless handling (for example, damage to the turbo molecular pump as a result of having suddenly injected air into the unit while testing was in progress), by having reconfigured or remodeled the unit without prior approval by ULVAC, by accidents caused by natural disasters and acts of God, or by consumable parts, are not guaranteed under this warranty.

[List of consumable parts] (the items below are not covered under warranty)

- 1) O-rings and gaskets
- 2) Hoses and tubes
- 3) Ion source (type: IS-BA1)
- 4) Pirani vacuum gauge head (type: WP-01)
- 5) Turbomolecular pump oil reservoir
- 6) Rotary pump oil (oil for 901W1: model R-2, oil for 904W2: model SMR-100)
- 7) Oil mist filter for 901W1
- 8) Built in lithium-ion battery for tablet
- 9) Vent filter
- 10) Air-cooling fan and air-cooling fan filter
- 11) Sniffer probe Metal tip element sintered: for sniffer AS/BS unit
- 12) Microseparator (type: MS-80): for Sniffer unit BS9/BT9
- 13) Diaphragm pump: For Sniffer unit BS9/BT9*1
- 14) Dust filter: For Sniffer unit BS9
- 15) Dust filter: For Sniffer unit BT9

(*1) Guaranteed up to 10000hrs of operating time if within 1 year of shipment from ULVAC Inc.

[About calibration leak value variations]

The output of the calibration leak, which is the sensitivity calibration standard, undergoes temperature compensation by the internal temperature sensor according to the customer's settings. For calibration leak output value attenuation as well, it also undergoes time compensation according to the amount of time elapsed from the calibration date. However, in order to maintain an even more accurate measurement environment, prepare a calibration leak managed separately by yourself. Measuring the managed calibration leak and checking if the appropriate indicated value is obtained is recommended.

If recalibration of the calibration leak is requested, your nearest service center will perform recalibration for a charge at the same time as a scheduled overhaul by bringing the unit back to the factory, or by bringing in only the calibration leak. A calibration certificate can also be issued for a fee by request.

[About purchasing repair parts and consumables]

Please contact the nearest service center for the purchase of repair parts and consumables.

Request Form for Repair/Inspection of ULVAC Components /Certificate of Contamination

This is a request form for repair/inspection of ULVAC components/certificate of contamination. Please enter the operating condition/trouble symptom of your vacuum gauge in this form and submit it to your local ULVAC service station or sales office after signing it. Regarding vacuum gauges used for pumping toxic gas or gauges contaminated with substances produced by reaction, please consult with your local ULVAC service station or sales office before filling in this form.

To ULVAC, Inc.

Date: _____

Person in charge you contacted: _____

Model name : _____

Model number : _____

Serial No. : _____

Application : _____

Repair/inspection requested _____

Trouble symptom _____

Note _____

Contaminant (Check an applicable box.)

 I guarantee that this vacuum gauge is not contaminated with harmful substances. This vacuum gauge is contaminated with the following harmful substances.

	Name of contaminant (molecular formula)	Characteristics
1		
2		
3		
4		
5		

Person in charge _____

Division _____

Name of company _____

Phone _____

Fax _____

E-mail _____

Please pack the product carefully before shipment because the shipper (user) is liable for damage that may be caused by contaminant in transit to ULVAC. It is also to be understood that ULVAC may decline to repair the product depending on the type of contaminant and degree of contamination and return it to the user.

To be filled in by ULVAC	Received by	
Request for MSDS: Yes/No		
ULVAC job No.		



EC DECLARATION OF CONFORMITY



We hereby declare that the following our products conform the essential health and safety requirement of the following directives and standards.

Product LEAK DETECTOR

Model HELIOT 901W1/901D2
 HELIOT 904W2/904D3/904D4
 With sniffer A-unit or B-unit

Manufacturer ULVAC, Inc.
 2500 HAGISONO, CHIGASAKI-SHI,
 KANAGAWA-KEN, 253-8543 JAPAN

Test standard Declared for the EU directive
 LDV: 2014/35/EU
 EMC: 2004/108/EC

to which this declaration relates, is in conformity with the following harmonized standards and/or other normative documents,

EU Harmonised Standards
LVD: EN 61010-1: 2010
EMC: EMS EN 61326-1:2013
 EMI CISPR 11:2009 +A1:2010 Group 1 Class A

(title and/or number and date at issue of the harmonized standards, and/or other normative documents)

Test lab. LDV: KT LAB CORPORATION
 EMC: RF Technologies Ltd.

Note: This declaration becomes invalid if technical or operational modifications are introduced without the manufacture's consent.

Signature : 

Date : 18/JUN/2014

Name : KIYOKAZU YANAGISAWA

Title : General Manager of Components Division

ULVAC

株式会社アルバック
<http://www.ulvac.co.jp/>

サービス拠点一覧
<http://www.ulvac.co.jp/support/service/index.html>

販売拠点一覧
http://www.ulvac.co.jp/support/sales_office/index.html



ulvac.co.jp

株式会社アルバック
規格品事業部
神奈川県茅ヶ崎市萩園 2 5 0 0
TEL:0467-89-2181

アルバック販売株式会社
本社（東京）
東京都中央区八重洲 2-3-1
TEL:03-5218-6011

アルバック販売株式会社
大阪支店
大阪府大阪市淀川区宮原 3-3-3 1
TEL:06-6397-2286

ULVAC ,Inc.
<http://www.ulvac.co.jp/eng/>
ULVAC VACUUM
<http://www.ulvac-vacuum.com/>

Service Centers
<http://www.ulvac.co.jp/eng/support/service/index.html>

Sales Offices
http://www.ulvac.co.jp/eng/support/sales_office/index.html



ulvac.co.jp(eng)

ULVAC, Inc.
Components Division
2500 Hagisono, Chigasaki, Kanagawa, Japan
TEL:+81-467-89-2181