



Technology for Vacuum Systems

Instructions for use



RE 2
RZ 2
RE 5
RZ 5
RE 8
RZ 8
RE 16
RZ 16

Rotary vane pumps

Dear customer,

Your VACUUBRAND rotary vane pump should support you for a long time without trouble and with maximal power. Thanks to our long practical experience we have much information how you could ensure powerful application and personal safety. Please read these instructions for use before the initial operation of your pump.

VACUUBRAND rotary vane pumps are the result of many years of experience in construction and practical operation of these pumps combined with the latest developments in material and manufacturing technology.

Our quality maxim is the "zero fault principle":

Every rotary vane pump leaving our company is tested intensively including an endurance run of 60 hours. Therefore also faults which occur rarely are identified and can be eliminated immediately.

The achievement of the specifications after the endurance run is tested for every pump.

Every VACUUBRAND pump achieves the specifications. We feel obliged to this high quality standard.

We know that the vacuum pump can not take a part of your real work and hope that our products contribute to an effective and trouble-free realisation of your work.

Yours

VACUUBRAND GMBH + CO KG

After sales service: Contact your local dealer or call (+49) 9342/808-193.



Attention! Important notes!



Not permitted! Misuse may cause damage.



Caution! Hot surface!



Isolate equipment from mains.



Note.

Contents

Safety information! 4

Technical data 7

Use and operation 11

Oil change 13

Troubleshooting 15

Notes on return to the factory 17

Health and safety clearance form 18

Supplementary information concerning the instructions for use 99 90 77 / rotary vane pumps

Rotary vane pumps VACUUBRAND RE 2 / RE 5 / RZ 2 / RZ 5 in latest design are equipped with new motors (see figure). The following modifications have to be considered:

Technical Data

Type		RE 2	RE 5	RZ 2	RZ 5
Motor power single phase	kW	0.18	0.3	0.18	0.3
Current draw* at operation					
230 V~ 50/60 Hz	A	1.6 / 1.5	2.5 / 2.4	1.6 / 1.5	2.5 / 2.4
120 V~ 60 Hz	A	3.0	4.6	3.0	4.6
Max. permitted range of supply voltage		120 V ~ +5%/-10% 60 Hz 230 V~ +/-10% 50/60 Hz			
Motor protection		thermal cutout			

* When the pump is starting, for a short period the current draw might be two or three times as much as during operation.

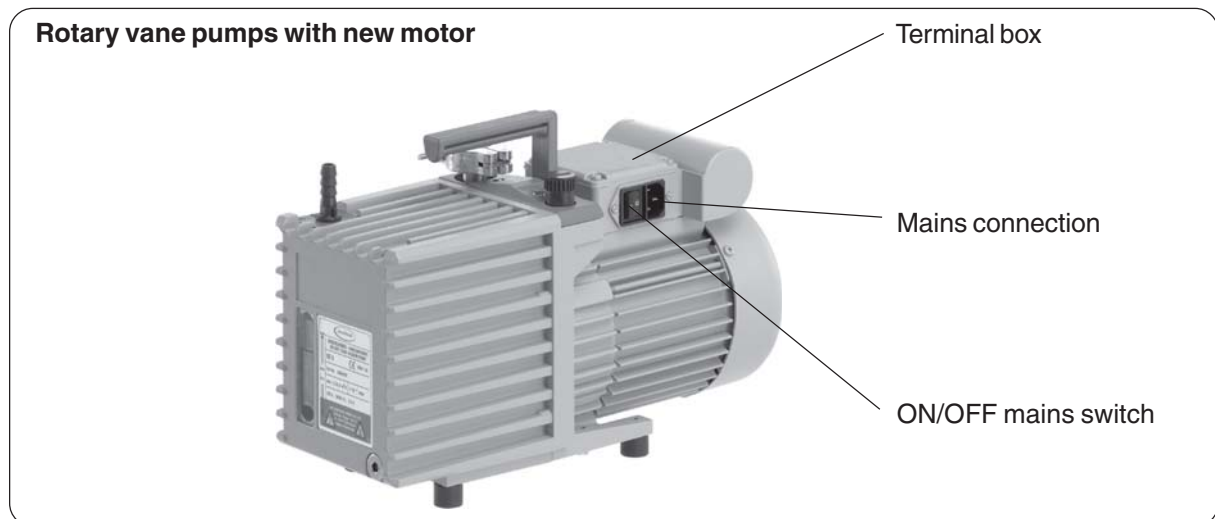

We reserve the right for technical modification without prior notice!

Safety information!



Remove all packing material, remove the product from its packing-box, remove the protective covers from the inlet and outlet ports and keep them, inspect the equipment and check oil level.

- ☞ If the pump is delivered without oil filling, fill in oil (see section "oil change").
- If the equipment is damaged, notify the supplier and the carrier in writing within three days; state the item number of the product together with the order number and the supplier's invoice number. Retain all packing material for inspection.

Do not use the equipment if it is damaged.

If the equipment is not used immediately, replace the protective covers. Store the equipment in suitable conditions.

- ☞ If the pump is delivered without oil filling, fill in oil, see section "Oil change".
- ☞ Carry out the first oil change after 100 hours operation time.
- ☞ **Read and obey this manual before installing or operating the equipment.**
- ☞ Transport the pump at the provided handles.



Use the equipment for the intended use only (for generation of vacuum).

- ☞ **Prevent any part of the human body from coming into contact with the vacuum.**

Comply with **national safety regulations and safety requirements** concerning the use of vacuum and electrical equipment.

- ☞ Equipment must be connected only to a suitably fused and protected electrical supply and a suitable earth point. Failure to connect the motor to ground may result in deadly electrical shock.
- ☞ The supply cable may be fitted with a moulded European IEC plug or a plug suitable for your local electrical supply. If the plug has been removed or has to be removed, the cable will contain wires colour coded as follows: green or green and yellow: earth; blue or white: neutral; brown or black: live.
- ☞ Check that mains voltage and current conform with the equipment (see rating plate).
- ☞ Ensure that the pump motor rotates in the correct direction. If it does not, the pump and the vacuum system become pressurised, the system may burst.
- ☞ If the equipment is brought from cold environment into a room for operation, allow the equipment to warm up (pay attention to water condensation on cold surfaces).
- ☞ Make sure ventilation is adequate if pump is installed in a housing or if ambient temperature is elevated.



Comply with all **relevant safety requirements** (regulations and guidelines) and adopt suitable safety measures.

- ☞ Provide a firm level platform for the equipment and check that the system to be evacuated is mechanically stable and that all fittings are secure. Attention: Flexible elements tend to shrink when evacuated.

Due to the high compression ratio of the pumps, generated pressure at the outlet port might be higher than the max. permitted pressure compatible with the mechanical stability of the system.

- ☞ Comply with maximum permitted pressures and pressure differences.



Do not permit any **uncontrolled pressurizing** (e. g. make sure that the exhaust pipeline cannot become blocked). If you have an exhaust-isolation valve, make sure that you cannot operate the equipment with the valve closed. **Risk of bursting!**

- ☞ Ensure that the system design does not allow the exhaust pipeline to become blocked.
- ☞ Avoid overpressure of more than 0.2 bar in case inert gas is connected.
- ☞ The diameter of the inlet and outlet pipeline should be at the least as large as the diameter of the pump connection pipelines.



To the best of our knowledge the equipment is in compliance with the requirements of the applicable EC-directives and harmonized standards with regard to design, type and model, especially directive IEC 1010. This directive gives in detail conditions, under which the equipment can be operated safely.

- ☞ Adopt suitable measures in case of different conditions, e. g. using the equipment outdoors, installation in altitudes of more than 1000 m above mean sea level, conductive pollution or dewiness.



Pay attention to symbol “hot surfaces“ on the equipment (according to IEC 1010 recommendation).

- ☞ Adopt suitable measures to prevent any danger arising from the formation of hot surfaces or electric sparks.



The pumps have no approval for operation in or for pumping of potentially explosive atmospheres.

If pumping **different substances**, purge the pump with inert gas prior to changing the pumped media in order to pump out residues and to avoid reactions of the pumped substances with each other with and the pump material.

Take into consideration interactions and chemical reactions of the pumped media.

The pumps are **not suitable** for pumping substances which may form **deposits** inside the pump.

- ☞ If there is a danger of the formation of **deposits** in the pump chamber (check inlet and outlet of the pump) inspect the pump chamber regularly and clean if necessary. The pumps are **not suitable** to pump **unstable substances** and substances which react explosively under **impact** (mechanical stress) and/or when being exposed to **elevated temperatures** without air.

The pumps are **not suitable** to pump **self inflammable** substances, substances which are inflammable without air and **explosive substances**.

The pumps are **not suitable** for pumping dust and have **no approval** for operation below ground.

- ☞ Adopt suitable measures to prevent the release of dangerous, explosive, corrosive or polluting fluids.
- ☞ Use a cold trap if aggressive or corrosive media are pumped.
- ☞ Use inert gas for gas ballast if necessary.
- ☞ The user must take suitable precautions to prevent any formation of explosive mixtures in the expansion chamber.
- ☞ Take adequate precautions to protect people from the effects of dangerous substances (chemicals, oil mist, thermal decomposition products of fluoroelastomers), wear appropriate safety-clothing and safety glasses.
- ☞ Comply with applicable regulations when disposing of chemicals. Take into consideration that chemicals may be polluted.



The **single-phase motor** is shut down by a **thermal cutout** in the winding.

- ☞ **RE 2 (120/230 V) / RZ 2 (120/230 V) / RE 5 (120/230 V) / RZ 5 (120/239 V) / RE 8 (230 V):** Manual reset is necessary. Switch off the pump or isolate the equipment from mains. Wait approx. five minutes before restarting the pump.

- ☞ **RZ 8 (120 V) / RE 16 (120/230 V) / RZ 16 (120/230 V): Attention:** The pump has an automatic reset and will start after sufficient cooling down. Take suitable precautions if a restart can be dangerous. To prevent automatic restart of the pump motor, connect the pump to the electrical supply through suitable control equipment which must be reset manually.



The **three-phase motor** is equipped with a **circuit-breaker** which isolates all poles in the event of an overload.

- ☞ Manual reset is necessary. Switch off the pump or isolate the equipment from mains. Wait approx. five minutes before restarting the pump.
- ☞ Avoid high heat supply (e. g. due to hot process gases)
- ☞ Ensure sufficient air admittance if pump is installed in a housing.

Ensure that in case of failure, the pump and the vacuum system turn always into a safe status.

- ☞ In case of leaks in the manifold or at the shaft seal pumped substances may leak into the environment or in the pump housing or the motor.
- ☞ Comply especially with all notes on use and operation and on maintenance.
- ☞ Failure of the pump (e. g. due to power failure) connected components or parts of the supply or change of parameters must not lead to a critical dangerous situation under any circumstances.



Use only oil of the recommended type.

- ☞ Other oils or operating fluids may cause damage of the pump or danger.
- Use **special oils** (e. g. perfluoropolyether oils) if:
- ☞ The pump operates in the vicinity of potential ignition sources.
 - ☞ Oxygen or other flammable gases account for a large proportion of the evacuated gases.

Adopt precautionary measures (e. g. wear appropriate safety-clothing and protective goggles) to avoid excessive contact with the skin and possible skin irritations (including dermatitis).

- ☞ Observe all relevant statutory requirements and regulations concerning the use, storage and disposal of oil.

Use only **genuine spare parts and accessories**.

- ☞ Otherwise safety and performance of the equipment as well as the electromagnetic compatibility of the equipment might be reduced.

Wear parts have to be replaced regularly. Bearings have a typical durability of 40000 h. Motor capacitors have a typical durability in the range of 10000 to 40000 h depending strongly on the operation conditions like ambient temperature, humidity or load.

- ☞ Check every capacitor regularly by measuring its capacity and estimating its operation time. Exchange old capacitors early enough to prevent a failure. If an overaged motor capacitor fails it might get hot and even melt and may cause a flame to form which could be **dangerous for persons and equipment in the vicinity**. The capacitors have to be replaced by an electrician.

Ensure that maintenance is done only by suitably trained and supervised technicians. Ensure that the maintenance technician is familiar with the safety procedures which relate to the product processed by the vacuum system and that the equipment, if necessary, is appropriately decontaminated before starting maintenance.

Obey local and national safety regulations.

Before starting maintenance, vent the system, isolate the pump and other components from the vacuum system and the electrical supply, drain condensate and allow sufficient cooling of the pump.



In order to comply with law (occupational, health and safety regulations, safety at work law and regulations for environmental protection) vacuum pumps, components and measuring instruments returned to the manufacturer can be repaired only when certain procedures (see section “**Notes on return to the factory**”) are followed.

Technical data

Gas inlet temperatures:

Operating condition	Inlet pressure	Permitted range of gas temperatures at inlet
Continuous operation	> 100 mbar (high gas load)	➡ +10°C to +40°C
Continuous operation	< 100 mbar (low gas load)	➡ 0°C to +60°C
Short-time operation (< 5 minutes)	< 100 mbar (low gas load)	➡ -10°C to +80°C

Type		RE 2	RE 5	RZ 2	RZ 5
Pumping speed 50/60 Hz	m ³ /h	2.2/2.5	5.6/6.4	2.2/2.5	5.6/6.4
Ultimate partial vacuum without gas ballast	mbar	3 x 10 ⁻¹	1 x 10 ⁻¹	4 x 10 ⁻⁴	4 x 10 ⁻⁴
Ultimate total vacuum without gas ballast	mbar	3 x 10 ⁻¹	1 x 10 ⁻¹	5 x 10 ⁻³	2 x 10 ⁻³
Ultimate total vacuum with gas ballast	mbar	8 x 10 ⁻¹	6 x 10 ⁻¹	1 x 10 ⁻²	1 x 10 ⁻²
Water vapour tolerance	mbar	40	40	40	40
Oil capacity Min./Max.	ml	180/530	370/950	140/300	350/750
Recommended oil		VACUUBRAND B-oil			
Permitted ambient temperature during storage/operation	°C	-10 to +60 / +12 to +40			
Permitted relative atmospheric moisture during operation (no condensation)	%	30 to 85			
Motor power single phase	kW	0.18	0.3	0.16	0.3
Motor power three phase	kW	-	0.25	-	0.25
Max. operating current*					
120 V~ 60 Hz	A	3.1	4.5	2.4	4.5
230 V~ 50/60 Hz	A	1.8/1.5	2.2/2.2	1.7/1.2	2.2/2.2
400 V 3~** 50 Hz	A	-	0.8	-	0.8
Power draw					
120 V~ 60 Hz	kW	0.36	0.54	0.29	0.54
230 V~ 50/60 Hz	kW	0.41/0.345	0.5/0.5	0.39/0.28	0.5/0.5
400 V 3~** 50 Hz	kW	-	0.55	-	0.55
Max. permitted range of supply voltage		+5%/-10% 60 Hz (RE 2: 110-115 V)			
120 V~		+/-10% 50/60 Hz			
230 V~		+/-10% 50 Hz			
400 V 3~**					
Rated speed 50/60 Hz	min ⁻¹	1500/1800			
Motor protection single phase		thermal			
Motor protection three phase		isolates all poles in the event of an overload			
Degree of protection IEC 529		IP 40			
Measuring surface sound pressure level (enveloping surface method; distance 1m)	dBA	48	52	47	49
Inlet/outlet		small flange NW 16/hose nozzle NW 10			
Mass, fully operational	kg	9.8	15.3	11.8	16.5

* When the pump is starting, for a short period the power draw might be two or three times as much as during operation.

** Ensure that the pump motor rotates in the correct direction.

We reserve the right for technical modification without prior notice!

Type		RE 8	RE 16	RZ 8	RZ 16
Pumping speed 50/60 Hz	m ³ /h	8.6/9.9	16.6/19.1 (maximum)	8.6/9.9	16.6/19.1 (maximum)
Ultimate partial vacuum without gas ballast	mbar	1 x 10 ⁻¹	1 x 10 ⁻¹	4 x 10 ⁻⁴	4 x 10 ⁻⁴
Ultimate total vacuum without gas ballast	mbar	1 x 10 ⁻¹	1 x 10 ⁻¹	2 x 10 ⁻³	2 x 10 ⁻³
Ultimate total vacuum with gas ballast	mbar	6 x 10 ⁻¹	6 x 10 ⁻¹	1 x 10 ⁻²	1 x 10 ⁻²
Water vapour tolerance	mbar	40	40	40	40
Oil capacity Min./Max.	ml	400/1400	300/1000	200/800	500/1000
Recommend oil		VACUUBRAND B-oil			
Permitted ambient temperature during storage/operation	°C	-10 to +60 / +12 to +40			
Permitted relative atmospheric moisture during operation (no condensation)	%	30 to 85			
Motor power single phase	kW	0.37	0-55	0.37	0.55
three phase	kW	0.37	0.55	0.37	0.55
Max. operation current*					
120 V~ 60 Hz	A	5.2	6.9	6.9	6.9
230 V~ 50/60 Hz	A	3.0/2.6	4.5/3.7	4.5/3.7	4.5/3.7
400 V 3~** 50 Hz	A	1.1	1.4	1.1	1.4
Power draw					
120 V~ 60 Hz	kW	0.62	0.83	0.83	0.83
230 V~ 50/60 Hz	kW	0.69/0.6	1.035/0.85	1.035/0.85	1.035/0.85
400 V 3~** 50 Hz	kW	0.55	0.97	0.97	0.97
Max. permitted range of supply voltage					
120 V~		+5%/-10% 60 Hz			
230 V~		+/-10% 50/60 Hz			
400 V 3~**		+/-10% 50 Hz			
Rated speed 50/60 Hz	min ⁻¹	1500/1800			
Motor protection single phase three phase		thermal isolates all poles in the event of an overload			
Degree of protection IEC 529		IP 40			
Measuring surface sound pressure level (enveloping surface method, distance 1m)	dBA	53	55	52	55
Inlet/outlet		small flange NW 25			
Mass, fully operational	kg	23.0	24.5	25.5	28.0

* When the pump is starting, for a short period the power draw might be two or three times as much as during operation.

** Ensure that the pump motor rotates in the correct direction.

We reserve the right for technical modification without prior notice!

RE 2 / RZ 2

(fig. RZ 2, pump RE 2 with different terminal box)

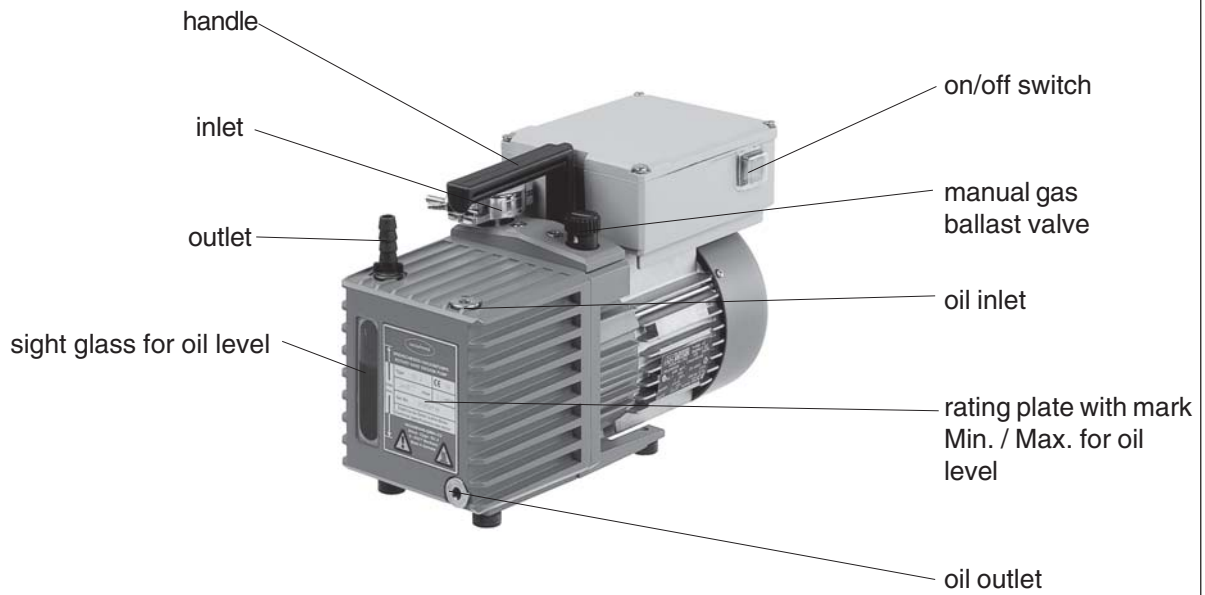

RE 5 / RZ 5

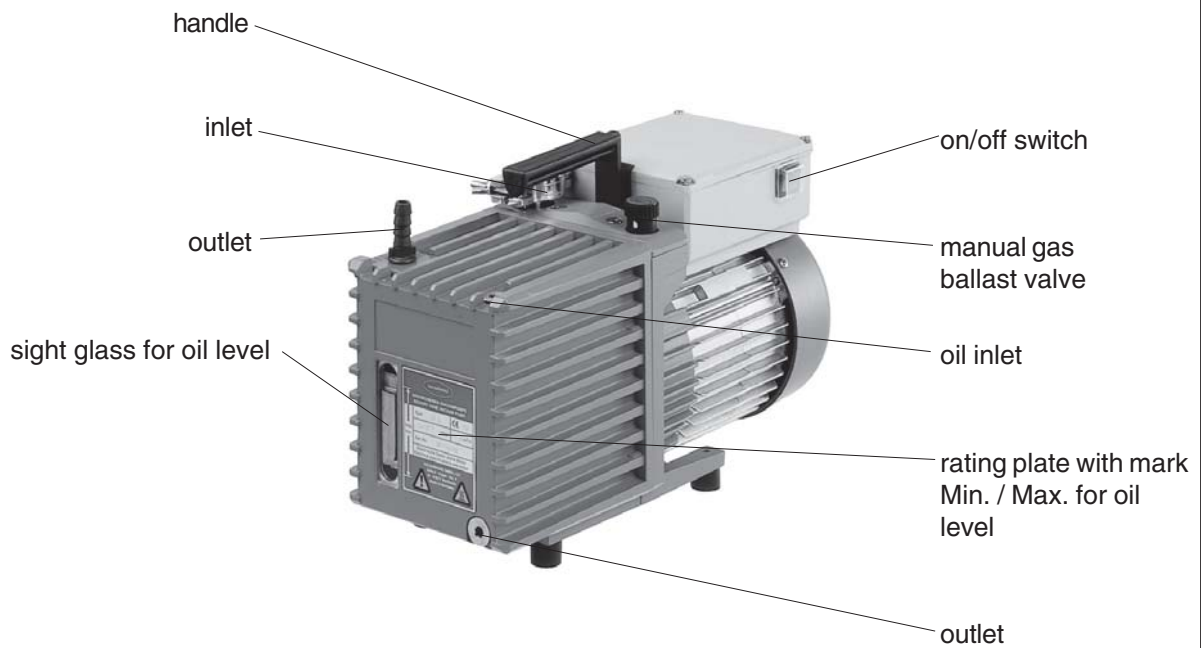

RE 8 / RZ 8

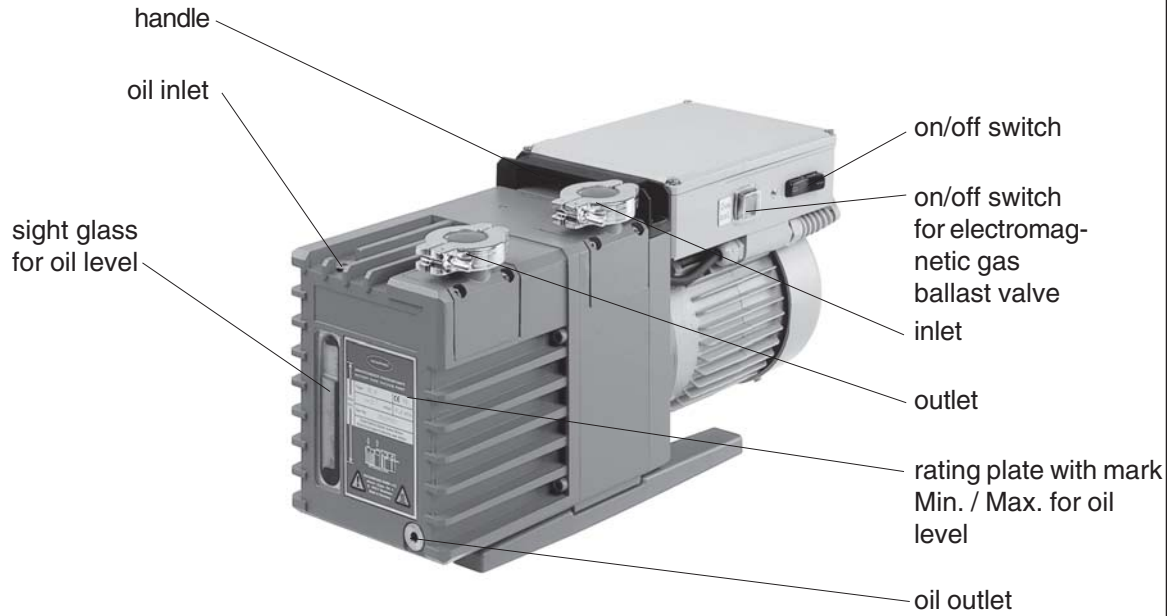

RE 16 / RZ 16



Use and operation



Installing in a vacuum system:

- ☞ Avoid throttling losses by using connecting pipes with large diameter and keeping them as short as possible.
- ☞ Reduce the transmission of vibration and prevent loading due to rigid pipelines. Insert elastic hoses or flexible elements as couplings between the pump and rigid pipes. **Attention:** Flexible elements tend to shrink if evacuated.
- ☞ Use a suitable valve to isolate the pump from the vacuum system if you need to allow the pump to warm up before you pump condensable vapours or if you clean the pump before it is switched off.
- ☞ Connect the exhaust to a suitable treatment plant to prevent the discharge of dangerous gases and vapours to the surrounding atmosphere. Use a catchpot to prevent the drainage of contaminated condensate back into the pump.



Prior to use:

- ☞ **Max. ambient temperature:** 40 °C.
- ☞ Ambient temperature should be at least 12 °C, because otherwise the pump possibly does not start because of the high oil viscosity at low temperature.
- ☞ Check oil level of the rotary vane pump every time before starting the pump, however at least one a week. Check oil level more frequently if high gas or vapour quantities are pumped.
- ☞ Make sure ventilation is adequate if pump is installed in a housing or if ambient temperature is elevated. Keep a distance of min. 20 cm between fans and ambient parts.
- ☞ If pump is installed in altitudes of more than 1000 m above mean sea level check compatibility with applicable safety requirements, e. g. DIN VDE 0530 (motor may overheat due to insufficient cooling).
- ☞ If the gas ballast valve is open, a power failure may cause unintentional ventilation of the pump. In case this constitutes a potential source of danger, take appropriate safety measures (e. g. install a electromagnetic operated gas ballast valve).
- ☞ **Pumps with three phase motor: Check direction of rotation of the motor!** Watch the fan through the fan cover. Let the pump run for a few seconds and check if the fan rotates in the indicated direction. If the direction of rotation is not correct, switch off the pump immediately. Contact your local distributor for further information.
- ☞ When assembling, ensure vacuum-tightness. After assembly, check the complete system for leaks.



During operation:

- ☞ The pump achieves its pumping speed, ultimate total vacuum and vapour pumping rate only at operating temperature (after approx. 30 minutes).
- ☞ Operate the pump without gas ballast only with clean systems and without condensable vapours.
- ☞ Let the pump run with gas ballast to reduce condensation of pumped substances (water vapour, solvents, ...) in the pump or to decontaminate the pump oil from volatile substances. The manual gas ballast valve is open if the arrow on the gas ballast cap shows to the pump.
- ☞ Pumping down can be started at any pressure, max. at atmospheric pressure.
- ☞ Continuous operation is possible at any pressure below atmospheric pressure.
- ☞ Oil consumption increases at inlet pressures above 100 mbar. Check oil level at shorter intervals.
- ☞ In case of pumping aggressive, corrosive or otherwise dangerous gases and vapours, take appropriate measures to protect pump and environment by using appropriate equipment such as cold trap, separator, oil separator, full flow oil filter, shut-off valve as well as special oil.



Shutdown:

Has the pump been exposed to condensate?

- ☞ Allow the pump to continue to run at atmospheric pressure with gas ballast valve open for a few minutes.

Short-term:

- A restart is only possible after two minutes (cool-down period of start-up control (PTC thermistor)).

Long-term:

- Separate pump from the apparatus.
- Flush pump with dry nitrogen.
- Change oil.
- Fill the pump completely with new oil (more than mark Max.!).
- Close manual gas ballast valve.
- Close inlet and outlet port (e. g. with transport caps or blind flanges).
- Store the pump in dry conditions.
- If necessary carry out oil change and maintenance prior to use if the pump is stored longer than one year.

Oil change



Before starting maintenance, isolate the pump from the vacuum system and the electrical supply so that the pump cannot be operated accidentally.



Has the pump been exposed to dangerous or corrosive gases?

Take appropriate safety measures (e. g. safety-clothing and protective goggles) to avoid inhalation and skin contact.

The pump and the oil may be contaminated with pumped chemicals which have been pumped, adopt suitable decontamination measures if necessary.



Aging of the oil necessitates oil change in case of darker colour (see new oil), strange odour of the oil or foreign particles.

Depending on individual cases (especially if corrosive gases or vapours have been pumped) it may be efficient to check the oil at appropriate intervals.

Under normal operating conditions:

- ☞ Check oil level every time before starting the pump.
- ☞ Carry out the first oil change after 100 hours operation time.
- ☞ Change oil on a yearly basis at the latest.
- ☞ Dispose of the used oil, which may be contaminated by chemicals, according to all applicable regulations.



Oil change:

- ☞ Heat pump to operating temperature before changing oil.
- Isolate the pump from the electrical supply and admit air.
- ☞ Choose suitable pad, oil may drop.
- Remove oil drain plug below the rating plate, note O-ring.
- Tilt pump and catch oil in a suitable container.
- ☞ Dispose of the used oil according to the regulations.
- Reassemble oil drain plug with O-ring.
- To flush the pump, pour in fresh oil (approx. 50 ml) through the pump inlet.
- Operate the pump briefly, drain flushing oil and repeat flushing procedure if necessary.
- Remove oil filler plug.
- Fill in fresh oil through the oil inlet port until oil level reaches mark Max..
- Close oil filler plug.



Notes on choosing the correct oil for the application

The **standard oil** for rotary vane pumps is the **B-oil**, a mineral oil, which is used for the first filling of the pump.

The advantages of the B-oil are: Flat viscosity curve, low vapour pressure, good chemical resistance, extended stability when pumping oxidants, acid or basic vapours than conventional mineral oils und good skin compatibility.

Certain pumped media may attack the conventional oil in the pump. Special oils can be used preventively. It is at the users' responsibility to check if the materials of the wetted parts are resistant against the pumped substances. This is also important if special oils are used.

Special oils

Rotary vane pump oil K 8

The rotary vane pump K 8 oil is a special oil designed for pumping acid vapours. The oil is very hygroscopic and has a limited capacity for acids. With decreasing pH, the anticorrosive effect also decreases and it is necessary to change the oil at appropriate intervals. When the pump will stand still for prolonged periods, the oil must be drained and the pump must be filled with mineral oil.

Silicone oil SI 2

Silicone oil SI 2 is used for rotary vane pumps when high aging stability is required.

Because of its chemical nature, the oil is resistant against many aggressive gases, particularly chlorine and hydrochloric acid, solvent vapours and acid or basic solvents.

Synthetic oil (perfluoropolyether oil, e. g. Fomblin®*)

Synthetic oils have an excellent chemical resistance and are certified for pumping pure oxygen. Therefore these oils are excellent for handling strong oxidants, e. g. halogens, nitrogen oxides, etc.

Attention: As perfluoropolyether oils mixed with mineral oils result in an emulsion, pumps used with these oils must be absolutely free of any mineral oil residues.

* reg. trade mark Montedison

Pump oil		cat. no.
B-oil	1 l	68 70 10
	5 l	68 70 11
	20 l	68 70 12
K 8-oil	1 l	68 71 00
	5 l	68 71 01
	20 l	68 71 02
Silicon oil SI 2	1 l	68 75 00
Perfluoropolyether oil	0.5 l	68 76 00

Set of seals RE/RZ 2/5 63 91 45
 Set of seals RE/RZ 8/16 61 12 10

Troubleshooting

Fault	Possible cause	Remedy
<input type="checkbox"/> Pump refuses to start.	<ul style="list-style-type: none"> → Mains plug not connected? → Incorrect supply voltage? → Phase failure? → Oil temperature below 12°C? → Start-up control defective? → Motor thermally overloaded? → Overpressure in the outlet line? 	<ul style="list-style-type: none"> ☞ Insert mains plug. ☞ Connect pump to a suitable supply voltage. ☞ Check fuse. ☞ Operate the pump in suitable ambient conditions. ☞ Contact local distributor. ☞ Switch off, allow the motor to cool (< 50 °C), provide sufficient ventilation. ☞ Open outlet line.
<input type="checkbox"/> Pump operates, but no vacuum.	<ul style="list-style-type: none"> → Measuring procedure or pressure transducer not suitable for the application? → Blocked inlet? → Centering ring not correctly positioned? → Leak in the line or the recipient? → Long, narrow line? → Not enough oil? → Oil contaminated (also solvents)? → Oil of an incorrect type? → Outgasing substances or vapour generated in the process? → Pump not at operating temperature? → None of above mentioned causes? 	<ul style="list-style-type: none"> ☞ Choose suitable procedure. ☞ Ensure that the inlet pipeline does not become blocked. ☞ Check adapter. ☞ Check line and recipient. ☞ Use line with larger diameter. ☞ Top up oil to correct level. ☞ Oil change and flush. ☞ Oil change and flush. ☞ Check process parameters. ☞ Heat pump to operating temperature. ☞ Contact local distributor.

Fault	Possible cause	Remedy
<input type="checkbox"/> Pump too noisy or strange noise.	<ul style="list-style-type: none"> ➔ Too much oil? ➔ Start-up control defective? ➔ None of above mentioned causes? 	<ul style="list-style-type: none"> ☞ Lower oil level to mark Max. ☞ Contact local distributor. ☞ Contact local distributor.
<input type="checkbox"/> Oil in the inlet line.	<ul style="list-style-type: none"> ➔ Back diffusion (small amount of oil, oil film)? ➔ Back streaming (great amount of oil)? 	<ul style="list-style-type: none"> ☞ Install sorption trap or separator if necessary. ☞ Contact local distributor.
<input type="checkbox"/> Oil leakage.	<ul style="list-style-type: none"> ➔ Oil spilled? ➔ None of above mentioned causes? 	<ul style="list-style-type: none"> ☞ Absorb oil and dispose according to regulations. ☞ Contact local distributor.
<input type="checkbox"/> High oil consumption.	<ul style="list-style-type: none"> ➔ High inlet pressure? ➔ Gas ballast operation? ➔ Oil level too high? 	<ul style="list-style-type: none"> ☞ Normal. Top up oil whenever necessary, install outlet filter. ☞ Top up oil level whenever necessary, install outlet filter. ☞ Lower oil level to mark Max.
<input type="checkbox"/> Fast aging of the oil?	<ul style="list-style-type: none"> ➔ Pumping aggressive gases? ➔ Condensation in the pump? 	<ul style="list-style-type: none"> ☞ Use suitable oil. ☞ Use separator or cold trap.



A service manual with exploded view drawings, spare part lists and directions for repair is available on request (only in German or English).

☞ The service manual is for trained service people.

Notes on return to the factory

Repair - return - DKD calibration



Safety and health of our staff, laws and regulations regarding the handling of dangerous goods, occupational health and safety regulations and regulations regarding safe disposal of waste require that for all pumps and other products the "**Health and safety clearance form**" must be sent to our office duly completed and signed before any equipment is dispatched to our premises.

Fax or post a completed copy of the health and safety clearance form to us in advance. The declaration must arrive before the equipment. Enclose a second completed copy with the product. If the equipment is contaminated you must notify the carrier.

No repair / DKD calibration is possible unless the correctly completed form is returned. Inevitably, there will be a delay in processing the equipment if information is missing or if this procedure is not obeyed.



If the product has come in contact with chemicals, radioactive substances or other substances dangerous to health or environment, the product must be decontaminated prior to **sending it back to the factory.**

- ☞ Return the product to us **disassembled and cleaned** and accompanied by a certificate verifying decontamination or
- ☞ Contact an industrial cleaning and **decontamination service** directly or
- ☞ Authorize us to send the product to an industrial cleaning facility **at your expense.**

To expedite repair and to reduce costs, please enclose a detailed description of the problem and the product's operating conditions with every product returned for repair. We submit **quotations** only on request and always at the customer's expense. If an order is given, the costs incurred are offset from the costs for repair or from the purchase price, if the customer prefers to buy a new product instead of repairing the defective one.

☞ **If you do not wish a repair on the basis of our quotation, the equipment might be returned to you disassembled and at your charge!**

In many cases, the **components must be cleaned in the factory** prior to repair.

For cleaning we use an environmentally responsible water based process. Unfortunately the combined attack of elevated temperature, cleaning agent, ultrasonic treatment and mechanical stress (from pressurised water) may result in damage to the paint. Please mark in the health and safety clearance form if you wish a **repaint at your expense** just in case such a damage should occur.

We also replace parts due to optical aspects upon your request.

Before returning the equipment ensure that (if applicable):

- ☞ Oil has been drained and an adequate quantity of fresh oil has been filled in to protect against corrosion.
- ☞ Equipment has been cleaned and/or decontaminated.
- ☞ All inlet and outlet ports have been sealed.
- ☞ Equipment has been properly packed, if necessary, please order an original packaging (costs will be charged), marked as appropriate and the carrier has been notified.
- ☞ Ensure that the completed health and safety declaration is enclosed.



We hope for your understanding for these measures, which are beyond our control.

Scrapping and waste disposal:

Dispose of the equipment and any components removed from it safely in accordance with all local and national safety and environmental requirements. Particular care must be taken with components and waste oil which have been contaminated with dangerous substances from the process. Do not incinerate fluoroelastomer seals and O-rings.

- ☞ You may authorize us to dispose of the equipment **at your expense.**





**Konformitätserklärung
Declaration of conformity
Déclaration de conformité**

Drehschieberpumpe / Rotary vane pump / Pompe à palettes

**RE 2 (230V; 69 70 50, 69 70 53, 69 70 54)
RZ 2 (230V; 69 80 20, 69 80 26, 69 80 27)
RE 5 (230V; 69 70 60, 69 70 63, 69 70 64)
RZ 5 (230V; 69 80 30, 69 80 34, 69 80 37)
RE 8 (230V; 69 70 70, 69 70 76, 69 70 77)
RZ 8 (230V; 69 80 40, 69 8045, 69 80 46)
RE 16 (230V; 69 70 80, 69 70 86, 69 70 87)
RZ 16 (230V; 69 80 50, 69 80 56, 69 80 57)**

Hiermit erklären wir, dass das oben bezeichnete Gerät in Konzeption und Bauart sowie in der von uns in Verkehr gebrachten Ausführung den grundlegenden Anforderungen der zutreffenden, aufgeführten EU-Richtlinien entspricht. Bei einer mit uns nicht abgestimmten Änderung an dem Gerät verliert diese Erklärung ihre Gültigkeit.

We herewith declare that the product designated above is in compliance with the basic requirements of the applicable EC-directives stated below with regard to design, type and model sold by us. This certificate ceases to be valid if the product is modified without the agreement of the manufacturer.

Par la présente, nous déclarons que le dispositif désigné ci-dessus est conforme aux prescriptions de base des directives EU applicables et indiqués en ci que concerne conception, dessin et modèle vendu par nous-mêmes. Cette déclaration cesse d'être valable si des modifications sont apportées au dispositif sans notre autorisation préalable.

Maschinenrichtlinie (mit Änderungen) / Machine directive (with supplements) / Directive Machines (avec des suppléments)

2006/42/EG

Niederspannungsrichtlinie / Low-Voltage Directive / Directive Basse Tension

2006/95/EG

Richtlinie Elektromagnetische Verträglichkeit / Electromagnetic Compatibility Directive / Directive Compatibilité Electromagnétique

2004/108/EG

Angewandte Harmonisierte Normen / Harmonized Standards applied / Normes Harmonisées utilisées

DIN EN 12100-2, DIN EN 61010-1, DIN EN 1012-2, DIN EN 61326-1

Managementsysteme / Management systems / Systèmes de Management

EN ISO 9001, EN ISO 14001 (1997-2006)

Wertheim, 16.04.2008

.....
Ort, Datum / place, date / lieu, date

(Dr. F. Gitmans)

Geschäftsführer / Managing director / Gérant

ppa.

(Dr. J. Dirscherl)

Technischer Leiter / Technical Director / Directeur technique

VACUUBRAND GMBH + CO KG

-Vakuumentchnik im System-
-Technology for Vacuum Systems-
-Technologie pour système à vide-

Alfred-Zippe-Str. 4 - 97877 Wertheim/Germany

Tel.: +49 9342 808-0 - Fax: +49 9342 808-450

E-Mail: info@vacuubrand.de

Web: www.vacuubrand.com



Disclaimer: Our technical literature is only intended to inform our customer. The validity of general empirical values and results obtained under test conditions for specific applications depend on a number of factors beyond our control. It is therefore strictly the users' responsibility to very carefully check the validity of application to their specific requirements. No claims arising from the information provided in this literature will, consequently, be entertained.

VACUUBRAND GMBH + CO KG
-Technology for Vacuum Systems-

© 2008 VACUUBRAND GMBH + CO KG Printed in Germany

Alfred-Zippe-Str. 4 - 97877 Wertheim/Germany
Tel.: +49 9342 808-0 - Fax: +49 9342 808-450
E-Mail: info@vacuubrand.de
Web: www.vacuubrand.com

