

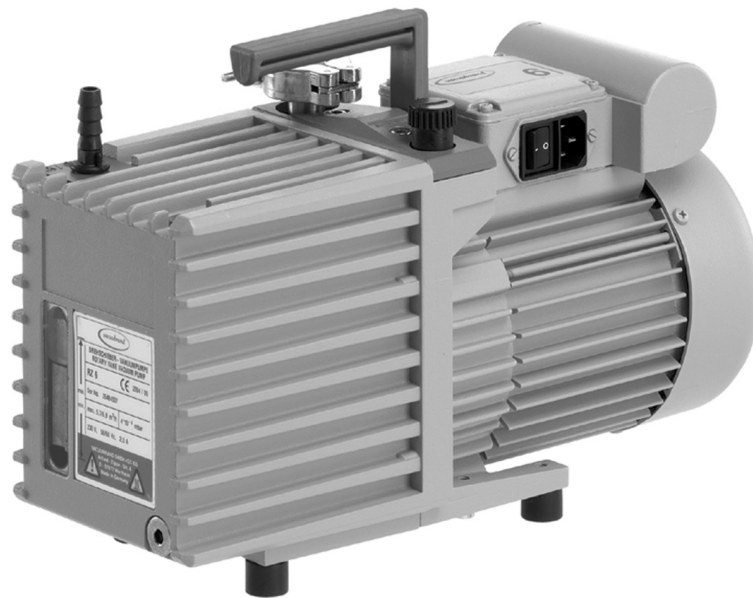

Technology for Vacuum Systems
Instructions for use



RE 2.5 - RZ 2.5

RE 6 - RZ 6

RE 9 - RZ 9

RE 16 - RZ 16

Rotary vane pumps

Dear customer,

Your VACUUBRAND pumps are designed to provide you with many years of trouble-free service with optimal performance. Through our long experience in design, construction and operation of vacuum pumps, combined with the latest developments in material and manufacturing technology, we have accumulated a wealth of application and safety insights that we want to share with you.

Please read these instructions for use before the initial operation of your pump.

Our quality maxim is the "zero fault principle":

Every rotary vane pump, before leaving our factory, is tested intensively, including an endurance run of 60 hours. Any faults, even those which occur rarely, are identified and can be eliminated immediately.

After completion of the endurance run, every pump is tested, and must achieve specifications before shipment.

We are committed to providing our customers only pumps that meet this high quality standard.

While our pumps cannot eliminate all of your work, we design, manufacture and test them to ensure that they will be an effective and trouble-free tool to assist you in that work.

Yours,

VACUUBRAND GMBH + CO KG

After sales service:

Contact your local dealer or call +49 9342 808-5500.

Trademark index:

VACUU•LAN® (US-Reg.No 3,704,401), VACUU•BUS®, VACUU•CONTROL™, chemistry-HYBRID™, Peltronic®, TURBO•MODE™, VARIO® (US-Reg.No 3,833,788), VARIO-SP™, VACUUBRAND® (US-Reg.No 3,733,388) and also the shown company logos are trademarks of VACUUBRAND GMBH + CO KG in Germany and/or other countries.

Contents

Safety information!	4
Important information!	4
General information	6
Intended use.....	6
Setting up and installing the equipment	7
Ambient conditions	10
Operating conditions	11
Safety during operation	12
Maintenance and repair.....	15
Technical data	17
General technical data valid for all pumps	17
Gas inlet temperatures	17
Wetted parts	21
Abbreviations.....	21
Pump parts	21
Replacing the device fuses	24
Use and operation	26
Installing a pump in a vacuum system	26
During operation.....	28
Important notes regarding the use of gas ballast	30
Shutdown & storage.....	31
Oil change	32
Oil change procedure	33
Notes on choosing the appropriate oil for the application	34
Accessories	36
Troubleshooting	39
Notes on return to the factory	41
Warranty	44
Health and safety clearance form	45
EC Declaration of Conformity of the Machinery	46

Safety information!

Important information!

WARNING

- ☞ Keep this manual complete and accessible to personnel at all times!
- ☞ Read this manual carefully before installing or operating the equipment. Observe the instructions contained in this manual.
- ☞ Do not modify the equipment without authorization.

NOTICE

This manual is an integral part of the equipment described therein. It describes the safe and proper use of the vacuum pump.

Make operating personnel aware of dangers arising from the pump and the pumped substances.

VACUUBRAND disclaims any liability for inappropriate use of these pumps and for damage from failure to follow instructions contained in this manual.

This manual is only to be used and distributed in its complete and original form. It is strictly the users' responsibility to check carefully the validity of this manual with respect to his product.

Manual-no.: 999139 / 11/20/2013

The following signal word panels and safety symbols are used throughout this manual:



This is the safety alert symbol. It is used to alert you to potential personal injury hazards. Obey all safety messages that follow this symbol to avoid possible injury and death.



➔ DANGER indicates a hazardous situation which, if not avoided, will result in death or serious injury.



☞ WARNING indicates a hazardous situation which, if not avoided, could result in death or serious injury.



• CAUTION indicates a hazardous situation which, if not avoided, could result in minor or moderate injury.



NOTICE is used to address practices not related to personal injury.



Caution! Hot surface!



Disconnect equipment from AC power.

Formatting used in this manual:

Note: The signal word panels in all sections of this manual always refer to all paragraphs of the same format (➔ / ☞ / • / plain text) following each signal word panel.

The document "Safety information for vacuum equipment" is part of this manual! Read the "Safety information for vacuum equipment" and observe the instructions contained therein!

General information

NOTICE

Remove all packing material from the packing box. Remove the product from its packing-box and retain all packaging until the equipment is inspected and tested. Remove the protective caps from the inlet and outlet ports and retain for future use. Inspect the equipment promptly and carefully.

If the equipment is damaged, notify the supplier and the carrier in writing within three days. Retain all packing material for inspection. State the item number of the product together with the order number and the supplier's invoice number. Failure to check and give notice of damage will void any and all warranty claims for those deficiencies.

Replace the protective caps, if the equipment is not used immediately. Store the equipment in dry and non-corrosive conditions (see also "Technical data", pg. 17).

WARNING

 **Do not use any damaged equipment.**

CAUTION

- Check the pump's oil level.
- If the pump is delivered without oil filling, fill in oil, see section "Oil change", pg. 32.
- Aging of the oil (as indicated by darker color compared to new oil, strange odor of the oil, particles in the oil, or contamination) necessitates an oil change.
- Use the handle when moving the pump.

Intended use

WARNING

 Do not use the pump or any system parts on humans or animals.

 Ensure that the individual components are only connected, combined and operated according to their design and as indicated in the instructions for use. Use only **original manufacturer's spare parts and accessories**. Otherwise the safety and performance of

the equipment, as well as the electromagnetic compatibility of the equipment might be reduced.

The CE mark or the cTÜVus mark may be voided if not using original manufacturer's spare parts.

- ☞ Comply with all notes on correct vacuum and electrical connections; see section "Use and operation", pg. 26.

- ☞ Do not use the pump to generate pressure.

- ☞ The pumps are designed for **ambient temperatures** during operation between +54°F and +104°F (+12°C and +40°C). Periodically check maximum temperatures if installing the pump in a cabinet or a housing. Make sure ventilation is adequate to maintain recommended operating temperature. Install an external automatic ventilation system if necessary. If pumping hot process gases, make sure that the maximum permitted gas inlet temperature is not exceeded. The maximum permitted gas inlet temperature depends on several parameters like inlet pressure and ambient temperature (see "Technical data", pg. 17).

- ☞ Particles and dust must not enter the pump.
- ☞ Do not pump liquids.

CAUTION

- Ensure that the pump is chemically resistant to the pumped substances prior to operation.

NOTICE

Use the equipment **only as intended**, that is, for generation of vacuum in vessels designed for that purpose. Any other use will automatically invalidate all warranty and liability claims. Remain aware of safety and risks.

Setting up and installing the equipment

DANGER

- ➔ Equipment must be connected only to a **suitable electrical supply** and a suitable ground point. As such, the plug must be plugged into an outlet that is properly

grounded. Failure to connect the motor to ground may result in deadly electrical shock.

The supply cable may be fitted with a molded European IEC plug or a plug suitable for your local electrical supply. The cable contains wires color coded as follows: green or green and yellow: ground; blue or white: neutral; brown or black: hot.

⚠ WARNING

- ☞ Due to the high compression ratio, the pump may generate overpressure at the outlet. Check pressure compatibility with system components (e.g., exhaust pipeline or exhaust valve) at the outlet.
- ☞ Do not permit any **uncontrolled pressurizing**. Make sure that the exhaust tubing cannot become blocked. If there is an exhaust isolation valve, make sure that you cannot operate the equipment with the valve closed to avoid a **risk of bursting!**
- ☞ Keep the electrical power cord away from heated surfaces.

⚠ CAUTION

- Provide a firm, level platform for the equipment. Check that the system which you are going to evacuate is mechanically stable. Check that all fittings are secure. Ensure a stable position of the pump without any mechanical contact other than the pump feet.
- Comply with **maximum permissible pressures** at inlet and outlet and with **maximum permissible pressure differences** between inlet and outlet. See section “Technical data”, pg. 17. Do not operate the pump with overpressure at the inlet.
- Avoid overpressure of more than 17.5 psi absolute (1.2 bar absolute) in the event that inert gas is connected to the pump, to the gas ballast or to a venting valve.
- **Note:** Flexible elements will shrink when evacuated.
- Connect hoses gas tight at inlet and outlet of the pump.
- Ensure that no foreign objects can be drawn into the pump.

- Check the power source and the pump's rating plate to be sure that the power source and the equipment match in voltage, phase, and frequency.
- **Pump with dual-voltage motor:** Check that the voltage selection switch is positioned correctly. Check every time before starting the pump.
Note: If the pump is switched on with wrong voltage selection, the motor may be damaged!
Change the selection at the voltage selection switch only, if the pump is unplugged from the power source.
- **Direction of rotation** of pumps with three-phase motors: Pumps with three-phase motors wired ready for connection are supplied with a power plug (CEE). The electrical wiring is laid out for a right-handed rotary field.
Checking the direction of rotation:
Switch on pump for a few seconds and check if the pump aspirates at inlet. If no suction occurs switch off pump immediately. The three phase socket has to be checked and if necessary corrected by an electrician.
- Use only oil of the recommended type. Other oils or operating fluids may cause damage of the pump or danger.
- Use **special oils** (see "Oil change", pg. 32) for the rotary vane pump, if, e.g.,
 - acid vapors are pumped.
 - extremely high aging stability is required.
 - oxygen or other strong oxidizing agents are pumped.
- Take adequate precautions when handling pump fluids, lubricants, and solvents. Use appropriate protective clothing, safety goggles and protective gloves to avoid excessive contact with the skin and possible skin irritations (including dermatitis).
- Comply with all relevant statutory requirements and regulations concerning the handling, storage and disposal of oil.

NOTICE

Make sure ventilation is adequate to maintain recommended operating temperature. Keep a minimum distance of 2 in (5 cm) between the cooling fan and surrounding items (e.g., housing, walls, etc.), or else install an external automatic ventilation system. Check fan regularly for dust/dirt. Clean fan guard grill if necessary to avoid a reduction of ventilation.

Use only hoses at the inlet and outlet of the pump with an inner diameter at least as large as the diameter of the pump's connections (to avoid overpressure at the outlet, and reduction of pumping speed at the inlet).

Allow the equipment to equilibrate to ambient temperature if you bring it from cold environment into a room prior to operation. Notice if there is water condensation on cold surfaces.

Comply with all **applicable and relevant safety requirements** (regulations and guidelines). **Implement the required actions and adopt suitable safety measures.**

Ambient conditions**! DANGER**

- ➔ Do not reach for this product if it has fallen into liquid. There is a risk of deadly electrical shock. Unplug the system immediately.

! WARNING

- ☞ Do not use this product in an area where it can fall or be pulled into water or other liquids.

! CAUTION

- Adopt suitable measures in case of differences from recommended conditions, e.g., using the equipment outdoors, installation in higher altitudes, conductive pollution or external condensation on the pump.
- Do not operate this product near flames.

NOTICE

To the best of our knowledge the equipment is in compliance with the requirements of the applicable EC-directives and harmonized standards (see "Declaration of Conformity") with regard to design, type and model. Directive EN 61010-1 gives in detail the conditions under which the equipment can be operated safely (see also IP degree of protection, "Technical data", pg. 17).

Operating conditions**DANGER**

- ➔ These pumps are not approved for operation in potentially explosive atmospheres. **Do not operate the pumps in potentially explosive atmospheres.**
- ➔ These pumps are not approved for the pumping of potentially explosive atmospheres. **Do not pump potentially explosive atmospheres.**

- ➔ The pumps are **not suitable** to pump any of the substances listed below.
Do not pump:
 - **unstable substances**
 - substances which react explosively under **impact** (mechanical stress) without air
 - substances which react explosively when being exposed to **elevated temperatures** without air,
 - **self inflammable** substances,
 - substances which are **inflammable without air**
 - **explosive substances.**

- ➔ The pumps are **not approved** for operation below ground. **Do not operate** the pump **below ground.**

CAUTION

- **Do not pump** substances which may form **deposits** inside the pump. The pumps are not suitable for pumping substances which may form deposits inside the pump. Deposits and condensate in the pump may lead to increased temperatures even to the point of exceeding the maximum permitted temperatures. Deposits may cause seizing of the pump unit.

- Check the inlet and outlet of the pump and its oil condition, if there is a danger of forming **deposits** inside the pump, e.g., in the pump unit. Inspect the pump regularly and clean if necessary.
- Install a cold trap in front of the pump if pumping aggressive or corrosive gases or vapors.
- **Consider interactions and chemical reactions of the pumped media.** Ensure that the materials of the pump's wetted parts are compatible with the pumped substances, see section "Technical data", pg. 17. When changing the substances pumped, we recommend purging the pump with air or inert gas prior to changing the pumped media. Purging the pump will pump out residues and it will reduce the possibility of reactions of the pumped substances with each other and with the pump's materials.

Safety during operation



- ➔ Adopt suitable measures to prevent the release of dangerous, toxic, explosive, corrosive, noxious or polluting fluids, vapors and gases. To prevent any emission of such substances from the pump outlet, install an appropriate collecting and disposal system and take protective action for pump and environment.
- ➔ You must take suitable precautions to prevent any formation of explosive mixtures in the expansion chamber, in the oil reservoir, or at the outlet of the pump. In such circumstances, mechanically generated sparks, hot surfaces or static electricity may ignite these mixtures. Use inert gas for gas ballast or venting, if necessary.
- ➔ Drain appropriately or otherwise remove any potentially explosive mixtures at the outlet of the pump, or dilute them to non-explosive concentrations.

- ➔ Never operate this pump if it has a damaged cord or plug.

⚠ WARNING

- ☞ If the pump is not working properly, has been dropped or has fallen into water, contact your pump service provider.
- ☞ Prevent any part of the human body from coming into contact with vacuum.
- ☞ Always provide a free and pressureless exhaust outlet. Make sure that the exhaust tubing cannot become blocked.
- ☞ Comply with applicable regulations when disposing of chemicals. Take into consideration that chemicals may be contaminated. Take adequate precautions to protect people from the effects of dangerous substances (chemicals, oil mist, thermal decomposition products of fluoroelastomers). Use appropriate protective clothing and safety goggles.
- ☞ Failure of the pump (e.g., due to power interruption), failure of connected components or of parts of the supply, or a change of parameters must not be allowed to lead to a dangerous situation under any circumstances. In case of a leak in the manifold or at the shaft seal, pumped substances might be released into the environment or into the pump housing or motor. Especially comply with notes on use and operation and maintenance.
- ☞ The residual **leak rate of the equipment** might render possible an exchange of gas, albeit extremely slight, between the environment and the vacuum system. Adopt suitable measures to prevent contamination of the pumped substances or the environment.

⚠ CAUTION

- Ensure that no parts of your clothing, hair or fingers can be caught or drawn in at the inlet of the pump. Never insert fingers or drop any other object into the

inlet or outlet.

- Pumping at high inlet pressure may lead to overpressure at the gas ballast valve. Pumped gases or condensate might be expelled if the valve is open. If an inert gas supply is connected to the gas ballast, ensure that its inlet pipeline is not contaminated.
- Check oil level of the rotary vane pump (through sight glass) every time before starting the pump.



- Pay attention to the safety symbol "hot surfaces" on the equipment.

During operation the surface temperature of the pumps may exceed 176°F (80°C). Make sure not to touch the pumps accidentally.

Hot parts may cause burns if touched. Adopt suitable measures to prevent any danger arising from hot surfaces or electric sparks. Ensure that hot surfaces of the pump do not cause burns. Provide a suitable contact guard if necessary.

- A power failure may cause accidental ventilation of the pump or the vacuum system, if the manual gas ballast valve (RE 2.5 / RZ 2.5 / RE 6 / RZ 6 / RE 9 / RZ 9) is open. If this constitutes a potential source of danger, take appropriate safety measures, e.g., install a solenoid operated gas ballast valve.

NOTICE

Prevent the backpressure of gases and the backflow of condensates at the outlet.

Provide appropriate protective measures to allow for the possibility of failure and **malfunction**. The protective measures must also allow for the requirements of the respective application.

Single-phase motors are protected by a self-hold thermal cutout in the winding.

Three-phase motors are protected by a circuit-breaker isolating all poles in case of overload.

Note: Only manual reset is possible. Switch off the pump and disconnect from the power source. Identify and eliminate the cause of failure. Wait approx. five minutes before restarting the pump.

Maintenance and repair

NOTICE

In order to comply with laws (occupational, health and safety regulations, safety at work law and regulations for environmental protection) vacuum pumps, components and measuring instruments can only be returned when certain procedures (see section “Notes on return to the factory”, pg. 41) are followed.

Take advantage of our service seminars, which put special focus on the maintenance and repair of vacuum pumps. For details see www.vacuubrand.com.

Bearings have a typical durability of 40000 h. Motor capacitors have a typical durability in the range of 10000 to 40000 h depending strongly on operation conditions including ambient temperature, humidity or load.

! DANGER



- ➔ **Ensure that the pump cannot be operated accidentally. Never operate the pump if covers or other parts of the pump are disassembled.**
- ➔ **Switch off the pump. Disconnect the electrical power cord and wait five seconds** before starting maintenance to allow the capacitors to discharge.
- ➔ **Note:** The pump may be contaminated with process chemicals, which have been pumped during operation. Ensure that the pump is completely decontaminated before maintenance commences. Avoid the release of pollutants.

! WARNING

- ☞ Take adequate precautions to protect people from the effects of dangerous substances if contamination has

occurred. Use appropriate protective clothing, safety goggles and protective gloves.

- ☞ **Wear parts have to be replaced regularly.**
- ☞ **Never operate a defective or damaged pump.**

- ☞ Check every motor capacitor regularly by measuring its capacity and estimating its time in operation. Replace old capacitors early enough to prevent a failure in operation. If an old motor capacitor fails, the capacitor may get hot. It may even melt or emit a flame, which could be **dangerous for persons and equipment in the vicinity**. The capacitors have to be replaced by an electrician.

- ☞ Vent the pump before starting maintenance. Isolate the pump and other components from the vacuum system. Allow sufficient cooling of the pump. Drain condensate, if applicable.

NOTICE

Ensure that **maintenance** is done only by suitably trained and supervised technicians. Ensure that the maintenance technician is familiar with the safety procedures, which relate to the products processed by the pumping system.

Technical data

General technical data valid for all pumps		
Maximum permissible inlet pressure (absolute)	psi (bar)	16 (1.1)
Maximum permissible outlet pressure (absolute)	psi (bar)	16 (1.1)
Maximum pressure difference between inlet and outlet	psi (bar)	16 (1.1)
Maximum permissible pressure (absolute) at gas ballast valve	psi (bar)	17.5 (1.2)
Permissible ambient temperature storage / operation	°F (°C)	14 to 140 / 54 to 104 (-10 to +60 / +12 to +40)
Permissible relative atmospheric moisture during operation (no condensation)	%	30 to 85
Maximum permissible installation altitude above mean sea level	ft (m)	6500 (2000)
No-load speed 50/60 Hz	rpm	1500 / 1800
Motor protection single-phase motor three-phase motor		self-hold thermal cutout, manual reset circuit-breaker isolating all poles in case of overload
Degree of protection IEC 529		IP 40
Water vapor tolerance	Torr (mbar)	30 (40)
Recommended oil		VACUUBRAND B-oil

Gas inlet temperatures

Operating condition	Inlet pressure	Permitted range of gas temperatures at inlet
Continuous operation	> 75 Torr (100 mbar) (high gas load)	➡ 50 °F to 104 °F (+10°C to +40°C)
Continuous operation	< 75 Torr (100 mbar) (low gas load)	➡ 32 °F to 140 °F (0°C to +60°C)
Short-time (< 5 minutes)	< 75 Torr (100 mbar) (low gas load)	➡ 14 °F to 176 °F (-10°C to +80°C)

Type		RE 2.5	RE 6	RZ 2.5	RZ 6
Maximum pumping speed 50/60 Hz (ISO 21360)	cfm (m ³ /h)	1.4 / 1.7 (2.3 / 2.8)	3.4 / 4.0 (5.7 / 6.8)	1.4 / 1.7 (2.3 / 2.8)	3.4 / 4.0 (5.7 / 6.8)
Ultimate partial pressure without gas ballast	Torr (mbar)	2.3*10 ⁻¹ (3*10 ⁻¹)	7.5*10 ⁻² (1*10 ⁻¹)	3*10 ⁻⁴ (4*10 ⁻⁴)	3*10 ⁻⁴ (4*10 ⁻⁴)
Ultimate total pressure without gas ballast	Torr (mbar)	2.3*10 ⁻¹ (3*10 ⁻¹)	7.5*10 ⁻² (1*10 ⁻¹)	1.5*10 ⁻³ (2*10 ⁻³)	1.5*10 ⁻³ (2*10 ⁻³)
Ultimate total pressure with gas ballast	Torr (mbar)	6*10 ⁻¹ (8*10 ⁻¹)	4.5*10 ⁻¹ (6*10 ⁻¹)	7.5*10 ⁻³ (1*10 ⁻²)	7.5*10 ⁻³ (1*10 ⁻²)
Oil capacity min./max.	quarts (ml)	0.19 / 0.54 (180 / 510)	0.38 / 0.98 (360 / 930)	0.11 / 0.30 (100 / 280)	0.36 / 0.77 (340 / 730)
Rated motor power (single-phase/three-phase)	hp (kW)	0.24 / - (0.18 / -)	0.4 / - (0.3 / -)	0.24 / - (0.18 / -)	0.4 / 0.4 (0.3 / 0.3)
Maximum permissible range of supply voltage Attention: Observe speci- fications of rating plate!		120 V~ +5%/-10% 60 Hz 230 V~ ±10% 50/60 Hz 400 V 3~ ±10% 50 Hz 100-115 V~ ±10% 50/60 Hz, 120 V~ ±10% 60 Hz, 200-230 V~ ±10% 50/60 Hz 100-120 V~ ±10% 50/60 Hz 200-230 V~ ±10% 50/60 Hz			
Rated current ^{a.)} during operation at:					
120 V~ 60 Hz	A	3.0	4.6	3.0	4.6
230 V~ 50/60 Hz	A	1.6 / 1.5	2.5 / 2.4	1.6 / 1.5	2.5 / 2.4
400 V 3~ 50 Hz	A	-	-	-	0.8
100-115 V~ 50/60 Hz/ 120 V~ 60 Hz	A	4.0 / 2.6	-	4.0 / 2.6	-
200-230 V~ 50/60 Hz	A	2.0 / 1.3	-	2.0 / 1.3	-
100-120 V~ 50/60 Hz	A	-	5.4 / 4.0	-	5.4 / 4.0
200-230 V~ 50/60 Hz	A	-	2.7 / 2.0	-	2.7 / 2.0
Fuse (slow blow fuse), only pumps with dual-voltage motor		2 x 10 AT 250 VAC, 5 x 20 mm, breaking capacity: 1000 A at 250 VAC			
Inlet		small flange KF DN 16 ^{b.)}			
Outlet		hose nozzle for tubing I.D. 3/8" (hose nozzle DN 10 mm)			
A-weighted emission sound pressure level ^{c.)} (uncertainty K _{pA} : 3 dB(A))	dB(A)	43	50	43	50

Type		RE 2.5	RE 6	RZ 2.5	RZ 6
Dimensions L x W x H approx. (without handle)	in (mm)	12.4 x 4.9 x 7.5 ^{d.)} (316 x 125 x 190 ^{d.)})	14.6 x 5.6 x 8.1 ^{e.)} (370 x 142 x 207 ^{e.)})	12.4 x 4.9 x 7.5 ^{d.)} (316 x 125 x 190 ^{d.)})	14.6 x 5.6 x 8.1 ^{e.)} (370 x 142 x 207 ^{e.)})
Weight with oil filling approx. 120 V / 230 V / 400 V	lbs. (kg)	23.1 / 22.5 / - ^{f.)} (10.5 / 10.2 / - ^{f.)})	34.8 / 34.0 / - ^{g.)} (15.8 / 15.4 / - ^{g.)})	25.6 / 25.1 / - ^{h.)} (11.6 / 11.4 / - ^{h.)})	37.0 / 36.2 / 37.3 ^{i.)} (16.8 / 16.4 / 16.9 ^{i.)})

- a.) When the pump is starting, the current draw might for a short period (depending on the ambient temperature) be two or three times as high as during operation.
- b.) 120V version: Additional adapter small flange KF DN 16 / hose nozzle DN 10 mm (material: PP)
- c.) Measurement according to EN ISO 2151:2004 and EN ISO 3744:1995 at 230V/50Hz and at ultimate vacuum with exhaust tube at outlet.
- d.) Dimensions of **120V version**: 12.4" x 5.2" x 6.9" (316mm x 133mm x 175mm),
Dimensions of **100-120/200-230V version**: 12.4" x 5.1" x 7.9" (314mm x 130mm x 200mm)
- e.) Dimensions of **400V version**: 14.6" x 5.6" x 8.5" (370mm x 142mm x 216mm)
Dimensions of **100-120/200-230V version**: 14.6" x 5.6" x 8.5" (370mm x 142mm x 217mm)
- f.) Weight of RE 2.5 **100-120/200-230V version**: 26.0lbs. (11.8kg)
- g.) Weight of RE 6 **100-120/200-230V version**: 34.6lbs. (15.7kg)
- h.) Weight of RZ 2.5 **100-120/200-230V version**: 28.7lbs. (13.0kg)
- i.) Weight of RZ 6 **100-120/200-240V version**: 37.3lbs. (16.9kg)

We reserve the right for technical modification without prior notice!

Type		RE 9	RE 16	RZ 9	RZ 16
Maximum pumping speed 50/60 Hz (ISO 21360)	cfm (m ³ /h)	5.2 / 6.0 (8.9 / 10.2)	9.8 / 11.1 (16.6/19.1)	5.2 / 6.0 (8.9 / 10.2)	9.8 / 11.1 (16.6/19.1)
Ultimate partial pressure without gas ballast	Torr (mbar)	7.5*10 ⁻² (1*10 ⁻¹)	7.5*10 ⁻² (1*10 ⁻¹)	3*10 ⁻⁴ (4*10 ⁻⁴)	3*10 ⁻⁴ (4*10 ⁻⁴)
Ultimate total pressure without gas ballast	Torr (mbar)	7.5*10 ⁻² (1*10 ⁻¹)	7.5*10 ⁻² (1*10 ⁻¹)	1.5*10 ⁻³ (2*10 ⁻³)	1.5*10 ⁻³ (2*10 ⁻³)
Ultimate total pressure with gas ballast	Torr (mbar)	4.5*10 ⁻¹ (6*10 ⁻¹)	4.5*10 ⁻¹ (6*10 ⁻¹)	7.5*10 ⁻³ (1*10 ⁻²)	7.5*10 ⁻³ (1*10 ⁻²)
Oil capacity min./max.	quarts (ml)	0.42 / 1.48 (400/1400)	0.32 / 1.06 (300/1000)	0.21 / 0.85 (200/800)	0.53 / 1.06 (500/1000)
Rated motor power (single-phase/three-phase)	hp (kW)	0.50 / - (0.37 / -)	0.74 / - (0.55/0.55)	0.5 / 0.5 (0.37/0.37)	0.74 / 0.74 (0.55/0.55)
Maximum permissible range of supply voltage Attention: Observe speci- fications of rating plate!		120 V~ +5%/-10% 60 Hz 230 V~ ±10% 50/60 Hz 400 V 3~ ±10% 50 Hz			
Rated current during operation at: 120 V~ 60 Hz a.) 230 V~ 50/60 Hz a.) 400 V 3~ 50 Hz	A A A	- 2.7 / 2.6 -	- 4.5 / 3.7 1.4	5.3 2.7 / 2.6 1.1	- 4.5 / 3.7 1.4
Inlet		small flange KF DN 25 b.)			
Outlet		small flange KF DN 25 b.)			
A-weighted emission sound pressure level c.) (uncertainty K _{pA} : 3 dB(A))	dB(A)	52	54	52	54
Dimensions L x W x H approx. (without handle)	in (mm)	18.1 x 6.0 x 9.1 (460 x 152 x 232)	19.9 x 6.0 x 9.1 (505 x 152 x 232)	18.1 x 6.0 x 9.1 (460 x 152 x 232)	21.5 x 6.0 x 9.1 (545 x 152 x 232)
Weight with oil filling approx.	lbs. (kg)	47.2 (21.4)	55.6 (25.2)	53.4 (24.2)	63.9 (29.0)

a.)When the pump is starting, the current draw might for a short period (depending on the ambient temperature) be two or three times as high as during operation.

RE/RZ 9: During the start-up period of the pump (first 6 minutes after switching-on) the current draw might be elevated (up to twice the given rated current draw).

b.)120V version: Additional adapter small flange KF DN 25 / hose nozzle DN 15 mm (material: PP)

c.)Measurement according to EN ISO 2151:2004 and EN ISO 3744:1995 at 230V/50Hz and at ultimate vacuum with exhaust tube at outlet.

We reserve the right for technical modification without prior notice!

Wetted parts

Components	Wetted materials
Metal parts	aluminum alloy, stainless steel, grey cast iron, steel (partly plasma nitrated), nickel-plated, zinc
Plastic materials	epoxy resin, FPM, NBR, PBT, PEEK, PPS glass-fiber reinforced

We reserve the right for technical modification without prior notice!

Abbreviations

- FPM:** Fluoroelastomer
NBR: Nitrile butadiene rubber
PBT: Polybutylene terephthalate
PEEK: Polyether ether ketone
PPS: Polyphenylene sulfide

Pump parts

Position	Component
1	Inlet
2	Outlet
3	Manual gas ballast valve
4	ON/OFF switch
5	Power connection
6	Handle
7	Rating plate with min. / max. mark for oil level
8	Oil inlet
9	Oil outlet
10	Sight glass for oil level
11	ON/OFF switch for solenoid operated gas ballast valve
12	Voltage selection switch
13	Internal fuse

RE 2.5 / RZ 2.5 / RE 6 / RZ 6 with dual-voltage motor (fig. RE 6)

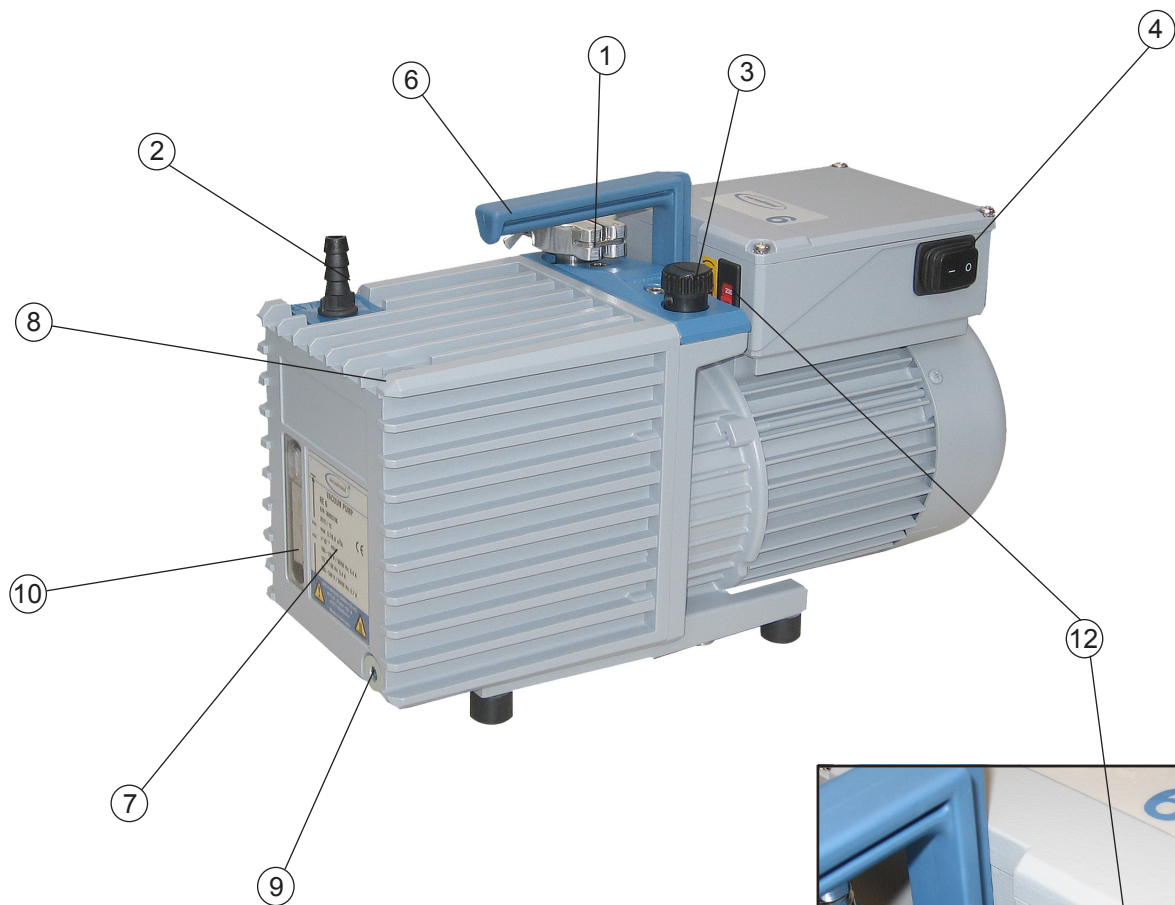

Voltage selection switch

- ☞ Check that the voltage selection switch at the terminal box is positioned correctly. Check every time before starting the pump.

Note: If the pump is switched on with wrong voltage selection, the motor may be damaged!

Change the selection at the voltage selection switch only if the pump is unplugged from the power source.



- 1. Disconnect the electrical power cord.**
- Adjust the **voltage selection switch** to the supply voltage:
"115" corresponds to 100-120V and
"230" corresponds to 200-230V.

Terminal box RE 2.5 / RZ 2.5 / RE 6 / RZ 6 with dual-voltage motor



Replacing the device fuses

DANGER

➔ Switch off the pump.



➔ Disconnect the electrical power cord before unscrewing the fuse holder.

Identify and eliminate the cause of failure before switching on the pump again.

CAUTION

• Double pole / neutral fusing:

The pump has two fuses and might have live circuits, even when one fuse has blown or has been removed. Switch off the pump or disconnect the electrical power cord before replacing fuses.

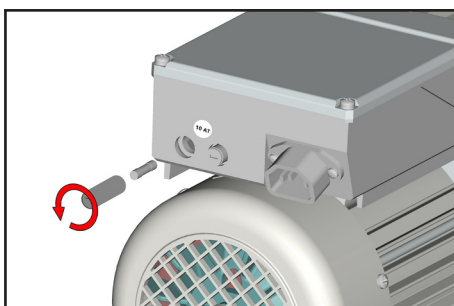

➔ Unscrew the fuse holder at the terminal box of the pump using a slotted screw driver.

➔ Replace the defective fuse by a fuse of the same type (see “Technical data”, pg. 17). Reassemble holder with fuse to the pump.

RE 9 / RZ 9

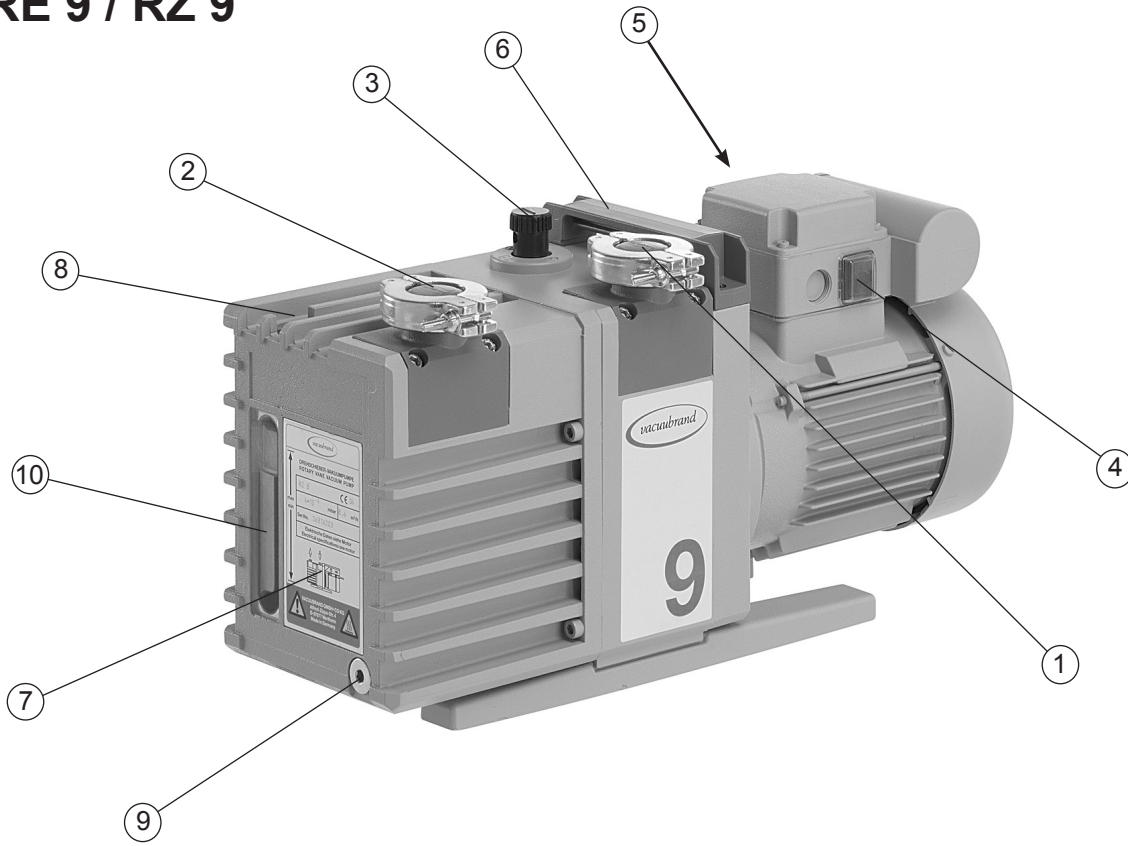

RE 16 / RZ 16

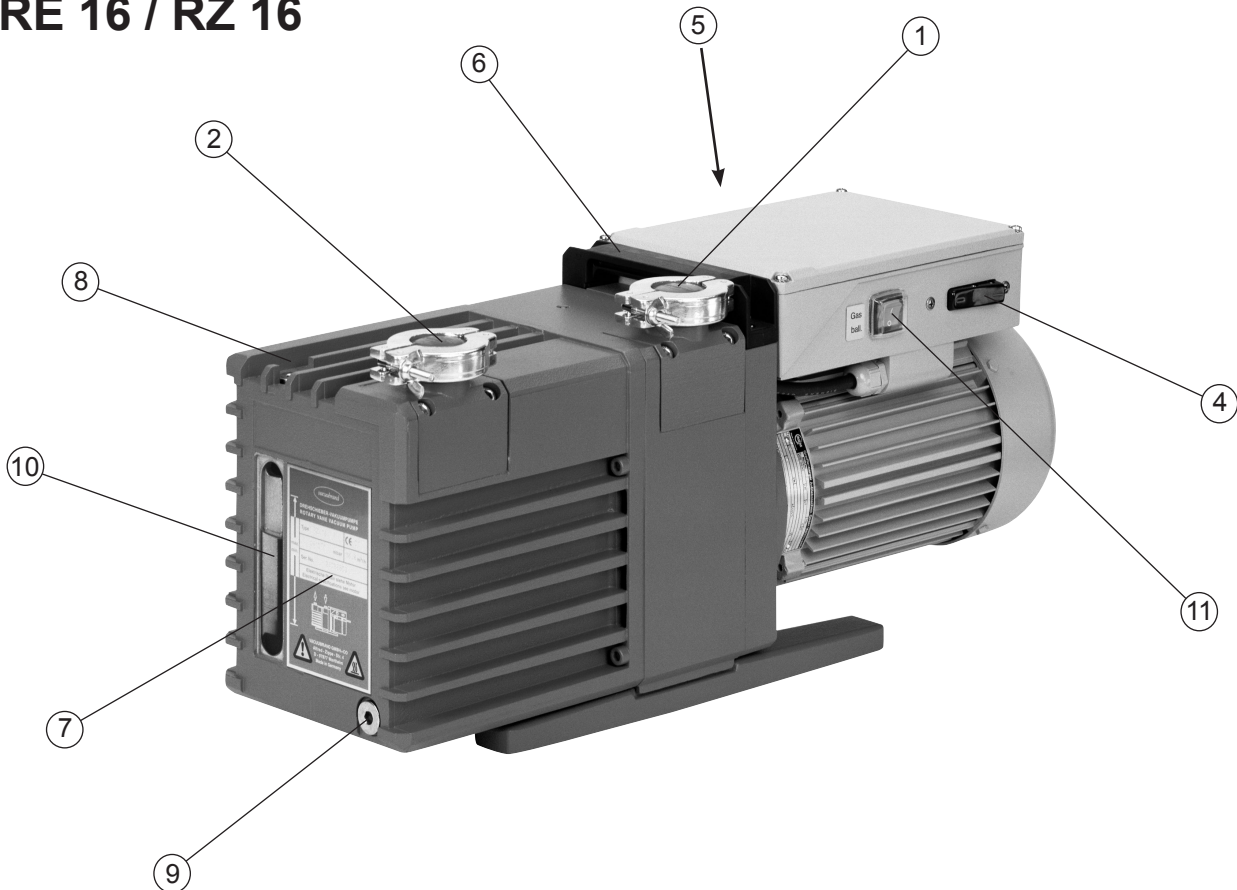

Use and operation

Installing a pump in a vacuum system

DANGER

- ➔ If dangerous or polluting fluids (e.g., oil mist) could be released at the outlet, install an appropriate system (e.g., oil mist separator, see “Accessories”, pg. 36) to catch and dispose of those fluids.

WARNING

- ☞ Connect a gas-tight exhaust line at the pump outlet if necessary. Always vent exhaust gases appropriately (e.g., into a fume hood).
- ☞ Never block the gas outlet. The exhaust line must always be free of obstructions (no back pressure) to ensure an unimpeded discharge of gas. The cross-section of the outlet tubing must be at least the size of the pump's exhaust connection.
- ☞ Particles and dust must not be aspirated. If necessary, you must install appropriate filters. You must ensure their suitability concerning gas flow, chemical resistance and resistance to clogging prior to use.
- ☞ Make sure ventilation is adequate, especially if the pump is installed in an enclosure, or if the ambient temperature is elevated. Provide external ventilation, if necessary.

CAUTION

- Reduce the transmission of vibration. Prevent mechanical load due to rigid pipelines. Insert elastic hoses or flexible elements as couplings between the pump and rigid pipes.
Note: Flexible elements will compress or flatten when evacuated if not designed for use under vacuum.
- Hose connections at the pump inlet must always be gas tight.
- Install a cold trap in front of the pump, if pumping aggressive or corrosive gases or vapors.

- A power failure may cause accidental ventilation of the pump or the vacuum system, especially if the manual gas ballast valve (RE 2.5 / RZ 2.5 / RE 6 / RZ 6 / RE 9 / RZ 9) is open. If this constitutes a potential source of danger, take appropriate safety measures, e.g., install a solenoid operated gas ballast valve (see “Accessories”, pg. 36).
- Check the power source and the pump’s rating plate to be sure that the power source and the equipment match in voltage, phase, and frequency.
- **Pump with dual-voltage motor:** Check that the voltage selection switch at the terminal box is positioned correctly. Check every time before starting the pump.
Note: If the pump is switched on with wrong voltage selection, the motor may be damaged!
Change the selection at the voltage selection switch only, if the pump is unplugged from the power source.

NOTICE

Keep a minimum distance of 2 in (5 cm) between the cooling fan and surrounding items (e.g., housing, walls, etc.), or else install an external automatic ventilation system.

Use connecting hoses with large diameter and keep them as short as possible to avoid flow losses. Locate the pump as closely as possible to the application.

Always install outlet tubing descending from the pump or provide other measures (e.g., install an oil mist separator at the outlet) to avoid backflow of condensate towards the pump.

Use a suitable valve to isolate the pump from the vacuum application. This is to allow the pump to warm up before pumping condensable vapors and to clean the pump after use before it is switched off.

When assembling, ensure **vacuum-tightness**. After assembly, check the whole system for leaks.

Secure hose connections at the pump appropriately, e.g.,

with hose clamps, to protect against accidental detachment.

During operation

DANGER

- ➔ Vent and dispose of **potentially dangerous gases or vapors** at the outlet of the pump appropriately.

WARNING

- ☞ Due to the high compression ratio, the pump might generate overpressure at the outlet. Check pressure compatibility with system components (e.g., exhaust tubing or exhaust valve) at the outlet. Ensure that the pump outlet is neither blocked nor restricted.

- ☞ **Maximum ambient temperature:** 104 °F (40 °C)
Check the maximum temperatures, if installing the pump in a cabinet or a housing. Make sure ventilation is adequate, especially if the ambient temperature is elevated.

CAUTION

- If the pump is installed at an altitude of more than 6500 ft (2000 m) above mean sea level, check compatibility with applicable safety requirements, and adopt suitable measures. There is a risk of the motor overheating due to insufficient cooling.
- Check compatibility with the **maximally permitted pressure** at outlet and the **maximum pressure difference** between inlet and outlet ports.
- Check the **oil level** of the rotary vane pump every time before starting the pump, however at least once a week. Check the oil level more frequently if high amounts of gas or vapor are pumped.
- If pumping aggressive, corrosive or otherwise dangerous gases and vapors, take appropriate measures to protect personnel, pump, and environment. Use ap-

appropriate equipment such as cold trap, separator, oil separator, full flow oil filter, shut-off valve (see “Accessories”, pg. 36) as well as special oil.

NOTICE

The **ambient temperature** should be at least 54°F (12 °C). Otherwise the pump may not start because of the high oil viscosity at low temperature.

Pumping down can be started at any pressure at the inlet **below atmospheric pressure**.

Do not start the pump, if the **pressure at the outlet port exceeds 16.0 psi (1.1 bar) absolute**.

Continuous operation is possible at any pressure below atmospheric pressure. For pumps RE/RZ 16 with oil mist separator, continuous operation is only possible below 75 Torr (100 mbar).

Oil consumption will increase at inlet pressures above 75 Torr (100 mbar). Check oil level more frequently.

Prevent internal condensation, transfer of liquids or dust. The pump unit will be damaged if liquids are pumped in significant amounts. Check the pump regularly for external soiling and deposits. Clean the pump if necessary to avoid an increase of the pump's operating temperature.

Single-phase motors are protected by a self-hold thermal cutout in the winding.

Three-phase motors are protected by a circuit-breaker isolating all poles in case of overload.

Note: Only a manual reset is possible. Switch off the pump and disconnect the electrical power cord. Identify and eliminate the cause of failure. Wait approximately five minutes before restarting the pump.

Avoid high heat supply (e.g., due to hot process gases). See “Technical data”, pg. 17, for maximum permitted gas and ambient temperatures.

A warm up period (approximately 30 min.) is required to ensure that the rated ultimate vacuum and pumping speed

and the full vapor pumping rate are attained.

Important notes regarding the use of gas ballast

Gas ballast is a continuous purge to keep the pump's interior as clean as possible and to reduce the possibility of condensation inside the pump.

! DANGER

➔ Air and pumped media might react inside the pump or at the outlet of the pump and form hazardous or explosive mixtures, when you use air rather than inert gas for the gas ballast. This constitutes a risk of significant damage to equipment and/or facilities, a risk of personal injury or even loss of life.

! WARNING

☞ Make sure that air/gas intake through the gas ballast valve can never lead to hazardous, explosive or otherwise dangerous mixtures. If in doubt, use inert gas.

NOTICE

To reduce condensation in the pump, do not pump vapor before the pump has reached its operating temperature. Open the gas ballast valve when pumping condensable vapors.

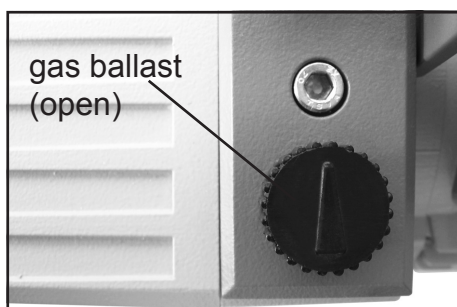

For **condensable vapors** (water vapor, solvents, etc.):

- Let the pump run **with gas ballast** to reduce condensation of pumped substances (water vapor, solvents, ...) in the pump or to decontaminate the pump oil from volatile substances.
- With gas ballast valve open, the ultimate vacuum will be reduced.
- Use inert gas for gas ballast to avoid the formation of explosive mixtures.
- To open and to close the gas ballast valve turn the gas

ballast valve cap or press the gas ballast switch at the terminal box (RE/RZ 16). The manual gas ballast valve is open if the arrow on the gas ballast cap is pointing towards the inlet of the pump (RE 2.5 / RZ 2.5 / RE 6 / RZ 6) or towards the labelling "GB" (RE 9 / RZ 9).

- Close the manual gas ballast valve by turning the cap 180°.

Operate the pump without gas ballast only in case of a clean vacuum system or when no condensable vapors can occur.

Shutdown & storage

NOTICE

Has the pump been exposed to condensate?

- Allow the pump to continue to run with an open gas ballast valve for a few minutes before switching off.

Long-term:

- Separate the pump from the application.
- Flush the pump with dry nitrogen.
- Carry out oil change (see "Oil change", pg. 32).
- Fill the pump completely with new oil (more than mark "max."!).

Attention: Before restarting the pump, drain oil to the maximum oil level (mark "max."!).

- Close the manual gas ballast valve.
- Close inlet and outlet ports (e.g., with transport caps or blind flanges).
- Store the pump under dry conditions.
- If necessary, carry out oil change and maintenance prior to use if the pump has been stored for longer than one year.

Oil change

DANGER

- ➔ Never operate the pump if parts of the pump are disassembled. Ensure that the pump cannot be operated accidentally.



- ➔ Before starting maintenance, isolate the pump from its application and disconnect the electrical power cord.
- ➔ **Note:** The pump or the pump oil might be contaminated with dangerous or corrosive process chemicals that have been pumped during operation. Adopt suitable decontamination measures if necessary. Take adequate precautions to protect people from the effects of dangerous substances if contamination has occurred. Ensure that the maintenance technician is familiar with the safety procedures which relate to the products processed by the pumping system.

WARNING

- ☞ Use appropriate protective clothing, safety goggles and protective gloves. Avoid inhalation and skin contact.

CAUTION

- Take adequate precautions when handling pump fluids, lubricants, and solvents. Use appropriate protective clothing, safety goggles and protective gloves to avoid excessive contact with the skin and possible skin irritations (including dermatitis).
Comply with all relevant statutory requirements and regulations concerning the handling, storage and disposal of oil.

NOTICE

Aging of the oil (as indicated by darker color compared to new oil, strange odor of the oil, particles in the oil, or contamination) necessitates an oil change.

Depending on the application (especially if corrosive gases or vapors have been pumped) it may be appropriate to check the oil frequently and to carry out an oil change, if necessary.

Under normal operating conditions:

- Check oil level every time before starting the pump.
- Carry out an oil change once aging of the oil is indicated by darker color compared to new oil.
- Carry out oil changes at least once a year.
- Dispose of the used oil, which may be contaminated, according to all applicable regulations.

Oil change procedure



- ☞ Carry out the oil change only after the pump has reached its normal operating temperature.
- ➔ Switch off the pump and isolate it from its application. Ventilate the pump to atmospheric pressure. Disconnect the electrical power cord.
- ☞ Choose a suitable pad; oil may drip. Use a suitable container to catch the oil.

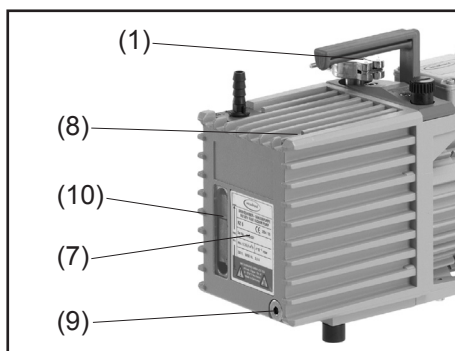

- ➔ Place a suitable container below the oil outlet (9).
- ➔ Remove the oil drain plug (9) below the rating plate, paying attention to the O-ring.
- ➔ Tilt the pump slightly and catch the oil in a suitable container.
- ☞ Dispose of the used oil according to regulations.
- ➔ Screw in oil drain plug (9) with O-ring.
- ➔ To flush the pump, pour in fresh oil (approx. 0.05 quarts (50 ml)) through the pump inlet (1) (remove separator if necessary).
- ➔ Operate the pump briefly. Drain flushing oil and repeat flushing procedure, if necessary, until all contaminations are flushed out.
- ➔ Remove the oil inlet plug (8). Fill in fresh oil through the oil inlet port until the oil level reaches the mark "max." (10). Do not overfill.
- ➔ Screw in oil inlet plug (8).

Notes on choosing the appropriate oil for the application

The **standard oil** for VACUUBRAND rotary vane pumps is the **B-oil**. This is a mineral oil, which is used for the first filling of the pump.

The advantages of the B-oil are: Flat viscosity curve, low vapor pressure, good chemical resistance, extended stability when pumping oxidants, acid or basic vapors compared to conventional mineral oils, and good skin compatibility.

Certain pumped media may attack the conventional oil in the pump. Special oils can be used preventively. It is at the users' responsibility to check if the materials of the wetted parts are resistant against the pumped substances. This is also mandatory if special oils are used.

Special oils:

Rotary vane pump oil K8

The rotary vane pump oil K8 is a special oil designed for pumping acid vapors. The oil is very hygroscopic and has a limited capacity for acids. With decreasing pH, the anticorrosive effect decreases as well, and it is necessary to change the oil at appropriate intervals. When the pump will stand still for prolonged periods (i.e., for several days), the oil must be drained and the pump must be filled with mineral oil.

Synthetic oil (perfluoropolyether oil, e.g., Fomblin®*)

Synthetic oils have an excellent chemical resistance and are certified for pumping pure oxygen. Therefore these oils are excellent for handling strong oxidants, e.g., halogens, nitrogen oxides, etc.

Attention: As perfluoropolyether oils mixed with mineral oils result in an emulsion, pumps used with these oils must be absolutely free of any residues of mineral oils. To accomplish this, you must completely disassemble and diligently clean the pump unit.

* reg. trade mark Montedison

Attention if using special oils: Due to a different viscosity / density compared to the standard oil, pumps filled with special oil may not achieve the specified ultimate pressure, or the pumps may not start reliably at temperatures below 54°F (12°C).

VACUUBRAND B-oil

1 liter (1.06 qt)	687010
5 liter (5.3 qt)	687011
20 liter (5.3 gal).....	687012
200 liter (52.8 gal).....	687013

Rotary vane pump oil K8

1 liter (1.06 qt)	687100
5 liter (5.3 qt)	687101
20 liter (5.3 gal).....	687102

Perfluoropolyether oil

500 ml (0.53 qt)	687600
------------------------	---------------

Accessories



Separator AK at the inlet for
 RE 2.5 / RZ 2.5 **698000**
 RE 6 / RZ 6 **698006**
 RE 9 / RZ 9 / RE 16 / RZ 16..... **698007**
 Protection of the pump against damaging liquid and solid substances, protection of the recipient against back flow of pump oil.



Oil mist separator FO at the outlet for
 RE 2.5 / RZ 2.5 / RE 6 / RZ 6 **698003**
 RE 9 / RZ 9 / RE 16 / RZ 16..... **698017**
 Protection of the environment against aerosols and oil mist, with integrated overpressure valve.



Full flow oil filter HF **698010**
 for RE 9 / RZ 9 / RE 16 / RZ 16
 Extending oil life.

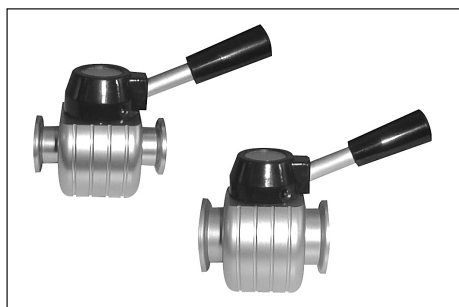

Butterfly valve
 VS 16 **665004**
 for RE 2.5 / RZ 2.5 / RE 6 / RZ 6
 VS 25 **665005**
 for RE 9 / RZ 9 / RE 16 / RZ 16

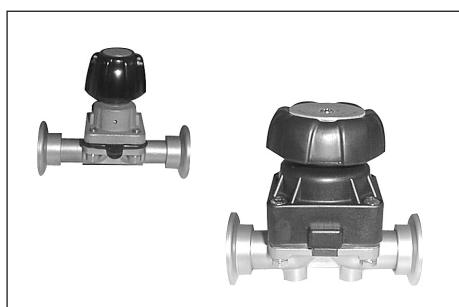

Diaphragm valve
 VM 16 for
 RE 2.5 / RZ 2.5 / RE 6 / RZ 6..... **664010**
 VM 25 for
 RE 9 / RZ 9 / RE 16 / RZ 16..... **664011**

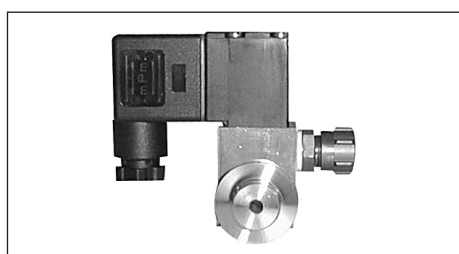

Solenoid operated gas ballast valve
 VB M KF DN 16..... **698005**
 for RE 2.5 / RZ 2.5 / RE 6 / RZ 6 / RE 9 / RZ 9



Glass cold trap GKF 1000i.....**667056**
at the inlet

Protection of the pump against aggressive substances, protection of the recipient against oil molecules.



Stainless steel cold trap

SKF H 25 at the inlet.....**667051**

SKF H 40 at the inlet.....**667053**

Protection of the pump against aggressive substances, protection of the recipient against oil molecules.

Oil return kit für R 2.5 / 6 / 9.....**698048**
for pumps with oil mist filter

Hose nozzle (for hoses with I.D. 3/8" (10 mm)), aluminum, DN 10,
for inlet of RE 2.5 / RZ 2.5 / RE 6 / RZ 6**662511**

Hose nipple, aluminum, for hoses DN 19 for
RE 2.5 / RZ 2.5 / RE 6 / RZ 6**662531**

Vacuum hose (rubber, DN 10).....**686002**

Vacuum hose (rubber, DN 20).....**686005**

Metal hose with KF DN 16

250 mm (9.8").....**673306**

500 mm (19.7").....**673316**

750 mm (29.5").....**673326**

1000 mm (39.4").....**673336**

Metal hose with KF DN 25

250 mm (9.8").....**673307**

500 mm (19.7").....**673317**

750 mm (29.5").....**673327**

1000 mm (39.4").....**673337**

PVC hose with internal spiral with KF DN 16

500 mm (19.7").....**686010**

1000 mm (39.4").....**686020**

PVC hose with internal spiral with KF DN 25

500 mm (19.7").....**686011**

1000 mm (39.4").....**686021**

PTFE vacuum hose (antistatic) with stainless steel small flanges. The inner side of the PTFE hose is smooth for increased chemical resistance, reduced deposits and high conductance

KF DN 16, 500 mm (19.7")	686030
KF DN 16, 1000 mm (39.4")	686031
KF DN 25, 500 mm (19.7")	686032
KF DN 25, 1000 mm (39.4")	686033

Vacuum gauge DCP 3000 with gauge head VSP 3000 (Pirani),

7.5*10 ² Torr - 1*10 ⁻³ Torr (1*10 ³ mbar - 1*10 ⁻³ mbar)	683190
100-230V 50/60 Hz	

Troubleshooting

Fault	Possible cause	Remedy
<input type="checkbox"/> Pump does not start.	<ul style="list-style-type: none"> ➔ Electrical power cord not plugged in, electrical supply failure? ➔ Supply voltage does not correspond with the pump (see rating plate)? ➔ Oil temperature below 54°F (12°C)? ➔ Pump unit contaminated? ➔ Motor thermally overloaded? ➔ Overpressure in outlet line? ➔ Oil mist filter clogged (filter element in contact with oil)? 	<ul style="list-style-type: none"> ✓ Plug in power cord. Check fuse. ✓ Connect pump to a suitable supply voltage. ✓ Operate the pump in suitable ambient conditions. ✓ Perform maintenance or clean the pump unit. ✓ Allow motor to cool down, identify and eliminate cause of failure. Manual reset is necessary. Switch off pump or unplug. Provide sufficient ventilation. ✓ Remove blockage in line, open valve. ✓ Drain oil, replace filter element if necessary.
<input type="checkbox"/> Pump does not achieve its ultimate vacuum or usual pumping speed.	<ul style="list-style-type: none"> ➔ Centring ring at small flange connection not correctly positioned, or leak in the pipeline or vacuum system? ➔ Long, narrow vacuum line? ➔ Oil contaminated (also with solvents)? ➔ Not enough oil? ➔ Measuring procedure or vacuum gauge not suitable for the application? ➔ Pump has not yet reached its operating temperature? 	<ul style="list-style-type: none"> ✓ Check pump directly - connect vacuum gauge directly at pump inlet - then check connection, pipeline and vacuum system if necessary. ✓ Use lines with larger diameter, length as short as possible. ✓ Change oil and flush with oil (see "Oil change"). ✓ Top up oil to correct level. ✓ Choose a suitable measuring procedure or vacuum gauge. ✓ Allow the pump to reach its operating temperature.

Fault	Possible cause	Remedy
<input type="checkbox"/> Pump does not achieve its ultimate vacuum or usual pumping speed.	<ul style="list-style-type: none"> ➔ Outgassing substances or vapor generated in the process? ➔ Inlet blocked? ➔ None of the above mentioned causes? 	<ul style="list-style-type: none"> ✓ Check process parameters. ✓ Open inlet. Ensure that the inlet line does not become blocked. ✓ Contact local distributor.
<input type="checkbox"/> Pump too noisy or strange noise.	<ul style="list-style-type: none"> ➔ Too much oil? ➔ Loud exhaust noise? ➔ None of the above mentioned causes? 	<ul style="list-style-type: none"> ✓ Lower oil level to mark "max." ✓ Connect a hose or assemble an oil mist filter at the outlet. ✓ Contact local distributor.
<input type="checkbox"/> Oil in the inlet line.	<ul style="list-style-type: none"> ➔ Back diffusion (small amount of oil, oil film)? ➔ Back streaming (large amount of oil)? 	<ul style="list-style-type: none"> ✓ Install a sorption trap or a separator, if necessary. ✓ Contact local distributor.
<input type="checkbox"/> Oil leakage.	<ul style="list-style-type: none"> ➔ Oil spilled? ➔ Other cause? 	<ul style="list-style-type: none"> ✓ Absorb the oil and dispose of according to regulations. ✓ Contact local distributor.
<input type="checkbox"/> High oil consumption.	<ul style="list-style-type: none"> ➔ High inlet pressure? ➔ Operation with gas ballast? ➔ Oil level too high? 	<ul style="list-style-type: none"> ✓ Normal. Top up oil whenever necessary. Install oil mist filter at outlet. ✓ Top up oil whenever necessary. Install oil mist filter at outlet. ✓ Lower oil level to mark "max."
<input type="checkbox"/> Fast aging of the oil.	<ul style="list-style-type: none"> ➔ Pumping aggressive gases? ➔ Condensation in the pump? 	<ul style="list-style-type: none"> ✓ Use suitable oil. ✓ Use separator or cold trap.

➔ A service manual with exploded view drawings, spare parts list and directions for repair is available on request.

👉 The service manual is intended for trained service people only.

Notes on return to the factory

Repair - return - DAkkS calibration

NOTICE

Safety and health of our staff, laws and regulations regarding the handling of dangerous goods, occupational health and safety regulations and regulations regarding safe disposal of waste require that for all pumps and other products, the “Health and safety clearance form”, pg. 45, must be sent to our office fully completed and signed before any equipment is shipped to the authorized service center.

Fax or mail a completed copy of the health and safety clearance form to us in advance. The declaration must arrive before the equipment. **Enclose a second completed copy with the product.** If the equipment is contaminated, you must notify the carrier.

No repair / DAkkS calibration is possible unless the correctly completed form is returned. Inevitably, there will be a delay in processing the equipment if information is missing, or if this procedure is not followed.

CAUTION

If the product has come in contact with chemicals, radioactive substances or other substances dangerous to health or environment, the product must be decontaminated **prior to sending it back to the service center.**

- Return the product to us disassembled and cleaned and accompanied by a certificate verifying decontamination or
- Contact an industrial cleaning and **decontamination service** directly or
- Authorize us to send the product to an industrial cleaning facility **at your expense.**

To expedite repair and to reduce costs, please enclose a detailed description of the problem and the product's operating conditions with every product returned for repair.

We submit **repair quotations** only on request and always at the customer's expense. If an order is placed, the costs incurred for problem diagnosis are offset from the costs for repair or from the purchase price, if the customer prefers to buy a new product instead of repairing the defective one.

- **If you do not wish a repair on the basis of our quotation, the equipment may be returned to you disassembled and at your expense.**

In many cases, the **components must be cleaned in the factory** prior to repair.

For cleaning we use an environmentally friendly water-based process. Unfortunately the combined attack of elevated temperature, cleaning agent, ultrasonic treatment and mechanical stress (from pressurized water) may result in damage to the paint. Please mark in the health and safety clearance form, if you wish a **repaint at your expense** just in case such a damage should occur.

We will also replace parts for cosmetic reasons at your request and at your expense.

NOTICE

Before returning the equipment, ensure that (if applicable):

- Oil has been drained and an adequate quantity of fresh oil has been filled in to protect against corrosion.
- Equipment has been cleaned and/or decontaminated.
- All inlet and outlet ports have been sealed.
- Equipment has been properly packed, (if necessary, please order original packaging materials at your cost), marked appropriately and the carrier has been notified of any possible contamination.
- The completed health and safety clearance form is enclosed.

We thank you in advance for your understanding of the necessity for these measures that protect our employees, and ensure that your pump is protected in shipment.

Scrapping and waste disposal:

Dispose of the equipment and any components removed from it safely in accordance with all local and national safety and environmental requirements. Particular care must be taken with components and waste oil which have been contaminated with dangerous substances from your processes. Do not incinerate fluoroelastomer seals and O-rings.

- You may authorize us to dispose of the equipment **at your expense.**

Warranty

VACUUBRAND shall be liable for insuring that this product, including any agreed installation, has been free of defects at the time of the transfer of risk.

VACUUBRAND shall not be liable for the consequences of improper handling, use, servicing or operation of this product or the consequences of normal wear and tear of wearing parts such as diaphragms, seals, valves, vanes, condensers, oil and the breakage of glass or ceramic parts, for the consequences of chemical, electrochemical or electrical influences or the failure to follow the instructions in this manual.

Claims for defects against VACUUBRAND shall be limited to one year from delivery. The same shall apply to claims for damages irrespective of legal grounds.

For further information on general terms and conditions refer to www.vacuubrand.com.

Health and safety clearance form



Devices will not be accepted for any handling before we have received this declaration.
Please read and comply with "Notes on return to the factory".
Oil filled pumps: Drain oil prior to shipping absolutely!

1. Device (Model): 2. Serial no.:

3. Reason for return / malfunction:

.....

4. Has the device been used in a copper process step (e.g., semiconductor production).

yes no

5. Substances (gases, liquids, solids) in contact with the device / which have been pumped:

.....

.....

.....

6. Prior to return to the factory the device has been decontaminated.

yes no

Description of the decontamination method and the test / verification procedure:

.....

.....

7. The device is free of hazardous, harmful substances.

yes no

8. Protective measures required for VACUUBRAND employees:

.....

9. If the paint is damaged, we wish a repaint or a replacement of parts for reason of appearance (repaint and replacement at customer's expense).

yes no

10. Legally binding declaration

We assure for the returned device that all substances, which have been in contact with the device are listed in section 5 and that the information is complete and that we have not withheld any information. We declare that all measures - where applicable - have been taken listed in section "Return to the factory". By our signature below, we acknowledge that we accept liability for any damage caused by providing incomplete or incorrect information and that we shall indemnify VACUUBRAND from any claims as regards damages from third parties. We are aware that as expressed in § 823 BGB (Public Law Code of Germany) we are directly liable for injuries or damages suffered by third parties, particularly VACUUBRAND employees occupied with handling/repairing the product.
Shipping of the device must take place according to regulations.

Name: Signature:

Job title: Company's seal:

Date:

Release for repair grant by VACUUBRAND (date / signature):

VACUUBRAND GMBH + CO KG
Alfred-Zippe-Straße 4
97877 Wertheim, Germany

Tel.: +49 9342 808-5660
Fax: +49 9342 808-5666
E-Mail: service@vacuubrand.com
www.vacuubrand.com



EG-Konformitätserklärung für Maschinen
EC Declaration of Conformity of the Machinery
Déclaration CE de conformité des machines

Hersteller / Manufacturer / Fabricant:

VACUUBRAND GMBH + CO KG · Alfred-Zippe-Str. 4 · 97877 Wertheim · Germany

Hiermit erklärt der Hersteller, dass die Maschine konform ist mit den Bestimmungen der Richtlinie 2006/42/EG.

Hereby the manufacturer declares that the machinery is in conformity with the directive 2006/42/EC.

Par la présente, le fabricant déclare, que la machine est conforme à directive 2006/42/CE.

Drehschieberpumpe / Rotary vane pump / Pompe à palettes:

Typ / Type / Type: RE 2.5 / RZ 2.5 / RE 6 / RZ 6 / RE 9 / RZ 9 / RE 16 / RZ 16

Artikelnummer / Order number / Numéro d'article: 697150, 697151, 697152, 697156 / 698120, 698121, 698122, 698126, 2614197, 2614514, 2615111 / 697160, 697161, 697162, 697166 / 698130, 698131, 698132, 698135, 698136 / 697170 / 698140, 698141, 698142, 698145 / 697080, 697086, 697087 / 698050, 698056, 698057, 698052

Seriennummer / Serial number / Numéro de série: Siehe Typenschild / See rating plate / Voir plaque signalétique

Die Maschine ist konform mit weiteren Richtlinien / The machinery is in conformity with other directives / La machine est conforme à d'autres directives:

2006/95/EG, 2004/108/EG, 2011/65/EU

Angewandte harmonisierte Normen / Harmonized standards applied / Normes harmonisées utilisées:

DIN EN ISO 12100:2011, DIN EN IEC 61010-1:2010 (Ed. 3), DIN EN 1012-2:2011, DIN EN 61326-1:2006, DIN EN 50581:2013

Bevollmächtigter für die Zusammenstellung der technischen Unterlagen / Person authorised to compile the technical file / Personne autorisée à constituer le dossier technique:

Dr. J. Dirscherl · VACUUBRAND GMBH + CO KG · Alfred-Zippe-Str. 4 · 97877 Wertheim · Germany

Wertheim, 20.11.2013

Ort, Datum / place, date / lieu, date

(Dr. F. Gitmans)

Geschäftsführer / Managing director / Gérant

ppa.

(Dr. J. Dirscherl)

Technischer Leiter / Technical Director / Directeur technique



VACUUBRAND GMBH + CO KG

Alfred-Zippe-Str. 4 · 97877 Wertheim

T +49 9342 808-0 · F +49 9342 808-5555

info@vacuubrand.com

www.vacuubrand.com

Certificate



Certificate no.

CU 72132401 01

License Holder:

VACUUBRAND GMBH + Co. KG
 Alfred-Zippe-Str. 4
 97877 Wertheim
 Germany

Manufacturing Plant:

VACUUBRAND GMBH + Co. KG
 Alfred-Zippe-Str. 4
 97877 Wertheim
 Germany

Test report no.: USA-VS 31381858 001

Client Reference: M. von Przychowski

Tested to:

UL 61010-1:2012
 CAN/CSA-C22.2 NO. 61010-1-12

Certified Product: Rotary Vane Vacuum Pump for Laboratory Use **License Fee - Units**

Model Designation: RE 2.5; RZ 2.5

7

Rated Voltage:

- 1) AC 230V, 50/60Hz or
- 2) AC 120V, 60Hz or
- 3) AC 100-115V, 50/60Hz; AC 120V, 60Hz
 AC 200-230V, 50/60Hz

Rated Current:

- 1) 1.6A, 2) 3.0A
- 3) 4.0A; 2.6A; 2.0A

Protection Class: I

7

Appendix: 1, 1-3

Licensed Test mark:**Date of Issue**

(day/mo/yr)

05/09/2013

Certificate



Certificate no.

CU 72132401 02

License Holder:

VACUUBRAND GMBH + Co. KG
 Alfred-Zippe-Str. 4
 97877 Wertheim
 Germany

Manufacturing Plant:

VACUUBRAND GMBH + Co. KG
 Alfred-Zippe-Str. 4
 97877 Wertheim
 Germany

Test report no.: USA-VS 31381858 001

Client Reference: M. von Przychowski

Tested to:

UL 61010-1:2012
 CAN/CSA-C22.2 NO. 61010-1-12

Certified Product: Rotary Vane Vacuum Pump for Laboratory Use

License Fee - Units

Model Designation: RE 6; RZ 6

Rated Voltage:

- 1) AC 230V, 50/60Hz or
- 2) AC 120V, 60Hz or
- 3) AC 100-120V, 50/60Hz
 AC 200-230V, 50/60Hz

Rated Current:

- 1) 2.5A, 2) 4.6A
- 3) 5.4A; 2.7A

Protection Class: I

Licensed Test mark:



Date of Issue

(day/mo/yr)

05/09/2013

Disclaimer: Our technical literature is only intended to inform our customer. The validity for specific applications of general empirical values and results obtained under test conditions depends on a number of factors beyond our control. It is therefore strictly the users' responsibility to very carefully check the validity of application to their specific requirements. No claims arising from the information provided in this literature will, consequently, be entertained.



Alfred-Zippe-Str. 4 · 97877 Wertheim / Germany
T +49 9342 808-0 · F +49 9342 808-5555
info@vacuubrand.com · www.vacuubrand.com

VACUUBRAND GMBH + CO KG
- Technology for Vacuum Systems -
© 2013 VACUUBRAND GMBH + CO KG Printed in Germany