

SK00-4330-DI-002-01

No. 030402

ULVAC

INSTRUCTION MANUAL

OIL SEALED ROTARY VACUUM PUMP

MODEL

PKS-016

PKS-030

PKS-070

Read this manual before operation and keep it at your hand for immediate reference

Components division
ULVAC, Inc.

CAUTION:

Subjecting this pump to low temperatures (below 4) may cause water pipes and/or jackets to burst.

If a pump is located outside and subjected to freezing temperatures, disconnect the water inlet from its water supply. Cooling water in the water pipe and/or jackets should be blown out by compressed air.

Failure to do so may cause the water to freeze, and damage to the water pipe and/or jackets may result.

Table of Contents

1. Inspection	4
2. Mounting	5
3. Oil filling	5
4. Electrical connections	6
5. Fitting and detaching of V-belts	7
6. Vacuum system connection	8
7. Gas ballast valve	10
8. Operation	10
9. Ultimate pressure	12
10. Periodical checking	13
11. Oil replacement	13
12. Vacuum pump oil for low temperatures	14
13. Major expendable parts	15
14. Pump oil characteristics table	16

SERVICE CENTER

INTRODUCTION

The ULVAC-PKS Series pumps are suitable for industrial use in medium or high vacuum pumping systems.

The PKS Series are self-contained rotary, oil sealed piston type units, and are designed for the best possible stability and small floor space, and have well proven reliability. We recommend that you use "ULVOIL-R-7" rotary pump oil specified by ULVAC for best results. However, any good quality mechanical vacuum pump oil is suitable with the PKS Series, although we do suggest that you consult with a vacuum specialist first.

SPECIFICATIONS FOR THE PKS

Model \ Description	PKS-016	PKS-030	PKS-070
Displacement [L/min]	1600	3000	7000
*Ultimate Pressure [Pa]	6.7×10^{-1}	6.7×10^{-1}	6.7×10^{-1}
Ultimate Pressure with gas-ballast [Pa]	6.7×10^1	6.7×10^1	6.7×10^1
Power required [kW]	2.2 [4-poles]	3.7 [4-poles]	11 [6-poles]
Pump revolution [RPM]	425	400	400
Max. water vapor pumping rate [kg/hr]	2.4	5	9
Oil required [L]	6.5	8	20
Cooling water required [L/min]	---	3	5
Weight (without motor) [kg]	225	380	900

* "Ultimate pressure" is measured by "McLeod Gauge".

1. Inspection

When unpacking, check the following items,

- 1) Is the pump received of the exact model you have ordered?
- 2) Are the complete accessories present?
 - 2-1) In case you have ordered a motor-less pump, the following items should be present in the pack:
 - 2-1): Motor-less Pump
 1. Pump
 2. Pump-base
(Type: PKS-016 only)
 3. V-belts
 4. Belt-cover
 5. Pulley-cover
 6. Motor-Pulley
 7. Anchor-bolts
 8. Pump oil
 - 2-2) In case you have ordered a pump, with motor, the following items should be present in the pack:
 - 2-2): Pump with Motor
 1. Pump
 2. Pump-base
(Type PKS-016 only)
 3. V-belts
 4. Belt-cover
 5. Pulley-cover
 6. Motor-Pulley
 7. Anchor-bolts
 8. Motor
 9. Pump oil
- 3) Visually inspect if there is any damage to the pump and the parts caused by transportation.
- 4) Check for any looseness of screws or nuts, or for any disconnection of parts.

Note: Should you have noticed any trouble or damage with the pump or its accessories, please immediately notify our distributor or contact ULVAC's International Department directly.

2. Mounting

- 1) Set the PKS as near as possible to the vacuum equipment, insuring that water and exhaust connections can be conveniently made.
- 2) The PKS should be mounted on a rigid foundation such as a concrete floor, and made level by shimming or grouting if necessary, and bolted in place.

[Refer to Fig. 7, 8, 9]

Note: Excessive environmental dust, acid fumes, solvent vapor etc., should be avoided.

3. Oil Filling

[Refer to Fig. 7, 8, 9]

- 1) Remove the “Oil-Filler Cap” (See Fig. 4 ~ 6) and make sure that the “Oil Drain Valve” is closed.
- 2) Fill the pump with ULVAC's specified oil (ULVOIL-R-7) until the oil level can be observed at the oil level window attached to the side of the pump. (See Fig. 4 ~ 6)

The optimum level is 5 mm above the lower line of the window glass while the pump is running. This level will change slightly after the first few hours of use. In most cases oil should be added after operating the pump for a short while.

Note: If the amount of oil contained in the pump is not appropriate, the performance of the pump will be unsatisfactory.

3) Pour oil into the Oilers. (See Fig. 4 ~ 6)

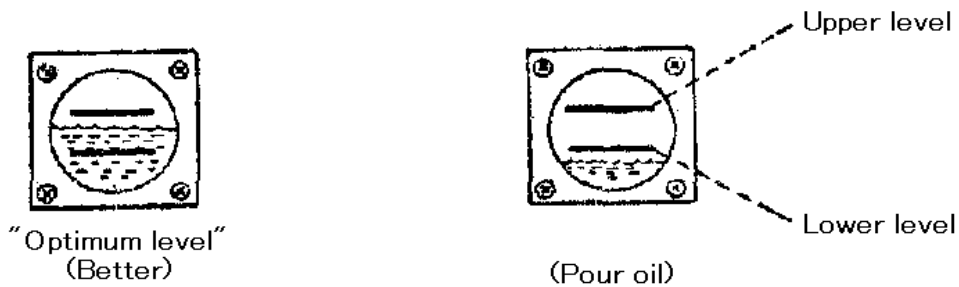

Oil level windows

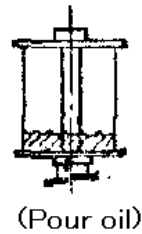

Oiler

4. Electrical Connections

Make all electrical connections in accordance with the following procedures.

- 1) Connect the power lines to the motor terminals before fitting the belts.
- 2) Check the fuses at the terminal. The fuses should be rated at the value shown in the following table.

Type	Motor	Fuse
PKS-016	2.2 kW (4P)	20A
PKS-030	3.7kW (4P)	30A
PKS-070	11kW (6P)	100A

- 3) Connect "oil feeding-solenoid valve" to the pump line to interlock with the pump. (Refer to Fig. 1)

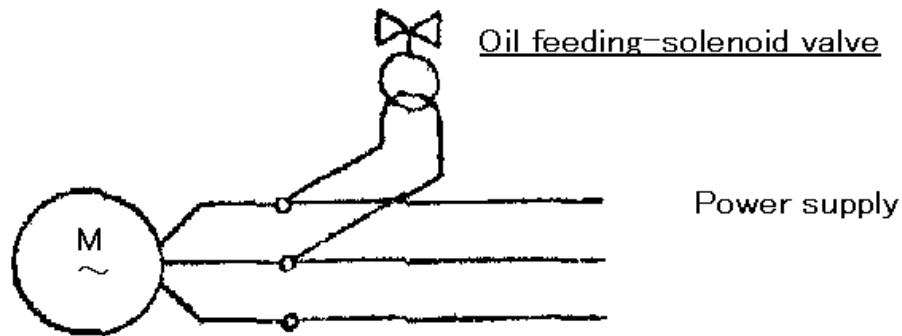



Fig. 1. Standard electrical connection

Note: Separate wiring will eventually be required if you use a motor rated at different line voltage and cycle from those for the solenoid. Make sure the proper voltage and current are supplied to both the motor and the solenoid coil. Both may fail to operate if the voltage is less than 90% or more than 110% of that rated.

- 4) Activate the motor and observe the direction of rotation of the motor pulley.
- 5) An arrow SYMBOL [like this: ] is put on the belt-cover to indicate the correct rotation direction. If the pump does not rotate in the right direction, interchange any two of the three-phase leads.
- 6) Fit V-belts.

5. Fitting and Adjusting the V-belts

- 1) Never touch the V-belts while the pump is running.
- 2) At approximately the center of the span, between motor pulley and the pump, apply 4 to 5 pounds of pressure on the V-belts by hand. If the tension is correct, the resulting deflection should be about 1.5 cm (~ 1/2").

- 3) The belt becomes slightly longer after it has been used. Adjust the tension of the belt once a week after the Start of operation.
- 4) The adjustment of the belt-tension should be made by shifting the motor base. Tighten adjusting nuts or bolts securely after such adjustments.

Caution: Maintenance of proper belt tension is important.

Too tight or loose adjustment is harmful to the shaft-bearings. Too loose an adjustment allows the belt-to slip and shorten the life-time of the belt.

6. Vacuum System Connection

- 1) Be sure that the inside of the vacuum equipment, i.e., pipes and vacuum valves, are clean and free from excessive moisture or liquid, chips, rust, dust, etc. before you connect the system with the PKS pump.

Caution: Mechanical trouble will result if the pump breaths metal chips or visible dust. Also, if the pump evacuates excessive moisture, both the guaranteed ultimate pressure and the pump's internal mechanism will be effected. Excessive moisture may cause internal corrosion.

- 2) It is recommendable to install a vacuum valve [A] between the equipment and the pump. (See Fig. 2)

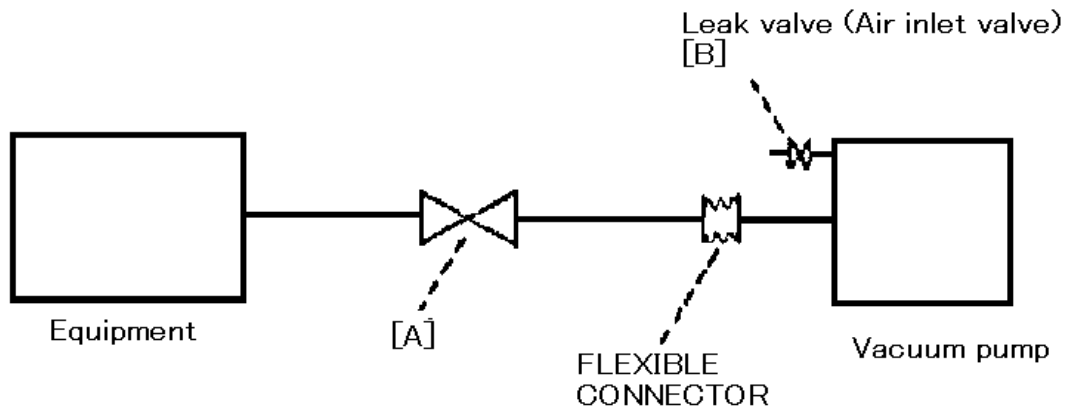

[Fig. 2]

Standard vacuum system piping for PKS

When the pump stops, close vacuum valve [A] to keep the equipment under vacuum, then open leak valve [B] to vent the pump, thus preventing oil counter-flow within the pump.

- 3) It is advisable to install a metallic flexible connection between the pump intake and vacuum piping to eliminate vibration.

Caution: A wire net (i.e., suction filter) is provided within the pump intake to prevent larger solids from entering the pump. Please do not remove this wire mesh.

Note: This net should be cleaned periodically according to your specific maintenance schedule.

7. Gas-Ballast Valve

A gas ballast valve is provided on the side of the PKS. (Ref. DWG. Fig. 4 ~ 6)

When condensable gases such as steam or solvents, etc. are pumped, compressed gases may be condensed and mixed into the pump oil.

Such gases circulate inside the pump and may effect both the ultimate pressure and also shorten the life of the pump's shaft seals and bearings. Consequently the life of the pump itself will be shortened. But in this pump, when a condensable gas is pumped, such a gas can be discharged out of the pump through the exhaust valve without condensing it into the pump oil, by opening the gas ballast valve after the pump temperature increases sufficiently. (When gases other than condensable gases are pumped, operate the pump with the gas ballast valve closed).

8. Operation

8.1 Pump start

Recheck the prescribed installation once more. Operate the pump in accordance with the following procedures to obtain the best performance of the pump.

- 1) Close the vacuum valve [A] (as shown in Fig. 2) and open the leak valve [B].
- 2) Turn the motor-switch on.
- 3) Close the leak valve [B] when the pump is rotating at a constant speed.
- 4) Check the oil-feeding solenoid valve for proper operation.

Note: If the pump does not rotate smoothly, do the following;

- 1) Check the power supply
- 2) Check the charged oil level. If the problem still persists, contact ULVAC or ULVAC's distributor.

- 5) When the pump is kept running for several hours, the oil temperature in the case will be rise to about 70 °C at a room temperature of 20 °C . If the oil temperature exceed 70 °C when the gas ballast valve is kept closed, some trouble might be suspected. Please stop the pump and contact ULVAC or ULVAC's distributor at once.
- 6) If the pump does not start rotating, the pump cylinder might be filled with oil. Open the leak valve to attempt to correct this problem.

8.2 Pump stop

- 1) Close vacuum valve [A].
- 2) Stop the motor and vent the pump. Open the leak-valve [B].

Note: Make sure the leak valve is opened when the pump is stopped or, in the case of a power failure, prevent the pump and vacuum system from flooding with oil.

Note: Oil circulation

Pump oil will be introduced into the filter case through the oil-feeding solenoid valve.

- 1) PKS-016 oil-flow check.

Remove the filter body cap, Observe the oil-flow [See Fig.4]

- 2) PKS-030 or PKS-070 oil-flow check.

Observe the oil filter window. [See Fig. 5 ~ 6]

Note: Cooling water connection

- 1) The PKS-016 pump is air-cooled.
- 2) The PKS-030 or PKS-070 pump is water-cooled, so you must connect the pump to a water supply. (Ref. Fig. 3)

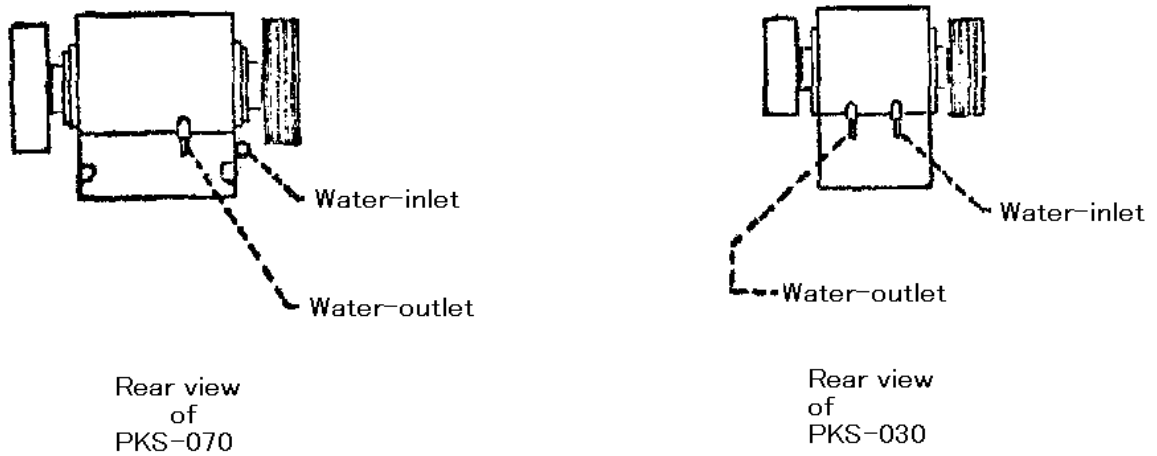

[Fig. 3]

9. Ultimate Pressure

"Ultimate Pressure" refers to the lowest attainable pressure of the pump. Therefore, this pressure should be measured under the most favorable conditions. It should be measured, using new pump oil, by means of a vacuum gauge installed at the inlet of the pump; the rest of the vacuum system should be functionally disconnected from the pump.

The measured values of the ultimate pressure of the rotary vacuum pump may slightly depend upon the kind of vacuum gauge used. According to the "Japan Industrial Standard" [JIS] "ultimate pressure" is determined by means of a McLeod gauge which is capable of measuring the partial pressure of air only.

If the ultimate pressure is measured without disconnecting the vacuum equipment, the observed pressure may be higher than the specified ultimate pressure of the pump due to the influence of the vapor or various kinds of gas produced from water condensation or rust adhering to the inner wall of the equipment. If any other gauge except McLeod gauge is used, the above-mentioned difference may be very larger.

10. Periodical Checking

Check the following points periodically.

- 1) Check for looseness of bolts and nuts.
- 2) Check to see if the gas-ballast valve is properly operating.
- 3) Check the wire net on the inlet port and clean it.
- 4) Check the oil amount circulating and the degree of contamination through the transparent glass on the filter lid. (in case of Type PKS-016: See the oil level gauge)

Replace the vacuum pump oil periodically. It is advisable to replace the oil 2 ~ 3 times a year.

11. Oil replacement

It might be necessary to exchange oil when the ultimate pressure of the pump itself is higher or the oil becomes too dirty. It is often the case where the ultimate pressure is not attainable simply because the pump oil is too old. It is most important to replace the pump oil if any condensable gases have been pumped or if any sludge is present on the bottom of the oil basin. If sludge is present, it is necessary to wash it out by repetitive oil changes. Please replace oil in accordance with the following procedures.

- 1) Open the drain-valve and drain most of the oil. Activate the pump for 3 ~ 5 seconds. This will cause the remaining to be completely drained.
- 2) Close the drain plug and fill new oil from the suction pipe.(means inlet)

After running for a minute, drain the oil in the same way as the above step.

- 3) Repeat steps 1) ~ 2) several times. The pump will be almost clean
- 4) Finally, close the drain valve and fill the specified amount of new oil.

12. Vacuum Pump Oil for Low Temperature

The specified oil is ULVOIL-R-7. In low temperatures (below about 10 °C) may experience difficulty with starting the pump. Therefore, check the following points carefully; belt tension, motor fuse, smoothness of rotation. If the pump still can not be started easily, despite normal behavior the above check points, try using ULVOIL-R-4 oil.

Caution: In high temperature (above about 10 °C) , (ULVOIL-R-7) oil should be used.

13. Major Expendable Parts (Parts No.: See Fig.-9, 10)

Model1: PKS-016 (Parts No.: See Fig. 10)

Parts No.	Description		Q'ty
(18)	Bearing	No.6307	2
(24)	Oil-seal	VC-40625	2
(23)	Oil-seal	SC-406212	2
(25)	Oil-seal	SC-355511	1
(11)	O-ring	JISB-2401 G-75	2
(8)	O-ring	JISB-2401 G-105	2

Model2: PKS-030 (Parts No.: See Fig. 11)

Parts No.	Description		Q'ty
(22)	Bearing	No.6410	2
(25)	Oil-seal	VC-65885	2
(26)	Oil-seal	SC-658812	2
(27)	Oil-seal	TC-478012	2
(21A)	O-ring	JISB-2401 P-50	2
(12A)	O-ring	JISB-2401 G-130	1

Model3: PKS-070 (Parts No.: See Fig. 12)

Parts No.	Description		Q'ty
(19)	Bearing	No.21313	2
(22)	Oil-seal	VC-70955	1
(23)	Oil-seal	SC-709513 (Vacuum tight type)	1
(25)	Oil-seal	VC-65886	1
(26)	Oil-seal	SC-658812 (Vacuum tight type)	1
(24)	Oil-seal	TC-658812	2
(13)	O-ring	AN 6230-31	2

14. Pump Oil Characteristics Table

(Table-1) shows the characteristics of pump oils. If you could not get the specified oil ULVOIL-R-7, you may use another kind of pump oil having almost the same characteristics as (Table-1).

ROTARY VACUUM PUMP OIL

[Table - 1]

OIL	ULVOIL-R-4	ULVOIL-R-7
Component (%)	Saturated Hydrocarbon 85 Unsaturated Hydrocarbon 15	Saturated Hydrocarbon 85 Unsaturated Hydrocarbon 15
Molecular weight	400 ~ 420	450 ~ 470
Specific Gravity at 15	0.89	0.89
Viscosity (Centi stokes)	40 ~ 50 5 ~ 7	65 ~ 75 7 ~ 9
Viscosity (Redwood second)	50 >50	170 ~ 180 > 60
Pour Point ()	-15	-15
Fire Point ()	> 210	> 210
Acid Value (mg KOH/gr)	< 0.01	< 0.01
Residual Carbon (%)	< 0.05	< 0.1
Vaporized Component 98 x 5hr (%)	< 0.03	< 0.02
Vapour Pressure (Torr)	< 1 X 10 ⁻⁴	< 1 X 10 ⁻⁵

SET					
SUB No. 子番号	SYM 記号	DESCRIPTION 名称	DRAWING No. 图番	MATERIAL 材質	REMARKS 備考

OUTLINE DRAWING
OIL SEALED ROTARY VACUUM PUMP
MODEL PKS-0162

Fig. 4

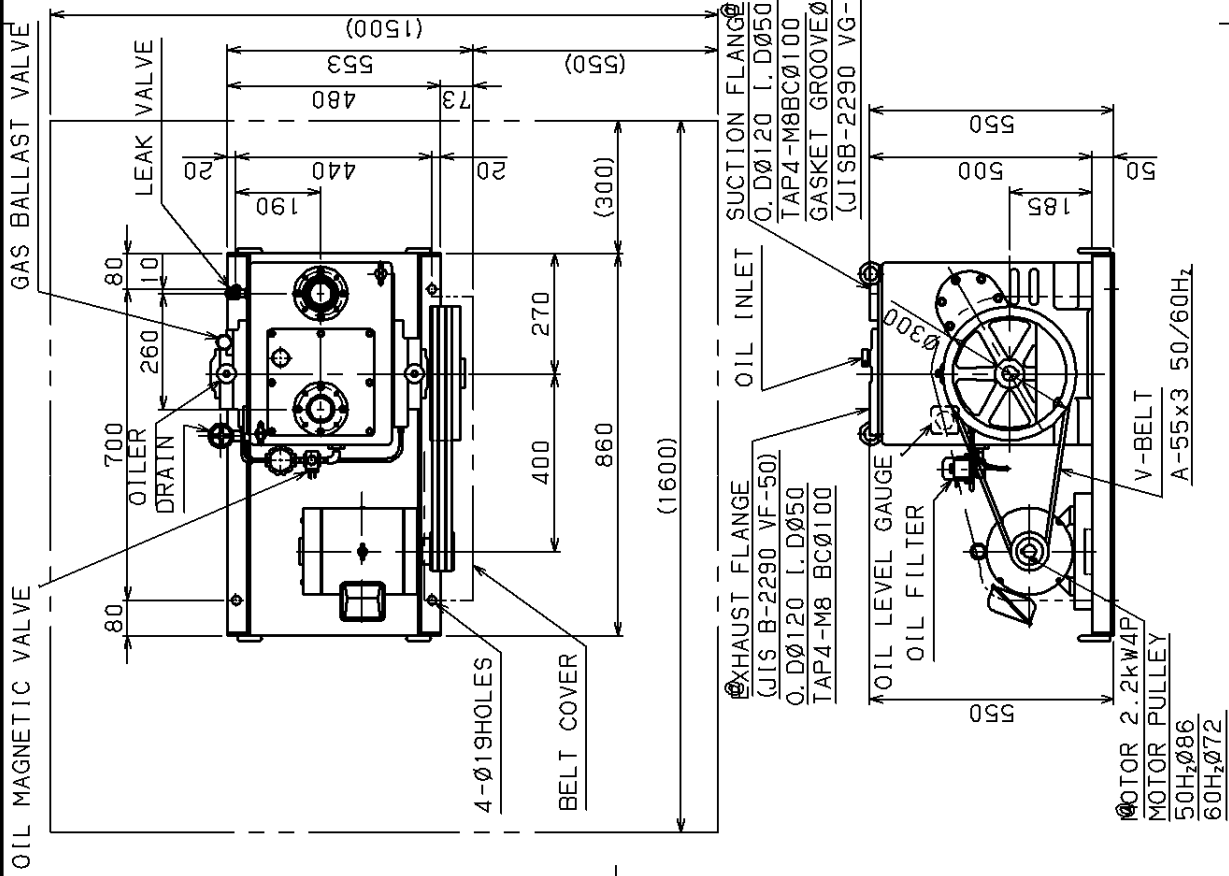

W. T. 2.25kg (WITHOUT MOTOR)

M No.					
TOLERANCES UNLESS NOTED	JIS B 0405-	第 A3	MARK	DATE	REVISION
APPRV 承認	CHECK 検閲	DESIG 設計	DRAW 製図	REMARKS	
				TITLE MODEL PKS-0162	
				OUTLINE DRAWING	
			谷中	SCALE 1/10	
				DATE 96.01.24	
MFG No.				DWG No.	KA6001-012-02A /

SET									
SIDE No. 侧号	QTY 数量	SYM 符号	DESCRIPTION 名称	DRAWING No. 图号	MATERIAL 材质	REMARKS 备注			

OUTLINE DRAWING
OIL SEALED ROTARY VACUUM PUMP
MODEL PKS-0304

Fig. 5

W. T. 380kg (WITHOUT MOTOR)

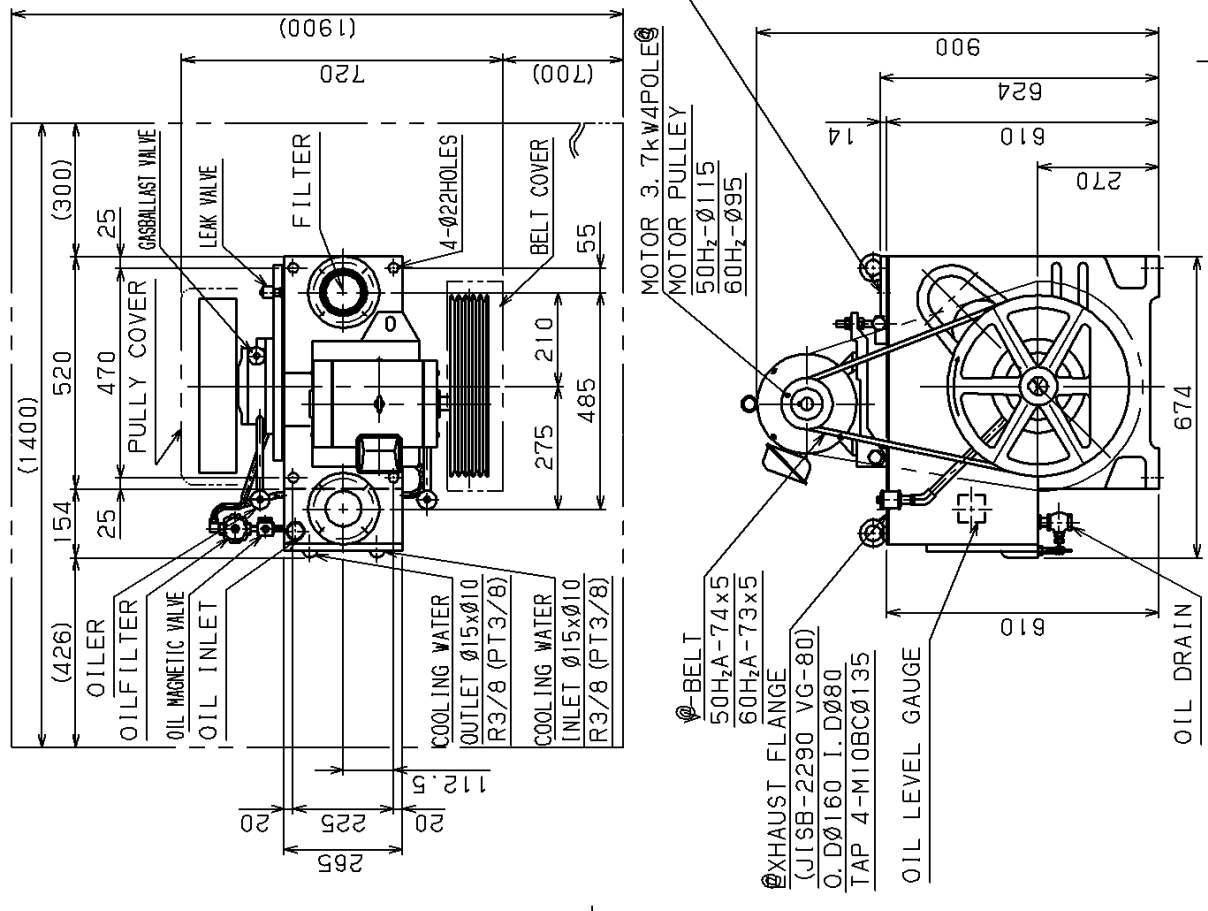

SUCTION FLANGE
 (JISB-2290 VG-80)
 O. D Ø160 I. D Ø80
 TAP 4-M10BCØ135
 GASKET GROOVE Ø110xØ100x3

M									
No.									
TOLERANCES UNLESS NOTED ±	JIS B 0405-	A3	MARK	DATE	REVISION	REMARKS			
APPRV 承認	CHECK 校核	DESIG 設計	DRAW 製図	SCALE 1/10	DATE 96.01.24	TITLE MODEL PKS-0304			
						OUTLINE DRAWING			
						OIL SEALED ROTARY VACUUM PUMP			
MFG No.						DWG No. KA6100-012-02A /			

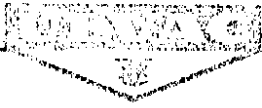

FOUNDATION DRAWING

TYPE PKS-0162

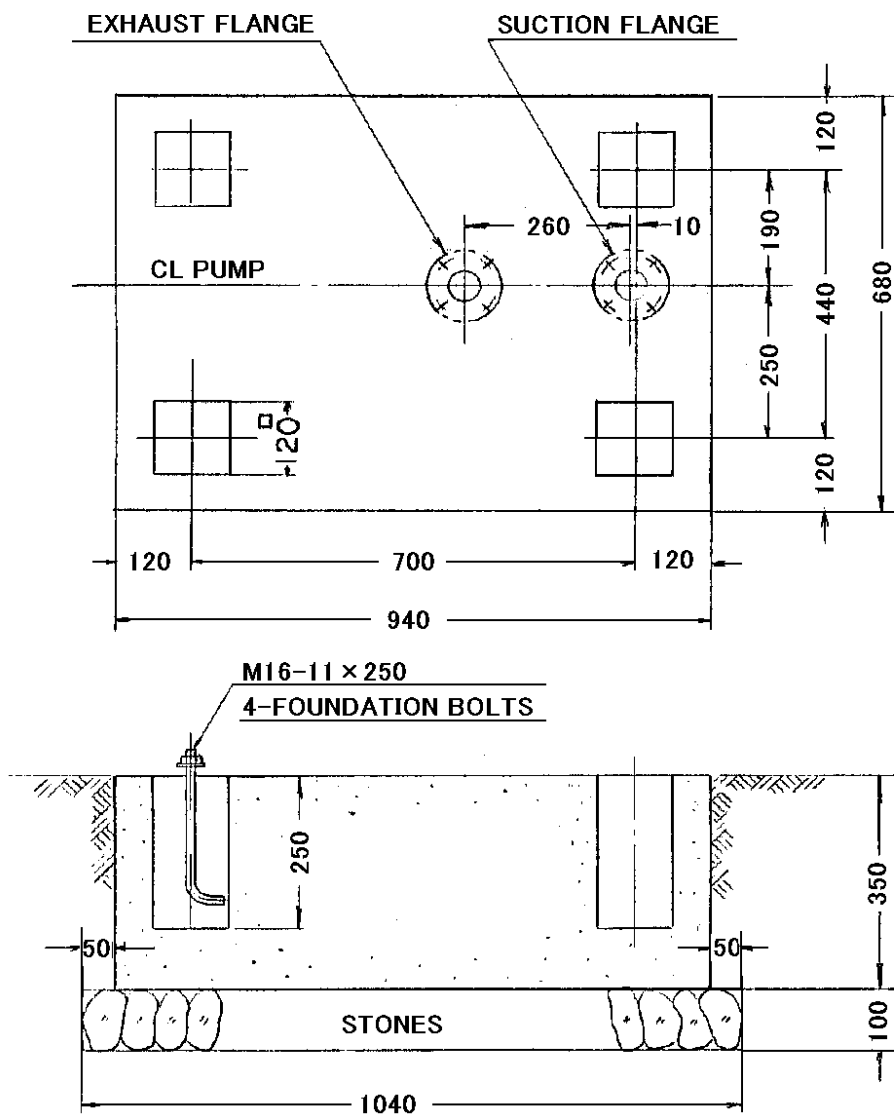
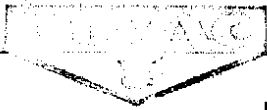

Fig. 7



FOUNDATION DRAWING
TYPE PKS-0304

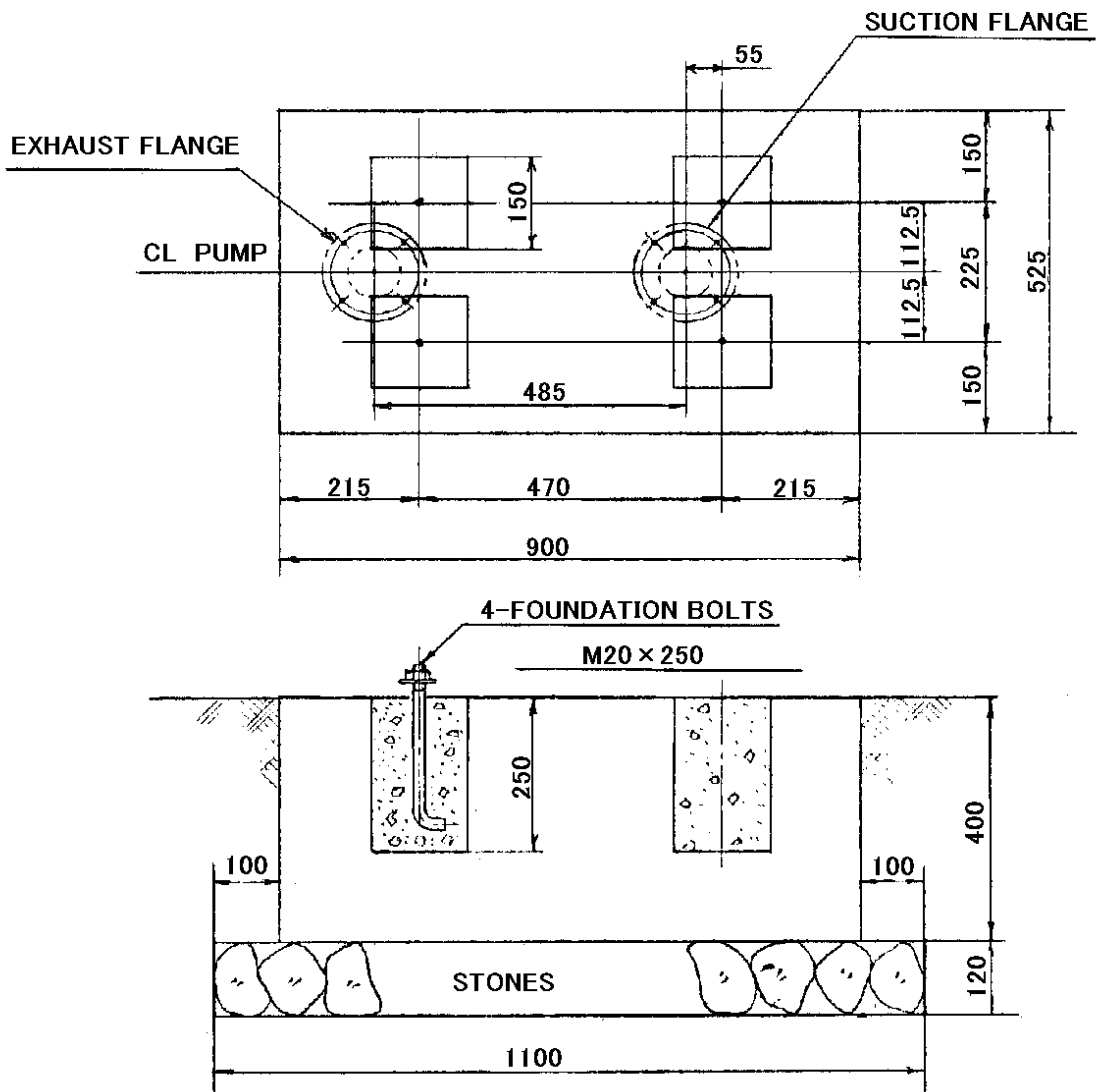

Fig. 8



FOUNDATION DRAWING

TYPE PKS-0701

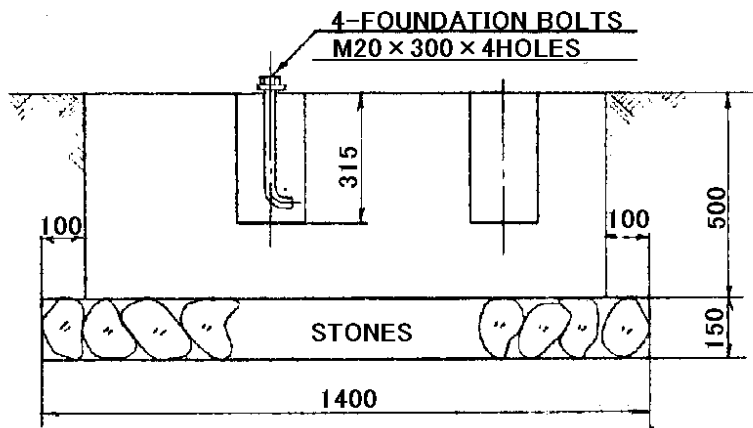
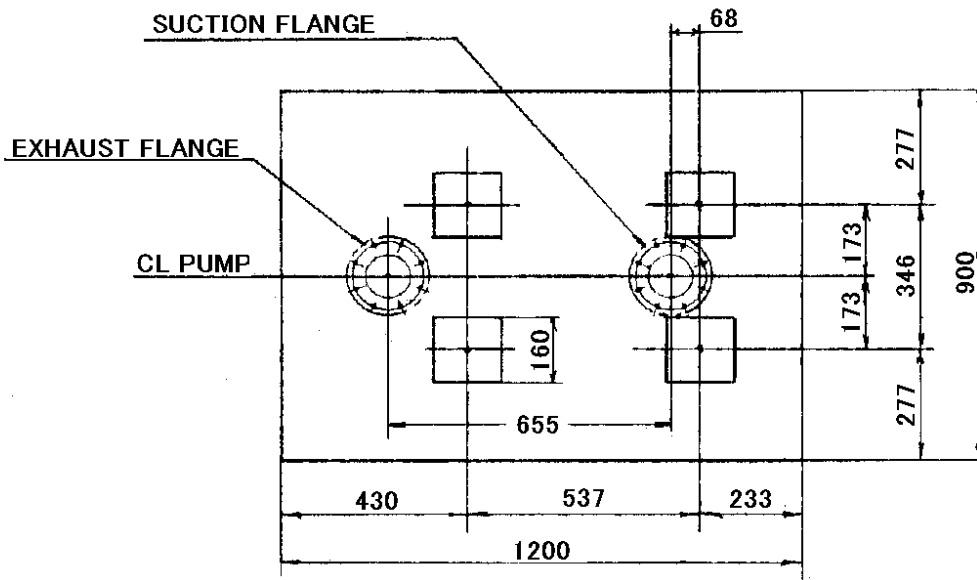
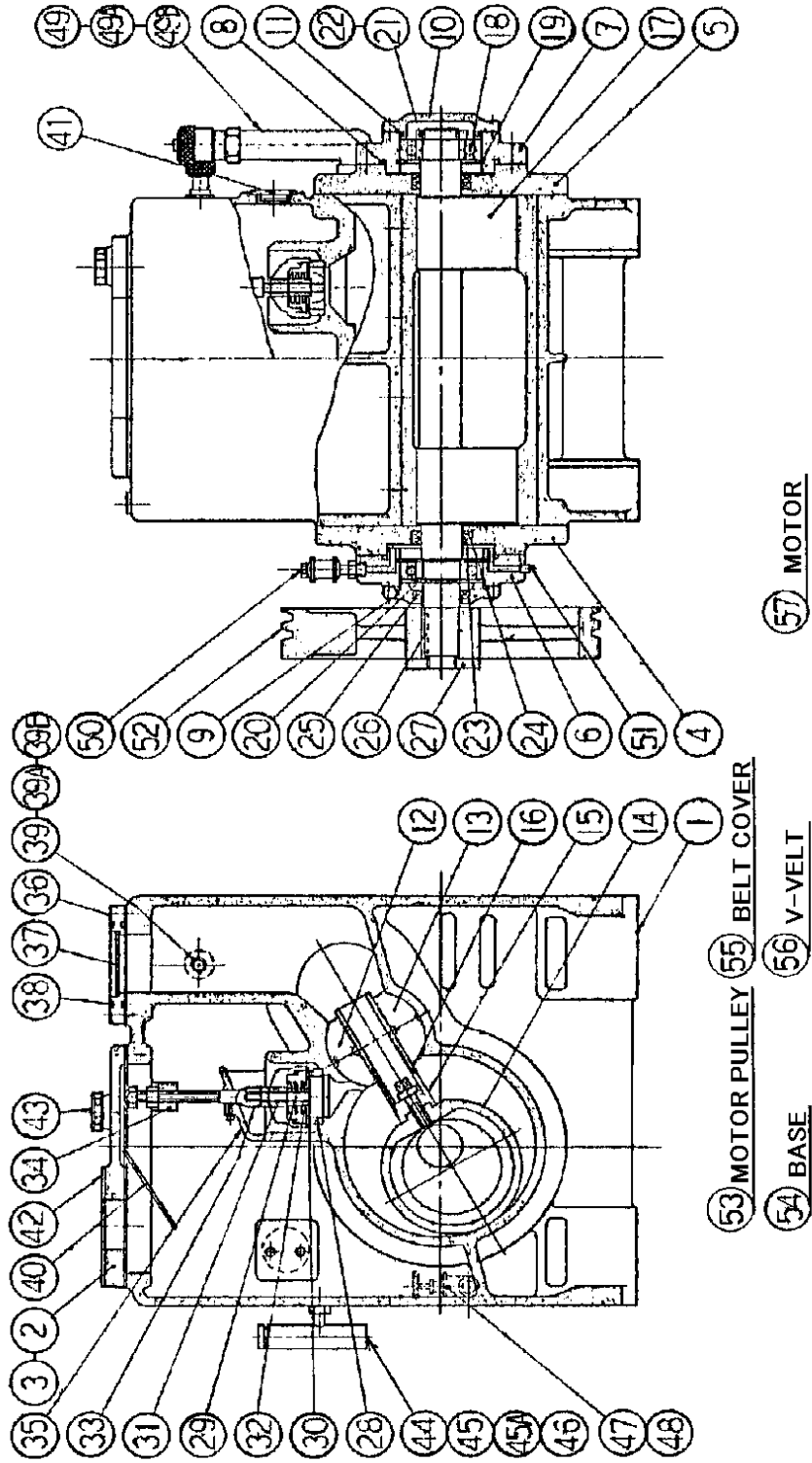

Fig. 9

PKS-0162 CONSTRUCTION PLAN

Fig. 10



ZZ-5192-1

PKS-0162 PARTS LIST

NO	NAME	MATL	QTY	NOTE	NO	NAME	MATL	QTY	NOTE
1	CYLINDER	FC250	1		33	VALVE FIXER	SS400	2	
2	UPPER COVER	FC200	1		34	VALVE FIXING SEAT	SS400	1	
3	COVER GASKET	VALQUA	1	#6500	35	OIL STOPPER	FC200	1	
4	FIRST COVER	FC250	1		36	SUCTION FLANGE	FC200	1	
5	SECOND COVER	FC250	1		37	FILTER	SS400	1	
6	BEARING CASE (A)	FC200	1		38	SUCTION GASKET $\phi 70 \times \phi 80 \times t5$	HYPAR	1	
7	BEARING CASE (B)	FC200	1		39	LEAK PORT		1SET	
8	O-RING G105	HYPAR	2	JISB2401	39A	SEAT GASKET (ULVAC No.2)	HYPAR	1	
9	BEARING FIXER (A)	FC200	1		39B	GASKET $\phi 17 \times \phi 22 \times t1$	FIBER	1	
10	BEARING FIXER (B)	FC200	1		40	BAFFLE	SPC	1	
11	O-RING G75	HYPAR	2	JISB2401	41	OIL GAUGE FIXER	AC3	1	
12	VANE GUIDE (A)	FC250	1		42	EXHAUST GASKET	VALQUA	1	#6500
13	VANE GUIDE (B)	FC250	1		43	CAP OF OIL FEEDING APERTURE	AC3	1	
14	ROTOR RING	FC250	1		44	ASSEMBLY OF OIL PIPINGS		1SET	
15	VANE	FC250	1		45	OIL FILTER		1SET	
16	FITTING BOLT	SCM435	1		45A	GASKET	VALQUA	1	#6500
17	ROTOR SHAFT	FCD450	1		46	MAGNETIC VALVE		1	
18	BEARING		2	#6307	47	DRAIN VALVE		1	PT3/8
19	SNAPRING	SUP2	2	$\phi 80$	48	NIPPLE	SGP	1	PT3/8
20	SNAPRING	SUP2	1	$\phi 35$	49	GAS BALLAST VALVE		1SET	
21	BEARING NUT	SS400	1		49A	SEAT GASKET (ULVAC No.1)	HYPAR	1	
22	BEARING WASHER	SPC	1		49B	O-RING P20	HYPAR	2	JISB2401
23	OIL SEAL SC406212	HYPAR	2		50	OILER		2	
24	OIL SEAL VC40625	HYPAR	2		51	PLUG	FCMB	1	
25	OIL SEAL TC355511	HYPAR	1		52	PUMP PULLEY	FC200	1	
26	PULLEY KEY	S45C	1		53	MOTOR PULLEY	FC200	1	
27	ROUND NUT	SS400	1		54	BASE	SS400	1	
28	VALVE SEAT	FC250	2		55	BELT COVER	SPC	1	
29	GUIDE PINI	SS400	2		56	V-BELT A-55"		3	
30	VALVE PLATE	SUS420	2		57	MOTOR 2.2kW 4P		1	
31	VALVE GUIDE	FC250	2		58	O-RING V70	HYPAR	1	JISB2401
32	VALVE SPRING	SUS304	2		59	OIL GAUGE GLASS $\phi 49 \times t5$		1	
					60	GASKET	VALQUA	2	#921
					61	RING GASKET $\phi 14 \times \phi 22 \times t1$	FIBER	2	
					62	SOLENOID VALVE BM-7M21		1	CKD

ZZ-5192-2C

PKS-0304 CONSTRUCTION

Fig. 11

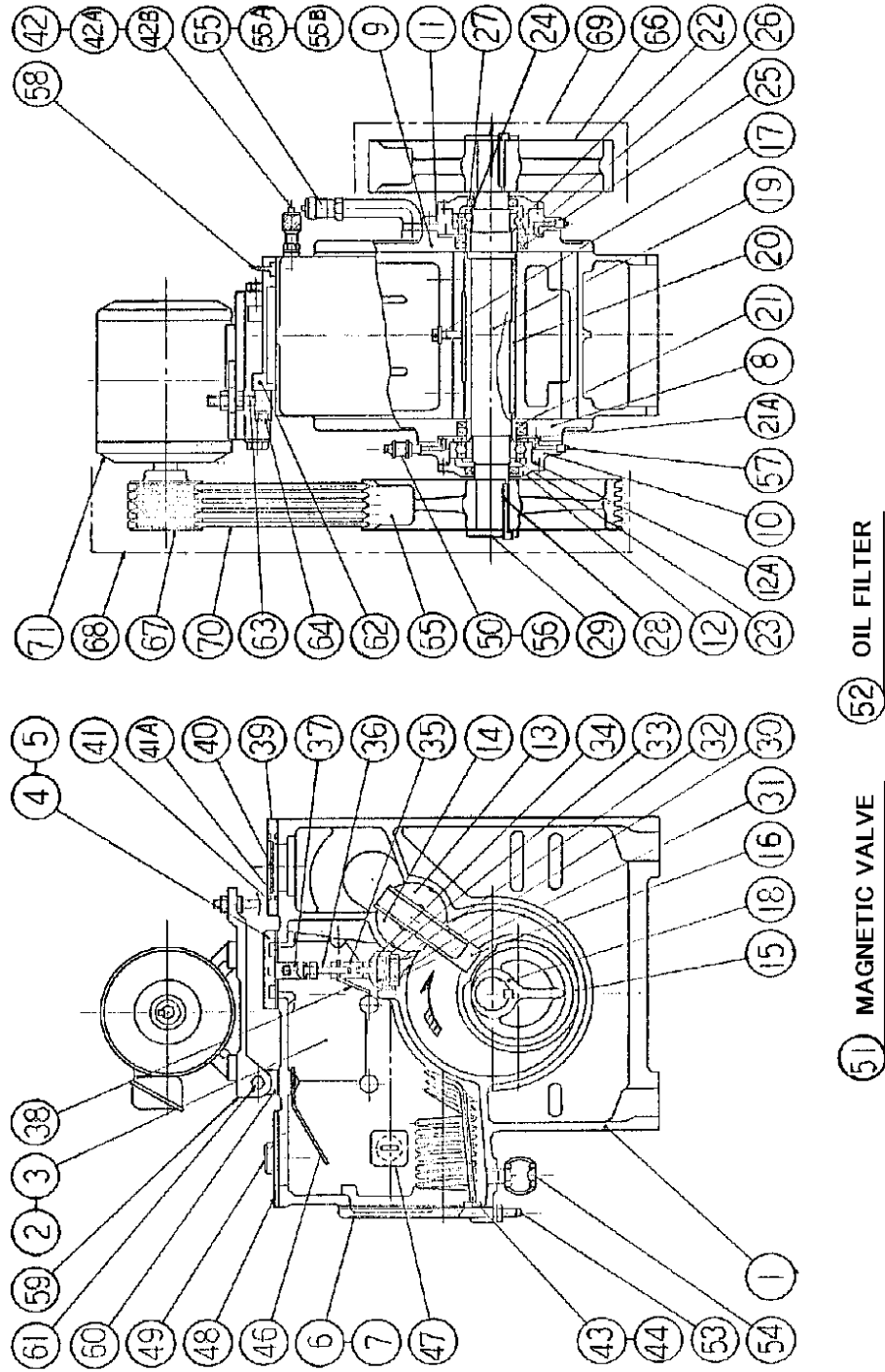

ZZ-5193-1

PKS-0304 PARTS LIST

NO	NAME	MATL	QTY	NOTE	NO	NAME	MATL	QTY	NOTE
1	CYLINDER	FC250	1		37	GUIDE SUPPORT	SS400	3	
2	REVERSE COVER	FC150	1		38	BAFFLE	SPC	1	
3	REVERSE COVER GASKET	VALQUA	1	#6500	39	SUCTION FLANGE	SS400	1	
4	UPPER COVER	FC150	1		40	FILTER	SS400	1	
5	UPPER COVER GASKET	VALQUA	1	#6500	41	SUCTION GASKET	HYPAR	2	
6	SIDE COVER	FC150	1		42	LEAK PORT		1 SET	
7	SIDE COVER GASKET	VALQUA	1	#6500	42A	SEAT GASKET	HYPAR	1	
8	1ST COVER	FC250	1		42B	GASKET	VALQUA	1	#6500
9	2ND COVER	FC250	1		43	COOLING PIPE	CUT	1 SET	
10	1ST BEARING CASE	FC200	1		44	GASKET	HYPAR	1	
11	2ND BEARING CASE	FC200	1		46	BAFFLE	SPC	1	
12	BEARING FIXER	FC200	2		47	OIL GAUGE		1	
12A	O-RING G130	HYPAR	1	JISB2401	48	EXHAUST GASKET	VALQUA	1	#6500
13	VANE GUIDE (A)	FC250	1		49	CAP OF OIL FEEDING APERTURE	AC3	1	
14	VANE GUIDE (B)	FC250	1		50	ASSEMBLY OF OIL PIPINGS		1 SET	
15	ROTOR RING	FC250	1		51	MAGNETIC VALVE		1	
16	VANE	FC250	1		52	OIL FILTER		1	
17	FITTING BOLT	SCM435	3		53	ASSEMBLY OF COOLING PIPINGS		1 SET	
18	ROTOR	FC250	1		54	DRAIN VALVE		1	
19	SHAFT	S45C	1		55	GAS BALLAST VALVE		1 SET	
20	ROTOR KEY	S45C	1		55A	SEAT GASKET	HYPAR	1	
21	COLLAR	FCD450	1		55B	GASKET	HYPAR	1	
21A	O-RING P50	HYPAR	2	JISB2401	56	OILER		2	
22	BEARING		2	#6410	57	DRAIN PLUG		2	
23	BEARING NUT (AN-10 LEFT)	SS400	1		58	EYE BOLT	S20C	1	
24	BEARING NUT (AN-10 RIGHT)	SS400	1		59	MOTOR BASE	FC150	1	
25	OIL SEAL VC65885		2		60	HINGE METAL FITTING	FC150	1	
26	OIL SEAL SC658812		2		61	HINGE PIN	SS400	2	
27	OIL SEAL TC478012		2		62	SLIDE METAL FITTING	FC150	1	
28	PULLEY KEY	S45C	2		63	SLIDE BOLT	FC150	1	
29	PULLEY FIXER PLATE	SS400	2		64	SLIDE PIN	SS400	1	
30	EXHAUST VALVE SEAT	FC250	3		65	PUMP PULLEY	FC200	1	
31	VALVE PLATE	SUS420	3		66	FLY WHEEL	FC200	1	
32	GUIDE PINI	SS400	3		67	MOTOR PULLEY	FC150	1	
33	VALVE SPRING	SUS304	3		68	BELT COVER	SS400	1	
34	VALVE GUIDE	FC250	3		69	WHEEL COVER	SS400	1	
35	VALVE FIXER	SS400	3		70	V-BELT 50Hz-A74 60Hz-A73		5	
36	VALVE FIXED BOLT	SS400	3		71	MOTOR 3.7kW 4P		1	

ZZ-5193-2A

PKS-0701 CONSTRUCTION PLAN

Fig. 12

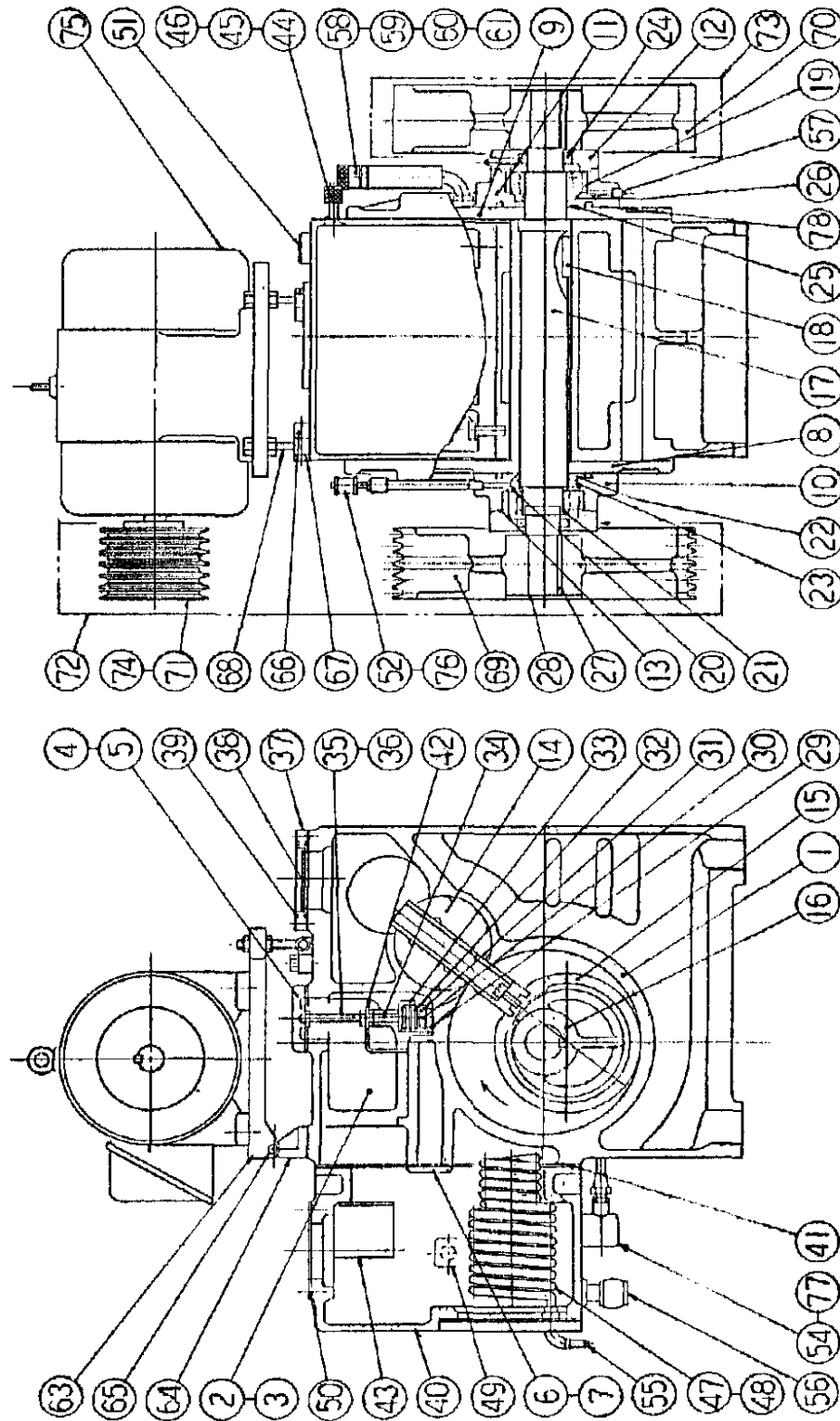

63 MAGNETIC VALVE 62 EYE BOLT

ZZ-1181-1A

PKS-0701 PARTS LIST

NO	NAME	MATL	QTY	NOTE	NO	NAME	MATL	QTY	NOTE
1	CYLINDER	FC250	1		41	SUCTION GASKET		1	
2	COVER	FC150	2		42	BAFFLE (A)	SPC	1	
3	COVER GASKET		2		43	BAFFLE (B)	SPC	1	
4	UPPER COVER	FC150	1		44	LEAK PORT		1	SET
5	UPPER COVER GASKET		1		45	SEAT GASKET	NBR	1	
6	JACKET BLIND COVER	FC150	2		46	GASKET	FIBER	1	
7	JACKET BLIND COVER GASKET		2		47	COOLING PIPE	CUT	1	
8	1ST COVER	FC250	1		48	GASKET	VALQUA	1	#6500
9	2ND COVER	FC250	1		49	OIL GAUGE		1	
10	1ST BEARING CASE	FC200	1		50	EXHAUST GASKET	VALQUA	1	#6500
11	2ND BEARING CASE	FC200	1		51	CAP OF OIL FEEDING APERTURE	AC3	1	
12	BEARING FIXER	FC200	2		52	ASSEMBLY OF OIL PIPINGS		1	SET
13	O-RING AN6230-31	HYPAR	1		53	MAGNETIC VALVE		1	
14	VANE GUIDE	FC250	1		54	OIL FILTER		1	
15	SLIDE VANE	FC250	1		55	ASSEMBLY OF COOLING PIPINGS		1	SET
16	ROTOR	S55C	1		56	DRAIN VALVE		1	
17	SHAFT	S45C	1		57	DRAIN PLUG		2	
18	ROTOR KEY	S45C	2		58	GAS BALLAST VALVE		1	SET
19	BEARING		2	#21313	59	SEAT GASKET #4	NBR	1	
20	BEARING LOCK WASHER	SS400	1		60	O-RING P28	NBR	1	
21	BEARING NUT	SS400	1		61	O-RING P25	NBR	4	
22	OIL SEAL VC70955	NBR	1		62	EYE BOLT	S20C	1	M16
23	OIL SEAL <small>SC709513 (VACUUM TIGHT TYPE)</small>	NBR	1		63	MOTOR BASE	FC150	1	
24	OIL SEAL TC628512	NBR	2		64	HINGE METAL FITTING	FC150	2	
25	OIL SEAL VC65885	NBR	1		65	HINGE PIN	SS400	2	
26	OIL SEAL <small>SC658812 (VACUUM TIGHT TYPE)</small>	NBR	1		66	SLIDE METAL FITTING	FC150	2	
27	PULLEY KEY	S45C	2		67	SLIDE PIN	SS400	2	
28	PULLEY FIXER PLATE	SS400	2		68	SLIDE BOLT	SS400	2	
29	VALVE SEAT	SUS420J2	6		69	PUMP PULLEY	FC200	1	
30	VALVE PLATE	SUS304	6		70	FLY WHEEL	FC200	1	
31	VALVE SUPPRESSOR	SUS420J2	6		71	MOTOR PULLEY	FC150	1	
32	VALVE SPRING	SWP-B	6		72	BELT COVER	SS400	1	
33	VALVE HOLDER	FC200	6		73	WHEEL COVER	SS400	1	
34	VALVE SUSTAINING NUT	SS400	6		74	V-BELT <small>50Hz-B96 60Hz-B94</small>		6	
35	VALVE SUSTAINING BOLT	SS400	6		75	MOTOR 11kW 6P		1	
36	HEXAGON NUT	SS400	8		76	OILER		2	
37	SUCTION FLANGE	SS400	1		77	OIL FILTER GASKET	NBR	1	
38	FILTER	BSW	1		78	LIQUID GASKET (THREE BOND No.2)			
39	SUCTION GASKET	NBR	1						
40	OIL TANK	FC200	1						

ZZ-1181-2B