



OPERATING INSTRUCTIONS

EN

Translation of the original instructions

DUO 20 M, DUO 20 MC

Rotary Vane Pump

PFEIFFER  **VACUUM**

Table of contents

1	About this manual	3
1.1	Validity	3
1.2	Conventions	3
2	Safety	5
2.1	Safety precautions	5
2.2	Protective equipment	5
2.3	Proper use	6
2.4	Improper use	6
3	Transport and storage	7
3.1	Transport	7
3.2	Storage	7
4	Product description	8
4.1	Product identification	8
4.2	Function	9
5	Installation	10
5.1	Setting up the pump	10
5.2	Connecting the vacuum side	10
5.3	Connecting the exhaust side	11
5.4	Connecting to the mains power supply	11
5.5	Filling up the operating fluid	16
5.6	Operations monitoring (Option)	17
6	Operation	18
6.1	Before switching on the pump	18
6.2	Switching on the pump	18
6.3	Pumping condensable vapours	19
6.4	Topping up the operating fluid	20
6.5	Switching off the pump	21
7	Maintenance	22
7.1	Precautions	22
7.2	Changing the operating fluid	24
7.3	Changing the kind of operating fluid	26
7.4	Cleaning the gas ballast valve	27
8	Decommissioning	29
8.1	Shutting down for longer periods	29
8.2	Re-starting	29
8.3	Disposal	29
9	Malfunctions	30
9.1	Rectifying malfunctions	31
10	Service	32
11	Spare parts	33
11.1	Spare parts packages	33
12	Accessories	35
13	Technical data and dimensions	36
13.1	General	36
13.2	Technical data	37
13.3	Dimensions	38
	Declaration of conformity	39

1 About this manual

1.1 Validity

This operating manual is for customers of Pfeiffer Vacuum. It describes the functioning of the designated product and provides the most important information for safe use of the unit. The description follows applicable EU guidelines. All information provided in this operating manual refers to the current state of the product's development. The documentation remains valid as long as the customer does not make any changes to the product.

Up-to-date operating instructions can also be downloaded from www.pfeiffer-vacuum.com.

Applicable documents

DUO 20 M/MC	Operating instructions
Declaration of Conformity	Part of this document
Operating instructions for accessories (order-specifically)	see section "accessories"

*also available via www.pfeiffer-vacuum.com

For information about other certifications, if applicable, please see the signet on the product or:

→ www.tuvdotcom.com

→ TUVdotCOM-ID 0000021320

1.2 Conventions

Safety instructions

The safety instructions in Pfeiffer Vacuum operating instructions are the result of risk evaluations and hazard analyses and are oriented on international certification standards as specified by UL, CSA, ANSI Z-535, SEMI S1, ISO 3864 and DIN 4844. In this document, the following hazard levels and information are considered:

DANGER
<p>Imminent danger Indicates an imminent hazardous situation that will result in death or serious injury.</p>
WARNING
<p>Possibly imminent danger Indicates an imminent hazardous situation that can result in death or serious injury.</p>
CAUTION
<p>Possibly imminent danger Indicates an imminent hazardous situation that can result in minor or moderate injury.</p>
NOTICE
<p>Command or note Command to perform an action or information about properties, the disregarding of which may result in damage to the product.</p>

Pictographs



Prohibition of an action to avoid any risk of accidents, the disregarding of which may result in serious accidents



Warning of a displayed source of danger in connection with operation of the unit or equipment



Command to perform an action or task associated with a source of danger, the disregarding of which may result in serious accidents



Important information about the product or this document

Instructions in the text

→ Work instruction: here you have to do something.

Abbreviations

C version: Corrosive gas version

OME: Oil mist eliminator

ODK: Oil drain kit with return unit

Symbols used

The following symbols are used consistently throughout in all illustrations:

- ⓪ Vacuum flange
- Ⓛ Exhaust flange
- Ⓜ Gas ballast valve
- Ⓝ Power connection

2 Safety

2.1 Safety precautions



Duty to inform

Each person involved in the installation, operation or maintenance of the vacuum pump must read and observe the safety-related parts of these operating instructions.

→ The operator is obligated to make operating personnel aware of dangers originating from the vacuum pump, the pumped medium and the entire system.



Installation and operation of accessories

Pfeiffer Vacuum pumps can be equipped with a series of adapted accessories. The installation, operation and maintenance of connected devices are described in detail in the operating instructions of the individual components.

→ For information on order numbers of components, see "Accessories".

→ Use original accessory parts only.

- Do not expose any body parts to the vacuum.
- Observe the safety and accident prevention regulations.
- Check regularly that all safety precautions are being complied with.
- Do not carry out any unauthorised modifications or conversions to the pumps.
- Depending on the operating and ambient conditions, the surface temperature of the pumps may rise above 70 °C. Use suitable finger guards if necessary.
- When returning the pumps to us please note the instructions in the Service section.

The following safety instructions are only valid for the disassembly of the drive system for a vacuum pump with a magnetic coupling:

- When disassembling the drive system from the pump housing, the strong magnetic field may influence the function and operational reliability of electrical and electronic devices.
- Persons with cardiac pacemakers must keep away from the magnetic coupling.

Danger to life!

– **Minimum distance: 2 m!**

- Disassembled magnetic couplings must be kept away from computers, data storage media and other electronic components.
- Keep the disassembled components of the magnetic coupling separate at all times. Danger of crushing!
- Do not allow any magnetised parts into the vicinity of the magnetic coupling. Danger of injury!

2.2 Protective equipment

Determined situations concerning the handling of vacuum pumps require wearing of personal protective equipment. The owner, respectively the employer are obligated to provide an adequate equipment to any operating persons.



DANGER

Danger to health by hazardous substances during maintenance or installation

Depending on the process vacuum pumps, components or operating fluids can be contaminated by toxic, reactive or radioactive substances.

→ Wear adequate protective equipment during maintenance and repairs or in case of reinstallation.



CAUTION

Risk of injury through hot surfaces

Vacuum pumps can become hot during operation.

- Allow the pump to cool before maintenance and repairs.
- If necessary wear protective gloves according to EN 420.

CAUTION

Increased noise emission!

Increased noise emission can occur within a limited area surrounding the vacuum pump.

- Provide noise protection or
- wear hearing protection.

2.3 Proper use



NOTICE

EC conformity

The manufacturer's declaration of conformity becomes invalid if the operator modifies the original product or installs additional components.

- Following installation into a plant and before commissioning, the operator must check the entire system for compliance with the valid EU directives and reassess it accordingly.

- The vacuum pump may only be used to generate a vacuum.
- Only use the vacuum pump for applications with oxygen concentration $\leq 21\%$.
- Installation, operating and maintenance regulations must be complied with.
- Other accessories, than those described in this manual, must not be used without the agreement of Pfeiffer Vacuum.

2.4 Improper use

Improper use will cause all claims for liability and warranties to be forfeited. Improper use is defined as usage for purposes deviating from those mentioned above, especially:

- pumping of corrosive gases (exception: pumps in C version)
- pumping of explosive media
- operation in potentially explosive areas
- pumping of gases containing impurities such as particles, dusts and condensate; note the vapour compatibility levels of the pump
- pumping of substances that tend to sublime
- use of the vacuum pump to generate pressure
- pumping of liquids
- the use of operating fluids not specified by Pfeiffer Vacuum
- connection to pumps or units which are not suitable for this purpose according to their operating instructions
- connection to units which have exposed voltage-carrying parts

3 Transport and storage

3.1 Transport

Transport instructions

- Remove the locking cap from the vacuum and exhaust flange immediately before connecting!
 - Check the protective strainer, paying attention to the O-ring.
- Use only the handle or the crane eye on the top side of the pump to lift the pump.
 - Is the pumps weight > 25 kg lift the pump by a crane.

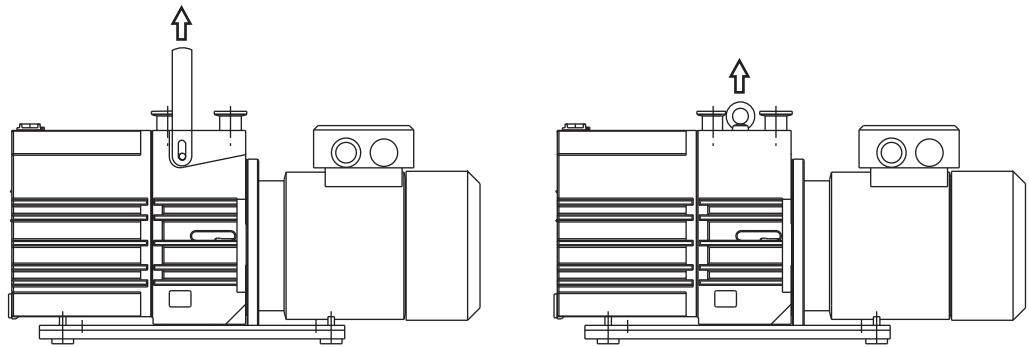

Fig. 1: Transporting the pump

3.2 Storage

- Check that all the openings on the pump are securely closed.
- Fill up the pump with new operating fluid to the top edge of the sight glass.
- Store the pump only dry and dust-free indoors within the specified environmental conditions.
 - In rooms with moist or aggressive atmospheres, the pump must be airproof shrink-wrapped in a plastic bag together with a bag of desiccant.
 - After storage periods longer than two years, it is recommended to carry out maintenance and change the operating fluid before using the pump.

4 Product description

4.1 Product identification

To correctly identify the product when communicating with Pfeiffer Vacuum, always have the information from the rating plate available and use it:

- Pump model and model number
- Serial number
- Type and amount of operating fluid
- Date of manufacture

Please find the voltage range and motor-related data on the separately attached motor rating plate.

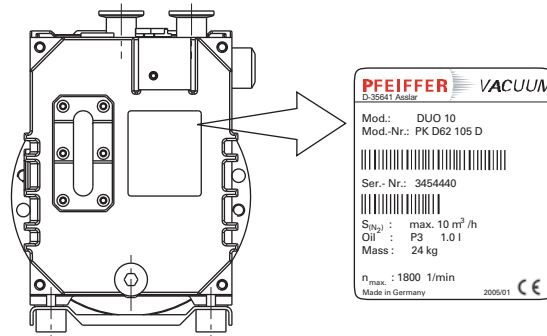

Fig. 2: Product identification on the rating plate

Scope of delivery

- Pump with motor (mains cable/power switch --> dependent on the motor type)
- Operating fluid (except F4 and F5)
- Cone strainer and centering ring with O-ring
- Locking cap for vacuum and exhaust flange
- Operating instructions

Variants

Pump type	Pump versions
DUO 20 M	Standard version of pump
DUO 20 MC	C version of pump; differences from the standard version: <ul style="list-style-type: none"> • Operating fluid F4 • Encapsulated can of the magnetic coupling at the pump system • Vane material changed • Gas ballast valve with dosable flushing gas connection • Leak rate $\leq 1 \cdot 10^{-6}$ Pa m³/s

4.2 Function

The vacuum pumps of the DuoLine™ are dual stage rotary vane pumps and are used primarily for rough and medium vacuum applications. The pumps are fitted with a hydraulically controlled vacuum safety valve which, when the pump is at a stillstand, closes the vacuum chamber vacuum tight and at the same time vents the pump. The integrated magnetic coupling functions free of contact and friction. Therefore it is not subjected to any mechanical wear and is completely maintenance free compared to a conventional shaft feedthrough.

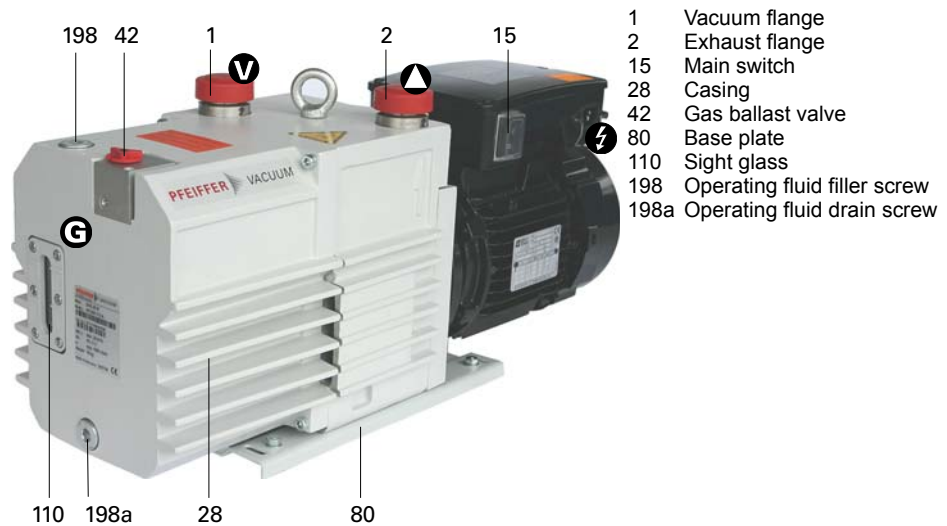

Fig. 3: Rotary Vane Pump DUO 20 M

5 Installation

5.1 Setting up the pump

Installation location

Observe the following requirements when setting up the pump:

- Consider the load-bearing capacity of the installation site.
- Maximum installation altitude 2000 m (above mean sea level)
- Permissible ambient temperature: +12 ... 40 °C
- Maximum relative humidity 85%

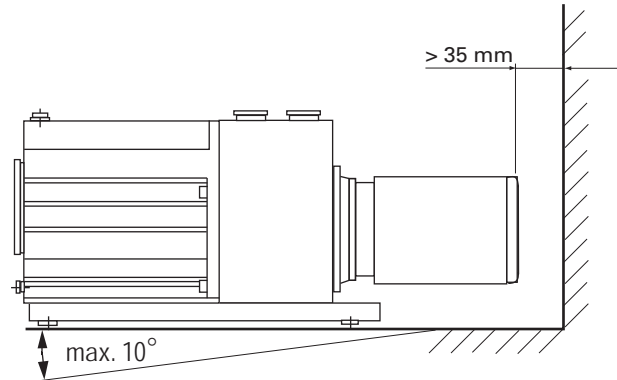

Fig. 4: Setting up the pump

- Fill up with operating fluid before operating the first time (see p. 16, chap. 5.5).
 - Amount and type according to rating plate
- Always place the pump on a firm, even surface.
 - The base frame has four holes for anchoring onto the base.
- When installing the pump in a closed housing, ensure there is sufficient air circulation.
 - Sight glass and gas ballast valve must be visible and readily accessible.
 - Voltage and frequency information given on the motor rating plate must be visible.

5.2 Connecting the vacuum side

- Remove locking cap from the vacuum flange;
 - pay attention to the cone strainer and the respective O-ring in the intake port.
- The connection between the pump and the vacuum chamber should be kept as short as possible.
 - Depending on the pump type, use metallic hoses or PVC hoses with flange connections.
 - Separators, filters etc. may be installed upstream to protect the pump (see accessories). However, please observe the loss of pumping capacity due to the conductivity of the accessories.

5.3 Connecting the exhaust side



CAUTION

High pressure in the exhaust line!

Danger of damage to the seals and danger of the pump bursting.

- Observe the maximum permissible pressure of 1500 hPa (absolute), activate shut-off valves in such a way that they open before or at the same time as the pump is started.



NOTICE

Reduced pressure in the exhaust line!

Reduced pressure in the exhaust line can cause malfunctions and damage the pump.

It is only allowed in pumps with magnetic coupling.

- Ensure that when discharging gases the exhaust pressure is at least 250 hPa higher than the suction pressure.



WARNING

Emission of toxic substances from the exhaust!

Danger of poisoning from emitted gases or vapours, which can be detrimental to health and/or can pollute the environment, depending on the particular application.

- Comply with the applicable regulations when working with toxic substances.
 - Only officially approved filter systems may be used to separate and remove these substances.
- Choose the cross-section of the exhaust line to be at least the size of the nominal connection diameter of the vacuum pump's exhaust connection.
 - Piping to the pump must be suspended or supported.
 - Physical forces from the piping system must not be allowed to act on vacuum pumps.
 - Lay piping from the pump sloping downward so that no condensate can flow back into the pump; otherwise fit a condensate separator.
 - If an air trap is created in the system, then a device for draining condensation water must be provided at the lowest point.

5.4 Connecting to the mains power supply

Depending on the pump type, different motor versions or mains voltages are possible:

- Single phase motor for fixed voltage with a built-in thermal protection switch, mains switch and connecting cable.
- Single phase motor with switchable voltage range,
 - thermal protection switch,
 - mains switch and
 - mains connection socket (C14)
- Three phase motor (without switch and mains cable).



DANGER

Voltage-bearing elements

Danger to life from electric shock.

- The electrical connection can be carried out only by trained and authorised electricians.
- Disconnect the power supply and secure it against being switched back on.
- Ensure the system is adequately earthed.

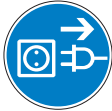

NOTICE

Excess voltage!
 Danger of destroying the motor.
 → Power connections must comply with local regulations. Voltage and frequency information given on the motor rating plate must correspond to the mains voltage and frequency values.
 → To protect the motor and supply cable in case of malfunction, mains fuse protection must be implemented. Recommended: Type K slow blow circuit breaker.



WARNING

Danger of injury from moving parts!
 After power failure or motor shutdown due to overheating, the motor may restart automatically.
 → Secure the motor so that it cannot be switched on while any work is being performed on the pump.
 → If necessary, dismantle the pump from the installation for inspection.

Single phase motors

→ The mains voltage must be determined on-site each time before the pump is installed or moved to a different location.



NOTICE

Overvoltage!
 An incorrect voltage range setting can damage the motor.
 → Always check the set voltage range before switching on the pump.
 → Only change the voltage range when the pump is disconnected from the power mains.

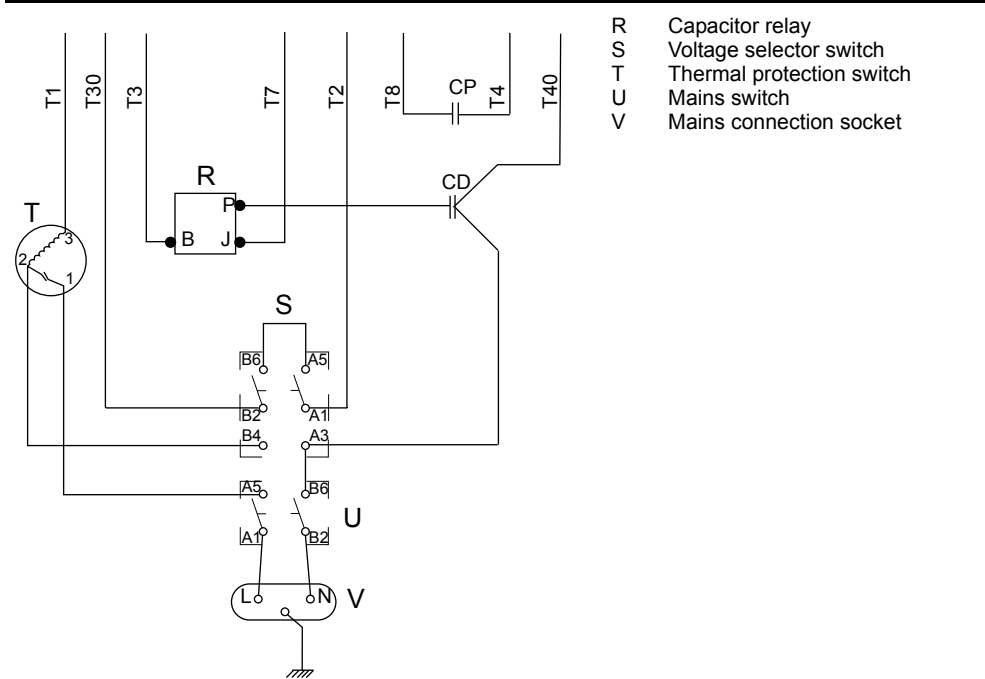
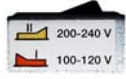
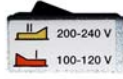

Fig. 5: Connection diagram (terminal box)

Changing the voltage range

- Disconnect the pump from the power supply.
- Set the rocker switch "S" in the motor terminal box to the desired voltage range.

Rocker switch in the terminal box for changing the voltage range

Switch position:		
Voltage range:	200 ... 230 V/50 Hz 200 ... 240 V/60 Hz	100 ... 110 V/50 Hz 100 ... 120 V/60 Hz

Fuse protection



The transmission power of the pump's magnetic coupling is so great that the coupling is no overload protection for the motor.

- ➔ To protect the motor in case of malfunction, additionally provide a fuse protection in accordance with the regional regulations.
 - Select a fuse with slow characteristics according to the table below.

Voltage [V]	Frequency [Hz]	Motor rating [kW]	I_N [A]	I_{max} [A]
100 - 110	50	0.75	12.0	86.1
200 - 230	50	0.75	6.5	48.6
100 - 120	60	0.90	13.0	88.3
200 - 240	60	0.90	6.5	46.4

Three-phase motor

The three-phase current motor circuit

The connections U1 - L2, V1 - L1 and W1 - L3 result in a clockwise rotation of the motor shaft as seen looking towards the motor fan.

Delta Connection

The three coils are connected in series with the connection point connected to the mains. The voltage of each coil is the same as the mains voltage whereas the mains current is the cube root of the coil current. Delta connections are denoted by the symbol Δ . The voltage between the mains supply lines is called mains voltage. The mains current is the current which flows in the supply lines.

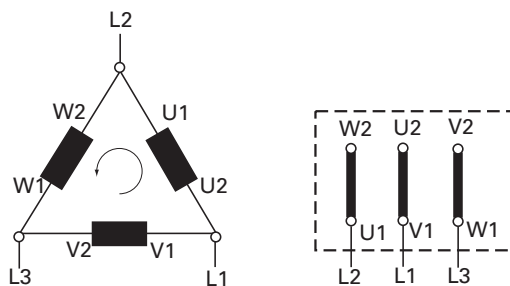

Fig. 6: Motor coil and connecting plate of Delta Connection (for low voltage)

Star Connection

The ends of the three coils are connected at the star center. The terminal voltage is the cube root of the coil voltage; the mains and the coil current are the same. Star connections are denoted by the symbol Y .

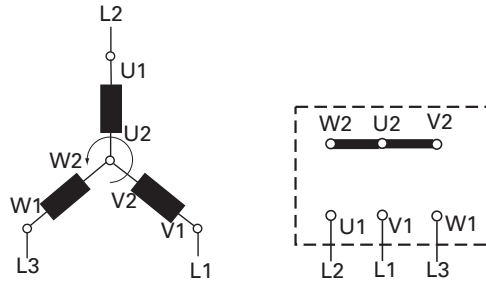

Fig. 7: Motor coil and connecting plate of Star Connection (for high voltage)



NOTICE

Do not start with star/delta connection.

→ Always start motor directly.

Inspection of the direction of rotation

For pumps with three-phase motors, it is necessary to check the direction of rotation!



CAUTION

Operating fluids may leak out!

If the direction of rotation is incorrect, there is a danger that operating fluids may leak at the vacuum flange.

→ Always check the direction of rotation before filling in operating fluid.

→ Remove the locking cap from the exhaust flange (if existing).

→ Switch the pump on briefly (from 2 to 3 sec.).

– The motor and motor fan must turn in a clockwise direction (see the arrow on the support stand).

→ If the direction of rotation is incorrect: Swap two phase contacts at the connecting cable.

→ Fill up the operating fluid.

Motor protection



The transmission power of the pump's magnetic coupling is so great that the coupling is no overload protection for the motor.

With PTC temperature sensors (3PTC)

Pump motors equipped with PTC temperature sensors (3PTC) in the stator windings can be connected to a PTC resistor tripping device for protection against overload. Other approved motor temperature monitoring can be used also by the operator.

Tripping devices store the shutdown event and need to be manually switched back on again via the integrated RESET button or via the external RESET S3. Mains-ON is detected as an automatic RESET.

→ Set up the connections so that the directional rotation indicated on the pump is maintained, regardless of the representations in the current flow diagram.

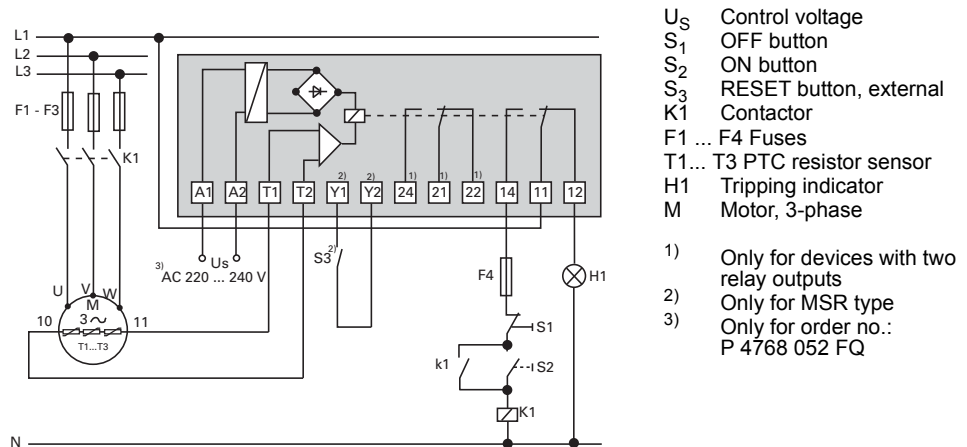

Fig. 8: Connection example for a three-phase AC motor with PTC resistor tripping device

With motor protection switch

Suitable are protection switches with slow triggering characteristics. The drive motor can have a power consumption that is higher than the rated current I_N . According to DIN EN 60034-1 it is permissible to exceed the rated current I_N 1.5 times for a period of 2 minutes. The setting must permit the overload ability of the motor and can be found in the following table.

DUO 20 M/MC

Voltage [V]	Frequency [Hz]	Motor rating [kW]	I_N [A]	I_{max} [A]
230	50	0,55	2,8	12
400	50	0,55	1,6	7
275	60	0,65	2,91	13
480	60	0,65	1,67	7,5
200	50	0,55	2,95	12,5
346	50	0,55	1,7	7
220	60	0,55	2,5	13
380	60	0,55	1,45	7,5
200	50	0,55	2,95	12,5
	60	0,55	2,7	11

Motor control system

Frequency converter (valid for three phase motors)

Operation of rotary vane pumps with variable rotation speeds is possible in the mains frequency range between 35 and 60 Hz. The start-up can use a ramp (run-up time: max. 30 s); the shutdown can occur directly.

5.5 Filling up the operating fluid

The type and amount of operating fluid should be visible on the pump's rating plate for every rotary vane pump.

Permissible operating fluids

- P3 (Standard operating fluid)
- F4 (Operating fluid for corrosive gas versions)
- D1 (for special applications e. g. higher operating temperature)
 - Ultimate pressure of measurement, depending on the type of gas: $< 5 \cdot 10^{-2}$ hPa



NOTICE

Use approved operating fluids only!

The use of operating fluids that have not been approved by Pfeiffer Vacuum shall result in a limited warranty. In such cases, it is not possible to guarantee that product-specific performance data will be achieved.

→ Prior consultation is required before using other application-specific operating fluids.

Filling up the operating fluid

- Unscrew operating fluid filler screw 198.
- Fill up the operating fluid.
 - First fill when the pump is cold: Maximum 3/4 of the min./max. range.
- Screw in operating fluid filler screw 198.

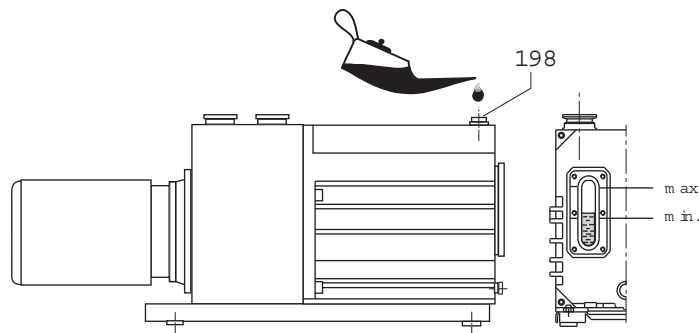

Fig. 9: Filling up the operating fluid



WARNING

Toxic vapours!

Danger of poisoning when igniting and heating synthetic operating fluids (e.g. F4/F5) above 300 °C.

- Observe the application instructions.
- Do not allow operating fluid to make contact with tobacco products; observe safety precautions when handling chemicals.

5.6 Operations monitoring (Option)

For operations monitoring a pressure switch can be installed on the side of the support. In case of a malfunction, e. g. pressure drop or when the pump is at rest, the contact of the pressure switch opens. The signal can be used to control external valves.

Switching voltage:	5 ... 250 Volt (potential-free)
Current, max.	2 Amp.
Protection class	IP 55

1 + 2 closers = pressureless open

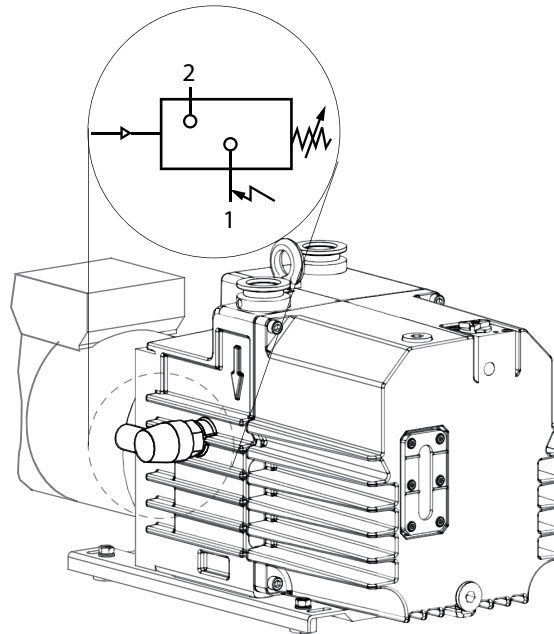

Fig. 10: Installation location and circuit diagram of pressure switch

- Switch off the pump.
- Unscrew and remove locking screw 142 on the support.
- Screw in pressure switch with O-ring.
- Remove protective cover and make electrical connections at the pressure switch.
- Reassemble the protective cover.

6 Operation

6.1 Before switching on the pump

- Check the operating fluid level in the sight glass.
- Compare the voltage and frequency information on the rating plate with the mains voltage and frequency values.
- Check that the exhaust connection allows free flow (max. permissible pressure 1500 hPa absolute).
 - Activate the shut-off valves in such a way that they open before or at the same time as the pump is started.
- Protect the pump sufficiently from taking in contaminants by means of suitable precautions (e.g. dust filters); if necessary, check operating fluid regularly or replace at shorter intervals.

6.2 Switching on the pump

The pump can be switched on in any pressure range between atmospheric and ultimate pressure.

The ideal operating condition of the pump is achieved during continuous operation. Cyclic operation is possible, but 10 cycles per hour should not be exceeded and the operating phase should always be longer than the downtime (non-operation time).

No special precautions are necessary when pumping dry gases. In order to attain the lowest possible ultimate pressures, the gas ballast valve should be closed.



NOTICE

Increased motor current draw (> rated current) !

With an intake pressure of about 300 hPa, the pump has the highest power requirement, which can increase even further under unfavorable operating conditions (e.g. counter-pressure on exhaust side).

- Limit the max. power consumption for 1.5 times the rated current for 2 minutes max. (according to DIN EN 60034-1).



CAUTION

Hot surface!

Danger of burns if hot parts are touched. Depending on the operating and ambient conditions, the surface temperature of the pump may rise above 70 °C.

- In this case, use suitable finger guards.
- Switch on pump at main switch 15.
- Switch on the pump with the vacuum flange closed and allow to warm up for 30 minutes.
- Check operating fluid level only when the pump is warm and running; therefore
 - close vacuum flange and gas ballast valve,
 - correct filling level during operations: within the markings at the sight glass frame,
 - check operating fluid daily in non-stop operation, otherwise whenever the pump is switched on. Refilling is possible when the pump is in final vacuum operation.

6.3 Pumping condensable vapours

Should the process gases contain condensable gases, the rotary vane pump must be operated with gas ballast (i.e. with an open gas ballast valve).



NOTICE

Bad final vacuum and damage to the pump!

Danger of condensation and corrosion due to exceeding the water vapour compatibility during operation without gas ballast or in case of insufficient supply of flushing gas.

- Only pump vapours when the pump is warm and the gas ballast valve is open.
- When the process has been completed, allow the pump to continue running for about 30 minutes with the vacuum flange closed and the gas ballast open for operating fluid regeneration purposes.

Gas ballast valve, standard version

To avoid condensation in the pump when pumping condensable vapours, air is periodically fed into the working chamber at the beginning of the compression phase via the gas ballast valve 42.

The gas ballast valve is closed when turning to the right to position 0 and open when turning to the left to position 1. Intermediate settings are not possible.

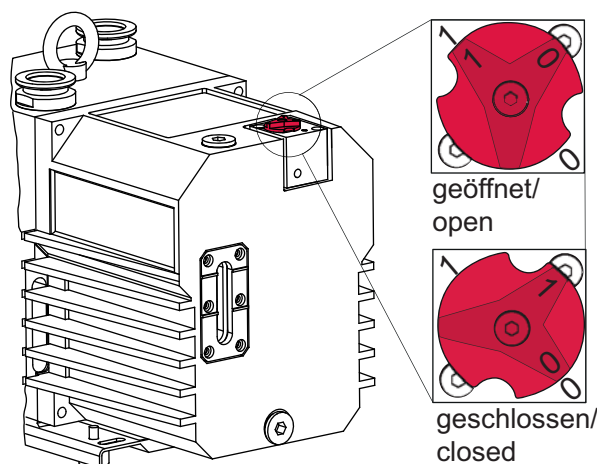

Fig. 11: Standard version 42 of gas ballast valve

Gas ballast valve with flushing gas connection (option)

If the pumping process requires the use of flushing gas, a supply hose can be connected at the gas ballast valve.

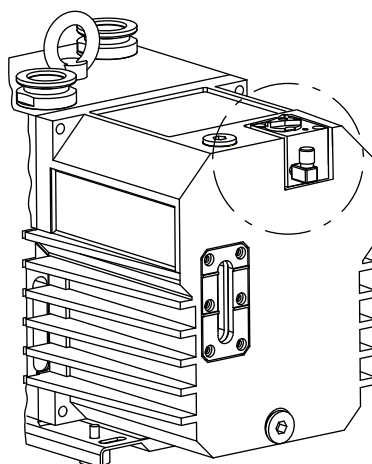

Fig. 12: Gas ballast valve with flushing gas connection



NOTICE

Flushing gas pressure higher than allowed endangers the operational reliability of the pump.

The power input of the pump, the temperature and the ejection of operating fluid will increase.

- Observe the maximum permissible flushing gas pressure.
- Set the amount of flushing gas on site.
- Connect flushing gas at the flushing gas connection.
- Set flushing gas pressure; maximum pressure 1500 hPa (absolute).
 - Select the type and amount of flushing gas depending on the process; consult Pfeiffer Vacuum if necessary.
 - Amount of flushing gas max. 1260 l/h.

6.4 Topping up the operating fluid

If the operating fluid has reached its minimum filling level, the operating fluid must be topped up. The fluid can be topped up during operation in the final vacuum.

Filling up the operating fluid

- Unscrew operating fluid filler screw 198.
- When the pump is at operation temperature, top up the operating fluid up to the "max." marking.
- Screw in operating fluid filler screw 198.

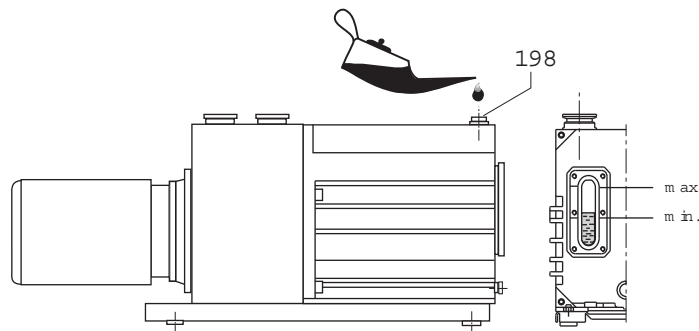

Fig. 13: Filling up the operating fluid

6.5 Switching off the pump

The pump can be switched off in any pressure range.

Rotary vane pumps have an integrated safety valve on the intake side. If the differential pressure between the exhaust side and the intake side is ≥ 250 hPa, then the valve closes automatically and vents the pump when the pump is switched off.

→ Switch the pump off at the mains switch or disconnect from the mains in a secure manner.

Venting the vacuum chamber



NOTICE

Danger of backflow of operating fluid into the intake line!

Contamination of the connected vacuum system!

- Vent the vacuum chamber within 30 s, regardless of the chamber size.
- For a longer venting process, use an additional shut-off valve and shut off the intake line after switching off the pump.

Maintaining the vacuum in the chamber



NOTICE

Danger of backflow of operating fluid into the intake line!

Contamination of the connected vacuum system!

- Because the safety valve of the pump is not suitable for longer-term sealing, install an additional shut-off valve in the intake line.
- Shut off the intake line immediately after switching off the pump.

7 Maintenance

7.1 Precautions



DANGER

Strong magnetic field in the vicinity of the drive system!

Danger to life for persons with cardiac pacemakers when the drive system is disassembled.

- Persons with cardiac pacemakers must not enter the area ($\leq 2\text{m}$) of the magnetic field.
- Rooms in which open couplings are accessible must be identified: "No trespassing for persons with heart pacemaker"!
- Disassembled magnetic couplings must be kept away from computers, data storage media and other electronic components.

WARNING

Danger of injury from moving parts!

After power failure or motor shutdown due to overheating, the motor may restart automatically.

- Secure the motor so that it cannot be switched on while any work is being performed on the pump.
- If necessary, dismantle the pump from the installation for inspection.

WARNING

Pump parts may be contaminated from pumped media!

Danger of poisoning due to contact with harmful substances.

- Decontaminate the pump before carrying out any maintenance work.
- In the event of contamination, take suitable safety precautions to prevent your health from being harmed by any dangerous substances.
- Turn off the vacuum pump, vent to atmospheric pressure and allow to cool.
- Disconnect the drive motor from the mains and secure it so that it cannot be switched on.
- Only dismantle the pump as far as necessary to carry out maintenance.
- Dispose of used operating fluid in compliance with local regulations.
- When using synthetic operating fluids or working with toxic substances or substances contaminated with corrosive gases, the relevant instructions governing their use must be observed.
- Use only alcohol or similar agents for cleaning pump parts.

Checklist for inspection, maintenance and overhaul

Certain maintenance and overhaul work should only be performed by Pfeiffer Vacuum Service (PV). Pfeiffer Vacuum will be released from all warranty and liability claims if the required, below listed, intervals are exceeded or maintenance or overhaul procedures are not performed properly. This also applies if replacement parts other than Pfeiffer Vacuum OEM replacement parts are used.

Activity	daily	as required; at least annually	as required; at least every 2 years	as required; at least every 4 years
Check operating fluid level	X			
Visual inspection (leak-tightness/oil leaks)	X			
Check filter insert of external oil mist filter (if existent)	X			
Change filter insert of external oil mist filter (if existent)		X		
Change operating fluid		X		
Disassemble casing, sight glass and pumping system, clean casing outside (without cleaning agent) and change casing seal		X		
Clean gas ballast valve and silencer nozzle		X		
Clean the motor fan cap		X		
Clean or change vacuum safety valve			X (PV)	
Clean or change exhaust valves			X (PV)	
Change vanes and hydraulic vane				X (PV)
Check or change coupling				X (PV)
Disassemble the pump, clean and exchange seals and wearing parts (overhaul): ⇒ Valves, compression springs and sight glass ⇒ Vanes ⇒ Valve flap of the gas ballast valve ⇒ Silencer nozzle				X (PV)

Depending on the process, the required replacement intervals for lubricants and the intervals for inspection, maintenance and overhaul may be shorter than the guide values specified in the table. Consult with Pfeiffer Vacuum Service if necessary.

7.2 Changing the operating fluid

The service life of the operating fluid is dependent on the application area for the pump. It must be changed if:

- The specified ultimate pressure is no longer reached
- The operating fluid in the sight glass is visibly contaminated, milky, or cloudy
- The operating fluid is thermally aged, identifiable by its color ID value (applies to mineral oils only).



Depending on the applications, Pfeiffer Vacuum recommends determining the exact service life of the operating fluid during the first year of operation.

The replacement interval may vary from the guide value specified by Pfeiffer Vacuum depending on the thermal and chemical loads, and the accumulation of suspended particles and condensation in the operating fluid.



WARNING

Hot operating fluid!

Danger of burns when draining due to contact with skin.

- Wear suitable protective clothing.
- Use a suitable collecting vessel.



WARNING

Operating fluid may contain toxic substances from the pumped media!

Danger of poisoning from the emission of harmful substances from the operating fluid.

- Wear suitable protective clothing and respirators.
- Dispose of operating fluid according to the local regulations



Request safety data sheets for operating fluids and lubricants

from Pfeiffer Vacuum or download at www.pfeiffer-vacuum.com.

- Dispose of operating fluid according to the local regulations.

Draining the operating fluid

- Turn off the vacuum pump, vent to atmospheric pressure and allow to cool.
- Unscrew operating fluid filler screw 198.
- Unscrew operating fluid drain screw 198a.
- Drain the operating fluid while still quite hot;
 - to empty the pump fully, tip it forward slightly.

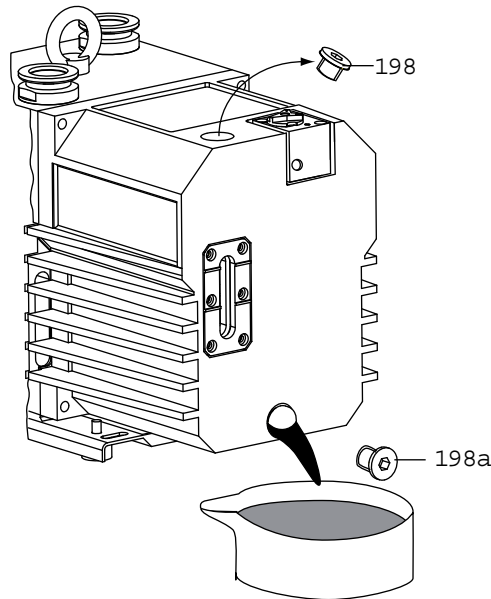

Fig. 14: Draining the operating fluid

- Screw in operating fluid drain screw 198a; pay attention to O-ring.
- Screw in operating fluid filler screw 198; pay attention to O-ring 306.
- Allow pump to run for a maximum of 5 seconds with the vacuum flange open.
- Drain off remaining operating fluid.
 - In case of serious contamination, the operating fluid will have to be changed several times (flushing):
- Screw in operating fluid drain screw 308; pay attention to O-ring 310.
- Fill up with operating fluid and check the filling level (see p. 16, chap. 5.5).
- Screw in operating fluid filler screw 198; pay attention to O-ring 306.

Determining the level of deterioration

- The level of deterioration of operating fluid P3 can be determined for clean processes with the colour scale (in accordance with DIN 51578); supplementary sheet PK 0219 BN on request or at www.pfeiffer-vacuum.com.
- Suck off operating fluid from the pump through the operating fluid filler opening.
- Fill the specimen in a test tube or some similar vessel and test by holding against the light.
- Where discolouration is red brown (equivalent to 5 on the scale) change operating fluid at the latest.

Flushing and cleaning

If the interior of the pump is heavily contaminated with process residues, we recommend performing several changes of operating fluid to flush away the contamination:

- Operate the pump with the gas ballast open until the pump has warmed up.
- Drain the operating fluid again and check for contamination, flush again if necessary.
- Take off the cap and clean the sight glass and pump system externally (without cleaning agent).
- Replace the filter elements in the accessories.
- Screw in operating fluid drain screw 308; pay attention to O-ring 310.
- Fill up with operating fluid and check the filling level (see p. 16, chap. 5.5).
- Screw in operating fluid filler screw 198; pay attention to O-ring 306.

7.3 Changing the kind of operating fluid

When filling up, topping up or changing the operating fluid, always use the type of operating fluid indicated on the pump type plate. If, for example, amended process conditions require the use of a different operating fluid, the fluid can be changed as follows:



NOTICE

Changing the type of operating fluid.

A change of operating fluid type can be only be made between mineral (P3) and synthetic operating fluid (D1). It is not possible to change from these two types to F4/F5 or the other way round!

→ For the two flushing processes and final fill, the pump needs to be filled up three times with fresh operating fluid, and this is the amount of operating fluid required.

- Perform two flushing processes with the new operating fluid.
- Clean any accessories present such as the ONF/OME or ORF/ODK and replace their filter elements; pay attention to whether more operating fluid is required.
- Fill the pump for the final time with the third filling.
- Note down the current type of operating fluid in an appropriate place on the pump (preferably on the type plate).

7.4 Cleaning the gas ballast valve

Gas ballast valve, standard version

The gas ballast valve 42 will only be contaminated when airborne dust is in the intake air.

Dismantling

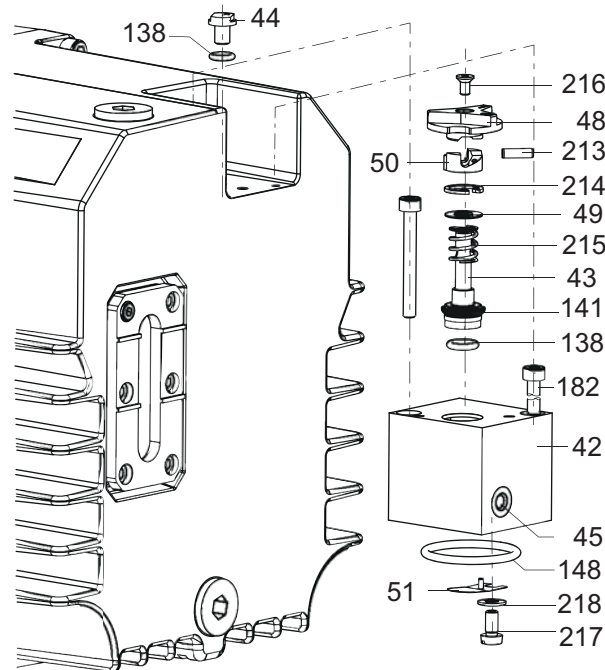

Fig. 15: Gas ballast valve

42	Valve housing	50	Cam plate	213	Cylinder text
43	Valve tappet	51	Plate spring	214	Circlip
44	Silencer nozzle	138	O-ring	215	Compression spring
45	Flushing gas nozzle (Uno 30 M only)	141	O-ring	216	Countersink screw
48	Button	148	O-ring	217	Screw
49	Washer	182	Screws	218	Washer

- Unscrew the screws 182.
- Remove valve housing 42 from the cap; note the o-ring 148.
- Turn button 48 to the "open" position.
- Unscrew screw 216 and remove button 48.
- Pull the valve tappet 43 out of the valve housing 42 until the cylinder pin 213 can be removed.
- Use suitable pliers to take out the cam plate 50 and the circlip 214; note washer 49 and compression spring 215.
- Remove valve tappet 43 from valve housing 42, note o-ring 138/141.
- Unfasten screw 217 and remove plate spring 51; note washer 218.
- Clean all parts and examine for wear.
- Replace wearing parts in accordance with the maintenance kit.

Assembling

- **Assembling** is carried out in reverse order.
- Note the installation position of the plate spring 51 (curvature to the housing);
 - note the correct alignment and screw on under pre-tension.
- Tighten screws 182 uniformly to **2.5 Nm**.

Cleaning or changing the silencer

The silencer is a nozzle 44 inside the pump housing and cannot be altered; when dirty it should either be cleaned or replaced.

Dismantling

- Carry out preliminary work as described before.
- Remove the gas ballast valve housing 42 from the cap; note o-ring 148.
- Unscrew silencer nozzle 44 with o-ring 138, clean or replace as necessary.

Assembly

- **Assembling** is carried out in reverse order.
- Tighten screws 182 uniformly to **2.5 Nm**.

8 Decommissioning

8.1 Shutting down for longer periods

Before shutting down the pump, observe the following procedure and adequately protect the pump system against corrosion:

- Switch off pump.
- Change operating fluid.
- Start the pump and allow the pump to warm up.
- Switch off the pump.
- Fill up the pump with new operating fluid to the top edge of the sight glass.
- Close vacuum flange and exhaust flange with locking caps.
- Store the pump only dry and dust-free indoors within the specified environmental conditions.
 - In rooms with moist or aggressive atmospheres, the pump must be airproof shrink-wrapped in a plastic bag together with a bag of desiccant.
 - After storage periods longer than two years, it is recommended to carry out maintenance and change the operating fluid before using the pump.
- Do not store pump in the vicinity of machines, lanes, etc., because strong vibrations can damage the rotor bearings.

8.2 Re-starting



Emission of operating fluid!

Danger of the operating fluid being emitted at the exhaust flange if overfilled.

- Drain the operating fluid to the normal level before restarting the pump.



CAUTION

Re-starting

The serviceability of the operating fluid without operation is a maximum of 2 years. Before restarting after a shut-down of **2 years or longer**, carry out the following work.

- Replace the operating fluid.
- Replace the elastomer parts, with reference to DIN 7716 and the manufacturer's specifications.
- Follow the maintenance instructions and inform Pfeiffer Vacuum.

8.3 Disposal

Products or parts thereof (mechanical and electrical components, operating fluids, etc.) may cause environmental burden.

- Safely dispose of the materials according to the locally applicable regulations.

9 Malfunctions

Please note the following instructions should the pump malfunction:



CAUTION

Hot surface!

Danger of burns if hot parts are touched. The surface temperature of the pump may rise above 105 °C in case of malfunction.

→ Carry out work on the pump only after it has cooled to a safe temperature.



NOTICE

Motor overload!

Depending on the malfunction (e.g. blocking during cold start), the motor may not be sufficiently protected by the built-in thermal protection switch from damage through overheating.

→ Implement an additional network safety device.

9.1 Rectifying malfunctions

Problem	Possible causes	Remedy
Pump will not start up	No mains voltage or voltage does not correspond to the motor data	Check mains voltage and mains fuse protection; check motor switch
	Pump temperature too low	Warm up pump
	Thermal protection switch has responded	Detect and fix cause of overheating; allow pump to cool off if necessary
	Pump system dirty	Clean pump; contact Pfeiffer Vacuum Service if necessary
	Pump system damaged	Clean and overhaul pump; contact Pfeiffer Vacuum Service if necessary
	Motor defective	Replace motor
Pump switches off after a while after being started	Thermal protection switch of the motor has responded	Detect and fix cause of overheating; allow motor to cool off if necessary
	Mains fuse protection triggered due to overload (e.g. cold start)	Warm up pump
	Exhaust pressure too high	Check opening of exhaust line and exhaust accessories
Pump does not attain ultimate pressure	Measurement reading is false	Check gauge, check final pressure without installation connected
	Pump or connected accessories are dirty	Clean pump and check components for contamination
	Operating fluid dirty	Operate pump for a longer period with gas ballast valve open or change operating fluid
	Leak in system	Repair leak
	Operating fluid filling level too low	Top off operating fluid
	Pump damaged	Contact Pfeiffer Vacuum Service
Pumping speed of pump too low	Intake line not well-dimensioned	Keep connections as short as possible and see that cross-sections are sufficiently dimensioned
	Exhaust pressure too high	Check opening of exhaust line and exhaust accessories
Loss of operating fluid	Swivel gasket leaky	Check tightness; replace gasket if necessary
	Operational loss of operating fluid	If necessary, install oil mist filter and oil return unit
Unusual operating noises	Silencer dirty	Clean or replace the silencer; (see p. 27, chap.)
	Damage to the pump system	Clean and overhaul pump; contact Pfeiffer Vacuum Service if necessary
	Motor bearing defective	Replace motor; contact Pfeiffer Vacuum Service if necessary



NOTICE

Service work should be carried out by a qualified person only!

Pfeiffer Vacuum is not liable for any damage to the pump resulting from work carried out improperly.

→ Take advantage of our service training programs; additional information at www.pfeiffer-vacuum.com.

→ Please state all the information on the pump rating plate when ordering spare parts.

10 Service

Pfeiffer Vacuum offers first-class service!

- Maintenance/repairs on site by Pfeiffer Vacuum field service
- Maintenance/repairs in a nearby service center or service point
- Fast replacement with exchange products in mint condition
- Advice on the most cost-efficient and quickest solution

Detailed information and addresses at: www.pfeiffer-vacuum.com (Service).

Maintenance and repairs in Pfeiffer Vacuum ServiceCenter

The following steps are necessary to ensure a fast, smooth servicing process:

- ➔ Download the forms "Service Request" and "Declaration on Contamination".¹⁾
- ➔ Fill out the "Service Request" form and send it by fax or e-mail to your Pfeiffer Vacuum service address.
- ➔ Include the confirmation on the service request from Pfeiffer Vacuum with your shipment.
- ➔ Fill in the contamination declaration and enclose it in the shipment (required!).
- ➔ Dismantle all accessories.
- ➔ Drain operating fluid/lubricant.
- ➔ Drain cooling medium, if used.
- ➔ Send the pump or unit in its original packaging if possible.

Sending of contaminated pumps or devices

No units will be accepted if they are contaminated with micro-biological, explosive or radioactive substances. "Hazardous substances" are substances and compounds in accordance with the hazardous goods directive (current version). If pumps are contaminated or the declaration on contamination is missing, Pfeiffer Vacuum performs decontamination at the shipper's expense.

- ➔ Neutralise the pump by flushing it with nitrogen or dry air.
- ➔ Close all openings airtight.
- ➔ Seal the pump or unit in suitable protective film.
- ➔ Return the pump/unit only in a suitable and sturdy transport container and send it in while following applicable transport conditions.

Service orders

All service orders are carried out exclusively according to our repair conditions for vacuum units and components.

¹⁾ Forms under www.pfeiffer-vacuum.com

11 Spare parts

11.1 Spare parts packages

The spare parts packages listed here are only applicable for standard models.

Please state all information on the rating plate when ordering spare parts. Other spare parts than those described in this manual must not be used without the agreement of Pfeiffer Vacuum.

Spare parts package	Pump type	Revision index	Article no.	Parts according to the exploded view on the following page
Set of seals	DUO 20 M DUO 20 MC		PK E30 008 -AT	76, 112, 113, 138, 141, 144, 147, 148, 149, 152, 154, 155, 156, 158, 162.
Maintenance kit	DUO20 M DUO 20 MC		PK E31 007 -T	144, 162.
Discharge valves	DUO 20 M DUO 20 MC		PK E38 006 -T PK E38 005 -T	7, 8, 9, 10.
Overhaul kit	DUO 20 M		PK E32 011 -T	PK E30 008 -T, 7, 8, 9, 10, 32, 44, 51, 102, 106, 110, 114, 193, 195.
	DUO 20 MC		PK E32 013 -T	PK E30 008 -T, 7, 8, 9, 10, 32, 44, 51, 102, 106, 110, 114, 193, 195.
Vacuum safety valve	DUO 20M DUO 20 MC	from "E"	PK E34 007 -AT	30, 32, 34, 35, 96, 101, 106, 108, 147, 152, 154, 158, 188, 204, 207, 208, 220, 250.
Pumping system, complete and tested with P3	DUO 20 M	from "E"	PK E33 020 -AT	4.1 without vacuum safety valve
Pumping system, complete and tested with D1	DUO 20 M	from "E"	PK E33 023 -AT	4.1 without vacuum safety valve
Pumping system, complete and tested with F4	DUO 20 M	from "E"	PK E33 021 -AT	4.1 without vacuum safety valve
Pumping system, complete and tested with F4	DUO 20 MC	from "E"	PK E33 022 -AT	4.1 without vacuum safety valve
Discharge valve	DUO 20 M DUO 20 MC		PK E35 006 -T	102, 104, 154, 158, 184, 188.
Coupling kit	DUO 20 M	without	PK E36 010-T	18, 20, 22, 24, 27, 155, 208.
		as from "A"	PK E36 009 -T	18, 20, 22, 24, 155, 208.
	DUO 20 MC	as from "A"	PK E36 013 -T	18, 20, 22, 24, 155, 183, 185, 208.

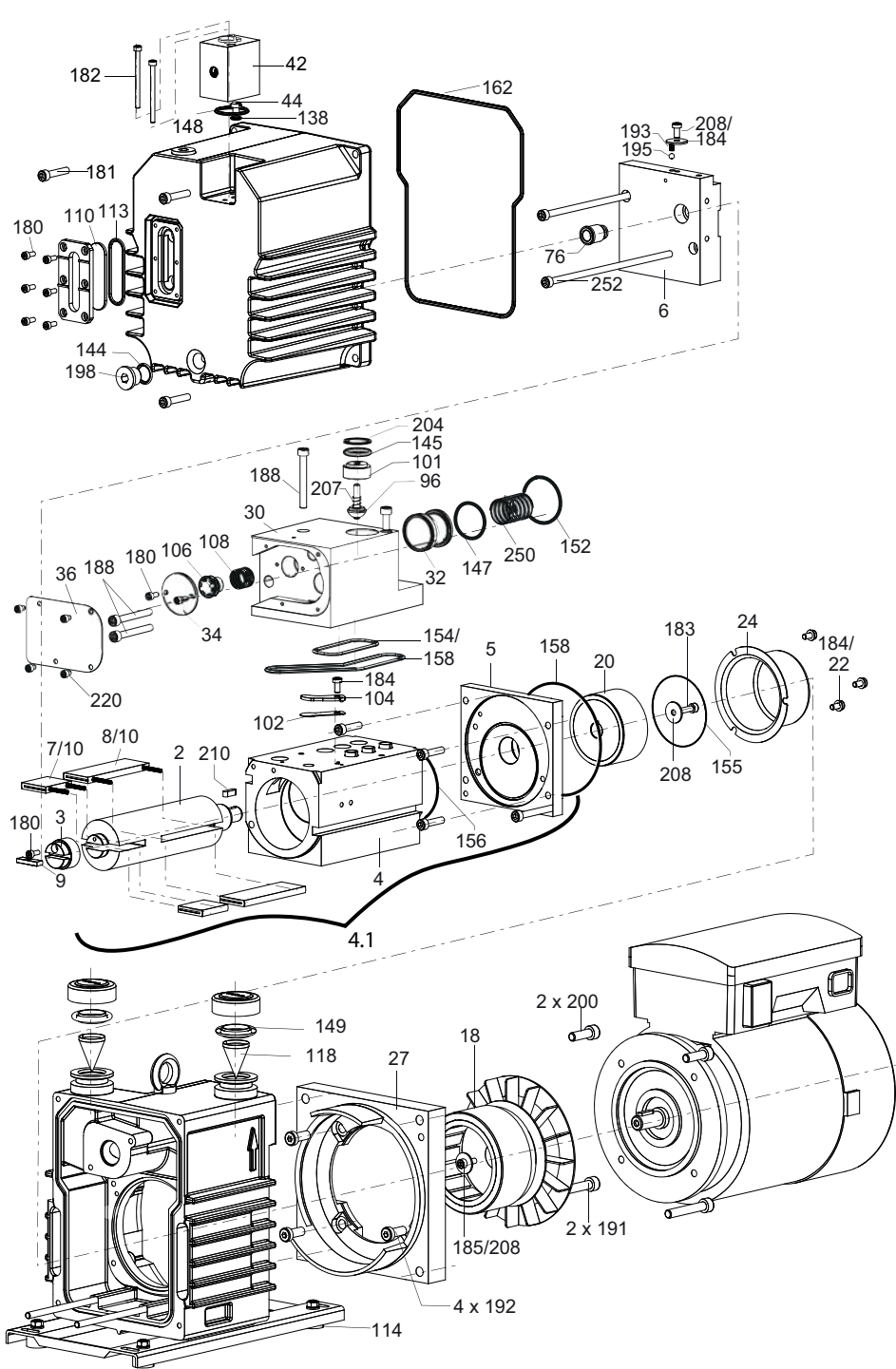

- 2 Rotor
- 3 Hydraulic pump
- 4 Pump cylinder
- 5 Support plate
- 6 Bearing cover
- 7 Vanes, rough stage
- 8 Vanes, medium stage
- 9 Hydraulic vane
- 10 Compression spring, vanes
- 18 Magnetic coupling, drive side
- 20 Magnetic coupling, pump side
- 22 Washer
- 24 Can
- 27 Intermediate flange for motor
- 30 Housing, vacuum safety valve
- 32 Valve plate, vacuum safety valve
- 34 Valve cover, vacuum safety valve
- 35 Strainer
- 36 Cover plate
- 42 Gas ballast valve housing (further parts see Section. 7.4.)
- 44 Silencer nozzle
- 51 Plate spring
- 76 Rapid action coupling
- 96 Exhaust valve, (stage 1)
- 101 Punched disk
- 102 Valve plate
- 104 Valve trap
- 106 Hydraulic piston
- 108 Compression spring
- 110 Sight glass
- 113 O-ring
- 114 Rubber foot
- 116 Flange
- 138 O-ring
- 141 O-ring
- 144 O-ring
- 145 O-ring
- 147 O-ring
- 148 O-ring
- 149 O-ring
- 152 O-ring
- 154 O-ring
- 155 O-ring
- 156 O-ring
- 158 O-ring
- 162 O-ring
- 180 Allan head screw
- 183 Allan head screw
- 184 Allan head screw
- 185 Allan head screw
- 188 Allan head screw
- 193 Compression spring, over pressure valve
- 195 Ball
- 198 Operating fluid drain screw
- 204 Circlip
- 207 Compression spring
- 208 Washer
- 220 Screw
- 250 Compression spring
- 252 Allan head screw

Fig. 16: Exploded view DUO 20 M/MC

12 Accessories

Further detailed accessories are contained in the Pfeiffer Vacuum printed or Online Catalogue.

Designation	Duo 20 M
SAS 25, dust separator, DN 25 ISO-KF, polyester filter	PK Z60 508
KAS 25 L, condensate separator for pumping speeds up to 35 m ³ /h	PK Z10 033
OME 25 ML, oil mist filter for pumping speeds of up to 30 m ³ /h	PK Z40 158
ZFO 025, zeolite trap	PK Z70 006
FAK 025, activated carbon filter	PK Z30 006
KLF 025, cold trap	PK Z80 006
URB 025, catalytic trap, 230 V	PT U10 760
URB 025, catalytic trap, 115 V	PT U10 761
Oil pressure switch for Duo 5/10/20 M and Penta 20/35	PK 196 484 -T
PTC-resistor tripping device	P 4768 052 FQ
Operations monitoring unit 3 for Duo 1.6/3/6/11 and Duo 5/10/20 M	PK 196 141 -T
Operations monitoring unit 2 for Duo 1.6/3/6/11 and Duo 5/10/20 M	PK 196 142 -T
Operations monitoring unit 1 for Duo 1.6/3/6/11 and Duo 5/10/20 M	PK 196 157 -T
Oil return unit ODK from OME 16 M to Duo 5 M, from OME 25 M to Duo 10 M, Duo 20 M	PK 196 172 -T
Elbow union for gas ballast valve	P 4131 018
P3, mineral oil, 1 l	PK 001 106 -T
P3, mineral oil, 5 l	PK 001 107 -T
P3, mineral oil, 20 l	PK 001 108 -T

Designation	Duo 20 MC
KAS 25 C, condensate separator, corrosive version for pumping speeds up to 35 m ³ /h	PK Z10 406
ONF 025 C, oil mist filter, corrosive gas version up to 24 m ³ /h	066849
KLF 025, cold trap	PK Z80 006
Oil pressure switch for Duo 5/10/20 M and Penta 20/35	PK 196 484 -T
PTC-resistor tripping device	P 4768 052 FQ
Operations monitoring unit 3 for Duo 1.6/3/6/11 and Duo 5/10/20 M	PK 196 141 -T
Operations monitoring unit 2 for Duo 1.6/3/6/11 and Duo 5/10/20 M	PK 196 142 -T
Operations monitoring unit 1 for Duo 1.6/3/6/11 and Duo 5/10/20 M	PK 196 157 -T
Oil return unit from OME 25 M, 25 ML, 25 MXL	PK 196 177 -T
Elbow union for gas ballast valve	P 4131 018
F4, Perfluoropolyether, 0.25 l	PK 005 885 -T
F4, Perfluoropolyether, 0.5 l	PK 005 886 -T
F4, Perfluoropolyether, 1 l	PK 005 887 -T

13 Technical data and dimensions

13.1 General

- Recommendations of PNEUROP committee PN5
- ISO 21360; 2007: "Vacuum technology - Standard methods for measuring vacuum-pump performance - General description"

Conversion table: pressure units

	mbar	bar	Pa	hPa	kPa	Torr mm Hg
mbar	1	$1 \cdot 10^{-3}$	100	1	0.1	0.75
bar	1000	1	$1 \cdot 10^5$	1000	100	750
Pa	0.01	$1 \cdot 10^{-5}$	1	0.01	$1 \cdot 10^{-3}$	$7.5 \cdot 10^{-3}$
hPa	1	$1 \cdot 10^{-3}$	100	1	0.1	0.75
kPa	10	0.01	1000	10	1	7.5
Torr mm Hg	1.33	$1.33 \cdot 10^{-3}$	133.32	1.33	0.133	1

$$1 \text{ Pa} = 1 \text{ N/m}^2$$

Conversion table: gas throughput units

	mbar·l/s	Pa·m ³ /s	sccm	Torr·l/s	atm·cm ³ /s
mbar·l/s	1	0.1	59.2	0.75	0.987
Pa·m ³ /s	10	1	592	7.5	9.87
sccm	$1.69 \cdot 10^{-2}$	$1.69 \cdot 10^{-3}$	1	$1.27 \cdot 10^{-2}$	$1.67 \cdot 10^{-2}$
Torr·l/s	1.33	0.133	78.9	1	1.32
atm·cm ³ /s	1.01	0.101	59.8	0.76	1

13.2 Technical data

Parameter	Duo 20 M	Duo 20 MC
Flange (in)	DN 25 ISO-KF	DN 25 ISO-KF
Flange (out)	DN 25 ISO-KF	DN 25 ISO-KF
Pumping speed at 50 Hz	20 m ³ /h	20 m ³ /h
Pumping speed at 60 Hz	24 m ³ /h	24 m ³ /h
Ultimate pressure with gas ballast	4 · 10 ⁻³ hPa	7 · 10 ⁻³ hPa
Ultimate pressure without gas ballast	2 · 10 ⁻³ hPa	4 · 10 ⁻³ hPa
Exhaust pressure, min.	250 hPa	250 hPa
Exhaust pressure, max.	1500 hPa	1500 hPa
Rotation speed at 50 Hz	1500 min ⁻¹	1500 min ⁻¹
Rotation speed at 60 Hz	1800 min ⁻¹	1800 min ⁻¹
Leak rate safety valve	≤ 1 · 10 ⁻⁵ Pa m ³ /s	≤ 1 · 10 ⁻⁵ Pa m ³ /s
Leak rate magnetic coupling		≤ 1 · 10 ⁻⁶ Pa m ³ /s
Emission sound pressure level without gas ballast at 50 Hz	≤ 57 dB (A)	≤ 57 dB (A)
Ambient temperature	12-40 °C	12-40 °C
Protection category	IP54	IP54
Rated power 50 Hz	0.75 kW	0.75 kW
Rated power 60 Hz	0.90 kW	0.90 kW
Motor version	1-phase Motor	1-phase Motor
Mains requirement: voltage 50 Hz	100-110 (± 5 %) V	100-110 (± 5 %) V
Mains requirement: voltage 60 Hz	100-120 (± 5 %) V	100-120 (± 5 %) V
Mains requirement: voltage (selectable)	200-230, 50 Hz; 200-240, 60 Hz V	200-230, 50 Hz; 200-240, 60 Hz V
Mains cable	Yes	Yes
Shipping and storage temperature	-25-+55 °C	-25-+55 °C
Operating fluid filling	1.1 l	1.1 l
Weight	44 kg	44 kg
Cooling method, standard	Air	Air

Typical ultimate pressure according to PNEUROP

Parameter	Duo 20 M
Flange (in)	DN 25 ISO-KF
Flange (out)	DN 25 ISO-KF
Pumping speed at 50 Hz	20 m ³ /h
Pumping speed at 60 Hz	24 m ³ /h
Ultimate pressure with gas ballast	4 · 10 ⁻³ hPa
Ultimate pressure without gas ballast	2 · 10 ⁻³ hPa
Exhaust pressure, min.	250 hPa
Exhaust pressure, max.	1500 hPa
Rotation speed at 50 Hz	1500 min ⁻¹
Rotation speed at 60 Hz	1800 min ⁻¹
Leak rate safety valve	≤ 1 · 10 ⁻⁵ Pa m ³ /s
Emission sound pressure level without gas ballast at 50 Hz	≤ 55 dB (A)
Ambient temperature	12-40 °C
Protection category	IP55
Rated power 50 Hz	0.55 kW
Rated power 60 Hz	0.66 kW
Motor version	3-phase Motor
Mains requirement: voltage 50 Hz	220-240/380-420 (± 5 %) V
Mains requirement: voltage 60 Hz	250-277/440-480 (± 5 %) V
Switch	No
Mains cable	No
Shipping and storage temperature	-25-+55 °C
Operating fluid filling	1.1 l
Weight	33 kg
Cooling method, standard	Air

Typical ultimate pressure according to PNEUROP

13.3 Dimensions

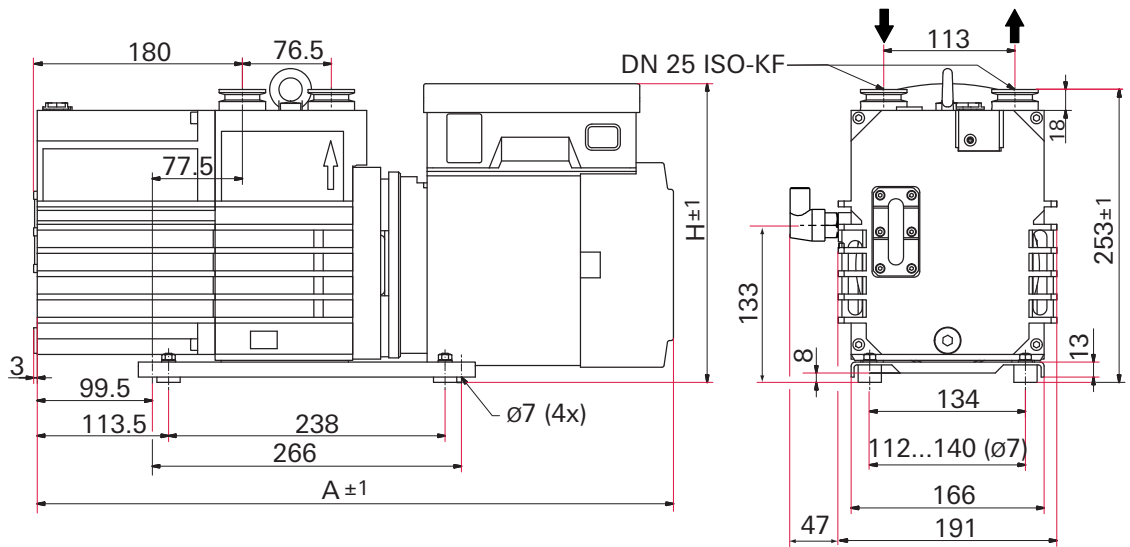

Fig. 17: DUO 20 M

	Pump with three phase motor	Pump with single phase motor
A	545 mm	551 mm
H	212 mm	262 mm



Declaration of conformity

We hereby declare that the product cited below satisfies all relevant provisions according to the following **EC directives**:

- **Machinery 2006/42/EC (Annex II, no. 1 A)**
- **Electromagnetic Compatibility 2014/30/EU**
- **Restriction of the use of certain Hazardous Substances 2011/65/EU**

The agent responsible for compiling the technical documentation is Mr. Sebastian Oberbeck, Pfeiffer Vacuum GmbH, Berliner Straße 43, 35614 Asslar.

DuoLine™
DUO 20 M/MC

Harmonised standards and national standards and specifications which have been applied:

DIN EN ISO 12100 : 2010	DIN EN 61010-1 : 2010	DIN EN 61000-6-3 : 2007 + A1: 2011
DIN EN 1012-2 : 2011-12	DIN EN 61000-6-1 : 2007	DIN EN 61000-6-4 : 2007 + A1: 2011
DIN EN ISO 13857 : 2008	DIN EN 61000-6-2 : 2006	DIN EN ISO 2151 : 2: 2008
ISO 21360-1, 2 : 2012		

Signature:

Pfeiffer Vacuum GmbH
Berliner Straße 43
35614 Asslar
Germany

(Dr. Ulrich von Hülsen)
Managing Director

2017-02-17

VACUUM SOLUTIONS FROM A SINGLE SOURCE

Pfeiffer Vacuum stands for innovative and custom vacuum solutions worldwide, technological perfection, competent advice and reliable service.

COMPLETE RANGE OF PRODUCTS

From a single component to complex systems:

We are the only supplier of vacuum technology that provides a complete product portfolio.

COMPETENCE IN THEORY AND PRACTICE

Benefit from our know-how and our portfolio of training opportunities!

We support you with your plant layout and provide first-class on-site service worldwide.

Are you looking for a
perfect vacuum solution?
Please contact us:

Pfeiffer Vacuum GmbH
Headquarters • Germany
T +49 6441 802-0
info@pfeiffer-vacuum.de

www.pfeiffer-vacuum.com

PFEIFFER  **VACUUM**