

MAINTENANCE INSTRUCTIONS

EN

Translation of the original instructions

PASCAL SERIES

Rotary vane pumps 5 to 21 m³/h



Rotary vane pumps

Dear customer,

This Maintenance instructions is intended for customers of the Pfeiffer Vacuum Company. It describes the product maintenance operations which can be performed by the user on the product concerned. This documentation must be used together with the operating manual for the product of the same name.



Maintenance	
Safety instructions for maintenance	3
Tools and consumable products	4
Replacement of external shaft seal.....	7
Disassembling the pump.....	8
Cleaning components.....	13
Replacement of shaft seals	14
Reassembling the pump.....	15
Service	19
Nomenclature	
Spare parts lists.....	N - 1 à N - 23

Translated from original version

CAUTION

Indicates a potentially hazardous situation which, if not avoided, could result in property damage.

 **CAUTION**

Indicates a potentially hazardous situation which, if not avoided, could result in moderate or minor injury. It may also be used to alert against unsafe practices.

 **WARNING**

Indicates a potentially hazardous situation which, if not avoided, could result in death or severe injury.

 **DANGER**

Indicates an imminently hazardous situation that, if not avoided, will result in death or severe injury (extreme situations).

Before switching on the product, study operating instructions and make sure you follow the safety instructions it gives. You can recognise these by the 'Caution', 'Warning' and 'Danger' symbols.
Good practice tips and manufacturer's recommendations are in a grey box.

Safety instructions for maintenance

General precautions

For normal operation, the maintenance of 5 to 21 m³/h series pumps only require regular oil changes (*see Operating instructions*).

WARNING

Maintenance must be performed by a skilled maintenance operator trained in the relevant health and safety aspects (EMC, electrical hazards, chemical pollution, etc.).
Isolate the product from all energy sources (mains electricity, compressed air, etc.) before starting work.

DANGER



- Certain gases can become corrosive and toxic after decomposing when trapped in oil. Always wear protective gloves when handling used and dirty pump oil, drain it into a closable container, and do not breathe the oil fumes. Always use fully self-contained breathing apparatus.
- During pump removal, draining or maintenance operator could be in contact with process residues which could cause severe injury or death. Ask your safety department for instructions according to the local regulations.

We recommend:

- To purge the pumping installation with dry nitrogen.
- To wear gloves, protective glasses, breathing mask or any appropriated safety equipment.
- To ventilate the premises well.
- Not to eliminate maintenance waste via standard disposal channels. Have it destroyed by a qualified company if necessary.
- To install the inlet and exhaust blanking plates, these accessories are delivered with the pump.
- Decontamination – product dismantling
According to the regulations 2012/19/EU about Waste of electrical and electronical equipments, and 2011/65/EU about Restriction of Hazardous substances, the manufacturer provides a recycling paid service for the end of-life of electrical and electronic equipment.
Any obligation of the manufacturer to take back such equipment shall apply only to complete not amended or modified equipment, using Pfeiffer Vacuum original spare parts, delivered by Pfeiffer Vacuum, containing i.e. all its components and sub-assemblies.
This obligation will not cover the shipping cost to a Pfeiffer Vacuum taking back facility.
- Whenever you return the product to an repair service center, please make sure you follow the Service procedure and fill in the declaration of contamination found on our website.

WARNING

Insufficient tightness after servicing could result in chemical hazards. Always perform a leak test after maintenance.

Tools and consumable products

Special precautions

Read the safety instructions at the beginning of the maintenance chapter. Before disassembling the pump, drain it (see *Operating instructions*). All the seals and faulty parts should be replaced: provide a seal kit or an overhaul kit.

Spare parts

For fasted service, specify the following when ordering:

- Pump type.
- Serial number (on pump label).
- Part number (see list at end of operating instructions).

Overhaul kits containing the most frequently used parts are always available at our sales outlets. Be sure to use these kits so you will have all the parts necessary.

Seal kit

This kit contains all the seals on the pump which must be replaced at each complete disassembly.

Pumps	1005	1015	2005	2010	2015	2021
I	–	105515	103912			
SD / SDI	103911	105515	103911			
C1	104975					
C2	–	104975				

Keep this kit in a dry place, away from heat and light (sunlight and ultraviolet light), in order to prevent any hardening of the elastomers (see AFNOR standards: "storage conditions for vulcanized elastomer based products" - FD T.46 022).

Overhaul kit

In addition to the seal kit, this kit contains a set of spare parts to perform overhaul on the pump for a two year period, under normal operating conditions.

Pumps	1005	1015	2005	2010	2015	2021
I	–	104643	103906	103907	103908	103909
SD / SDI *	104622	104643	103902	103903	103904	103905
C1	104617	104619	104976	104977	104978	104979
C2	–	–	–	104614	104615	104616

* For SDI pump with no flanged stator, use a major kit P/N 108308.

The pumps are equipped with :

- a **shouldered not chromed ring (36)** for I, SD and SDI models with serial number < AM656245
- a **shouldered chromed ring (36)** for I, SD and SDI models with serial number ≥ AM656245
- a **shouldered chromed ring (36)** for C1 and C2 models.

The **shouldered not chromed ring** is a spare part that must be replaced with a chromed ring.

The **shouldered chromed ring** needn't systematically to be changed.

Spare parts (cont'd)

Vane kits for 2-stage pumps

This kit contains only vanes and springs in order to maintain several pumps of the same model (see table here after).

Pumps	2005	2010	2015	2021
LP stage vane kit	108417	108396	108397	108398
Vane / Spring (quantity)	20 / 22	20 / 42	20 / 62	20 / 62
HP stage vane kit*	108417	108399	108399	108399
Vane / Spring (quantity)	20 / 22	20 / 22	20 / 22	20 / 22

* except models C1 and C2.

Pumps	2005	2010	2015	2021
Oil vane pump kit**	108407 (10 vanes)			

** except models SD and C2.

External shaft seal replacement kit (parts for shaft passage tightness on motor side)

This kit contains all the parts which must be replaced in the event of a leak on the shaft on the motor side.

Pump models	P/N
All pumps	065612

Screw kit

This kit contains all screws and washers for the range of Pascal's pump.

Pump models	P/N
All pumps	104919

Capacitor kit for single-phase motors

For safety reasons, the manufacturer recommends that single-phase motors be properly maintained. Although there is only an extremely small risk of flammability, you are advised to replace the capacitors and/or the motor in the following cases:

Single-phase motor with ID number < 110000 :

- **replace the motor immediately** by ordering a new motor.
- **then, every 5 years**, replace the capacitors and the relays by ordering a kit.

Single-phase motor with ID number > 110000 :

- **every 5 years**, replace the capacitors and the relays by ordering a capacitor kit.
- **after 15 years**, replace the motor by ordering a new motor.



Single-phase motor to maintain		Capacitor/relay kit		New equipped motor
ID number < 110000	ID number > 110000	P/N	Description	Ordering P/N
103749	110944	111695	Capacitors (300µF, 20µF) + relay	108694
103750	110913			108696
104734	110600			108697
105132	110946			108698
106442	110947			108699S
107876	110948	111701	Capacitors (300µF, 25µF) + relay	108802S



The procedure for replacing capacitors and relays is provided with the capacitor kit.

Tools and consumable products (cont'd)



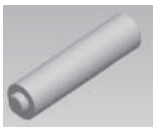

Specific tools

Tools kit This kit contains the usefull tools to disassemble and reassemble the shaft seals in the different flanges and flanged stators (see table below).

Pump models	P/N
All pumps	112397

		HP and LP no flanged stator (<i>plan D</i>)	HP flanged stator (<i>plan C</i>)	LP flanged stator (<i>plan C</i>)
Lip seal assembly mandrel		A462651	A462651	A462651
Protective sleeve		A463545	A463545	A463545
Lip seal disassembly mandrel		-	-	A462649

Recommended tools

- Two 5.5 x 100 flat screwdrivers 
- Thin spanner: 10 mm on face 
- Male hexagonal wrench: 2.5 - 3 - 4 - 5 - 12 mm 
- 12 mm female hexagonal wrench 

Replacement of external shaft seal

In the event of an external oil leak on the pump, it is necessary to change the external shaft seal on the motor side (see page N – 4).

You will need:

- a front seal replacement kit (see page 5),
- a screwdriver,
- a 3, 4 and 5 mm Allen wrench,
- a lip seal mandrel (see page 6).

Stop the pump and disconnect the power cord motor.

Disconnect the pump from the installation to which it is connected.

If possible, position the pump vertically, with the motor at the top, resting on the front side of the oil case; in this position, it is not necessary to drain the oil case. Otherwise, disassemble the pump in the horizontal position, resting it on its base, after it has been drained (see **Operating instructions**).

Disconnect the motor by unscrewing the 4 fastening screws, simultaneously and alternately.

Remove the motor vertically.

Unscrew the fan fastening screw. Remove the fan, the key and the support washer.

With a screwdriver, remove the shouldered ring (36) and its O-ring (35).

Unscrew the two seal-holder fastening screws (37, 38) and remove the seal-holder (39).

Remove the seal (40) from the seal-holder as described on page 14 (picture 1) and discard it.

Clean the metal parts. Inspect the wearing side of the shaft sleeve: after cleaning, the sleeve may show a perfectly normal trace of rubbing (caused by polishing). Should the sleeve show any signs of indentation or grooves, it must be replaced.

Use new parts from the external shaft seal replacement kit or from the overhaul kit.

Reassemble the lip seal (40) in its housing as described on page 14.

Reinsert the new O-ring (41a) on the seal-holder (39).

Insert the shaft sleeve inside the shouldered ring (36).

Engage the reassembled seal-holder on its axis and screw onto the frame.

Insert the O-ring (35) in the shaft sleeve. Position the support washer. Then, install the key, reassemble the fan and the motor in the reverse order of disassembly.

Immediately order an external shaft seal replacement kit or an overhaul kit (see page 5).

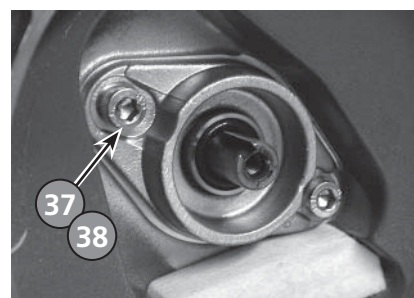
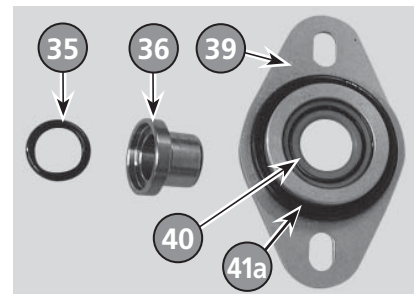

Disassembling the pump

Removing pump from system

Study the general precautions listed on Maintenance chapter page 3.

The following steps are necessary to protect the pump as far as possible from the effects of corrosion:

- Flush pump with a neutral gas (dry nitrogen) during half an hour to prevent toxic or corrosive gases accumulating in the pump.
- C2 Model: Disconnect the nitrogen lines to the pump.
- Disconnect the pump from the system and seal off the inlet and exhaust ports. Bring the pump to the maintenance area immediately.
- Drain pump (*see Operating instructions*).

DANGER

Do not store a pump in this condition for any length of time: once the neutral gas has dissipated, the inside of the oil case will be in contact with the ambient air laden with water vapor; this may react with the pumped gases to form acids that may corrode the pump even at room temperature.

The first phase of disassembly is to disassemble the motor, the second is to disassemble the pumping module.

Follow the chronological order of disassembling instructions. See the drawings and their part lists in pages N – 1 to N – 23.

Disassembling the motor block

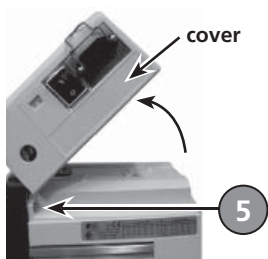

- 3 Remove the motor cover.
- 5 Remove the motor attachment screws (5) (*see page N – 18*).

If the motor is damaged, replace it (*see page N – 19*).

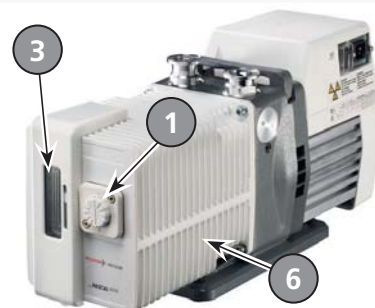

Disassembling the fan coupling

(*see page N – 2*)

- 4 Remove the fan (33) fastening screw (28) and the support washer (26). Remove the key.

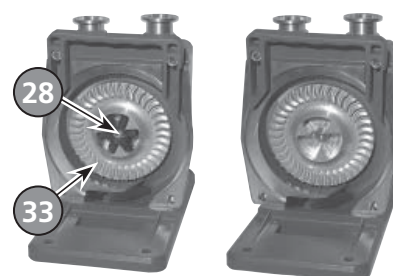

Replacing the front seal

See *page 7*.

Disassembling the gas ballast

except model pump C2 (*see page N – 2*)

- 25 Remove the gas ballast cover (58) (2 screws), the adjustment button (55), the spring (54) and the sleeve (53).

Remove the tank feed-through (49) (2 screws) and its seal (48).

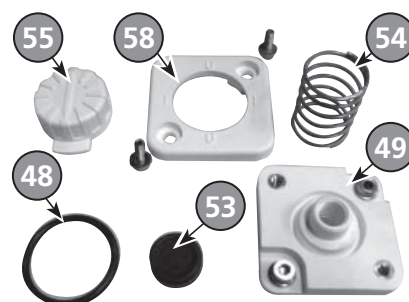

Disassembling the oil sight glass (see page N – 2)

3 Remove the sight glass cover (3).

Remove the plate (1), the ring (4a), the sight glass (4) and the O-ring (5).

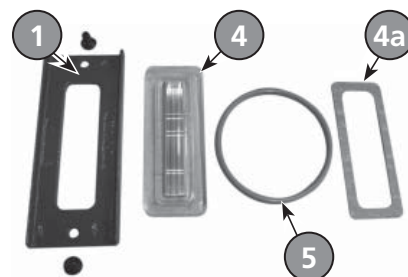

Removing the oil case (see page N – 2)

5 Remove the oil case (6) and its O-ring (11) after removing the 4 fastening screws (9).

Disassembling the bubbler (C2 pump) (see page N – 20)

10 Disconnect the nitrogen inlet. Remove the nitrogen inlet and disconnect the coupling (2) without unscrewing the connector (6).

Disconnect the nut (16) which secures the tube on the functional block and pull the bubble (8) to release it from the frame.

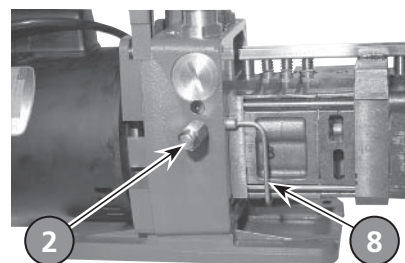

Disassembling the exhaust valve cover (see page N – 6)

5 Remove the screws (4) (13) (15) and the cover(s) (6) (17), the exhaust valves (2) (11) and their springs (3) (12).

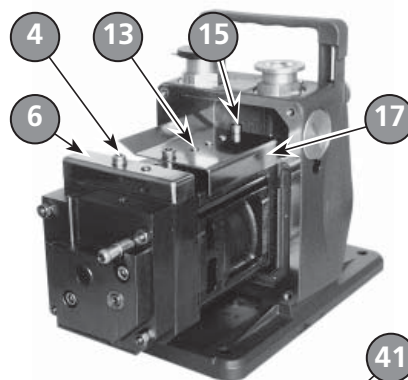

Disassembling the sniffer pipe (SDI model) (see page N – 10)

5 Remove the screw (41) and its washer.

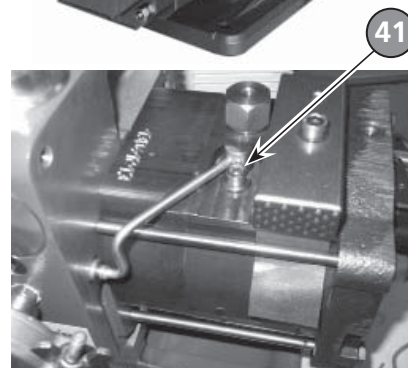

Insert a flat screwdriver near to the stator connector, and use it as lever arm to remove the sniffer pipe (38) from the stator. Then, pull on the other end of the pipe to remove it from the housing.

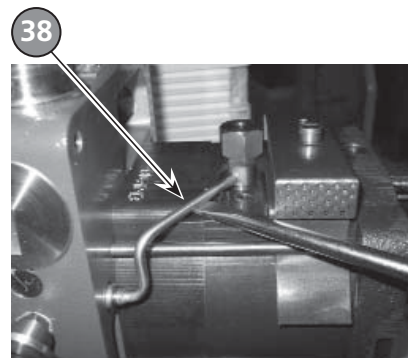

Disassembling the pump (cont'd)

Disassembling the SD/SDI pump oil system

(except 1015 SD)
(see page N – 16)

The oil system is set in the factory, it must be reset in the event of disassembly (see reassembly). However, the rear flange (4) can be disassembled without modifying the setting.

Remove the spinner-cam (6) by removing the circlip (7).

Do not disassemble the nozzle (8) to clean it. During the reassembly, check that it is not blocked by sending a jet of compressed air through it.

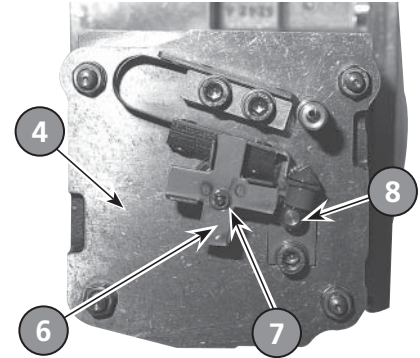

Disassembling the pump oil system I, C1, C2 pumps and 1015 SD

(see page N – 14)

5 Remove the cover from the oil pump (1). Release the cylinder (13) equipped with the washer (14), piston (11) and spring (12).

Release the stop valve (10) from its housing.

12 In the rear flange, unscrew the seat of the stop valve (9) and remove the O-ring (8).

Then remove the vane (4), the oil pump rotor (3) and the Oldham coupling (5).

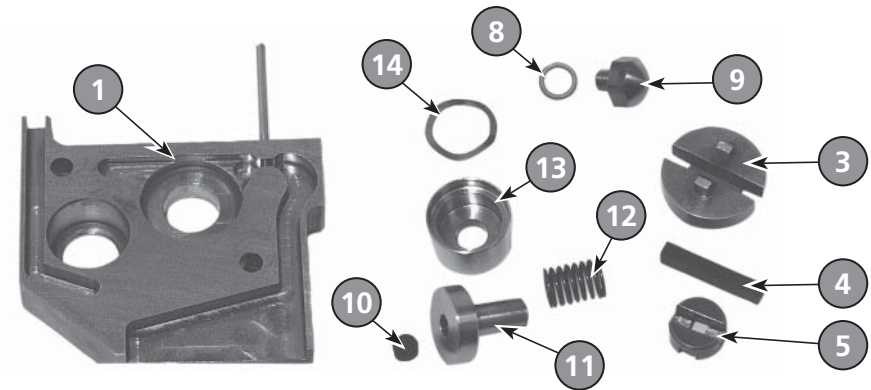
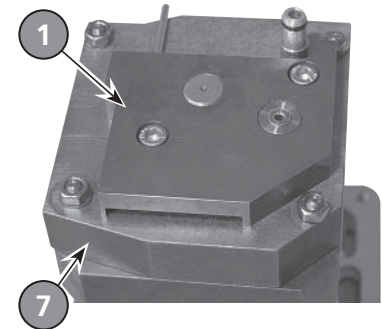

Disassembling the rear flange

(see pages N – 14 et N – 16)

10 Remove the 4 nuts. Release the flange (7) in the axis.

Disassembling the pumping module with flanged stator

(see N – 10)

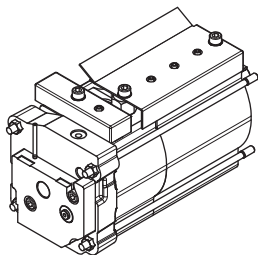

2 stages models: steps 1 to 4

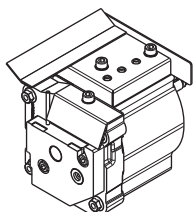

1 stage models: steps 3 to 4

- 1 Insert two screwdrivers in the notches and release the set HP stator (34) and HP rotor (31) in the axis.

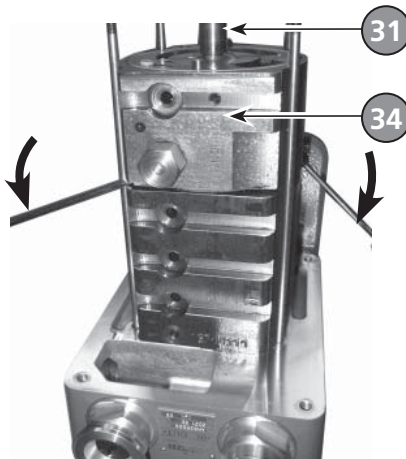

- 2 Release the HP rotor (31) from the HP stator (34) and the vanes.

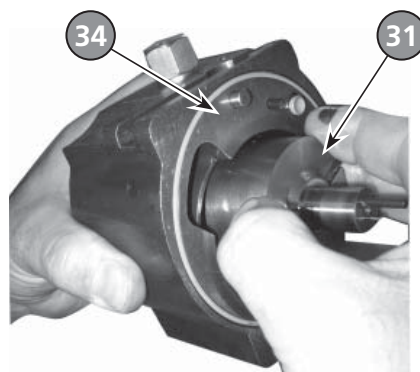

- 3 Insert two screwdrivers in the notches and release the set BP stator (26) and BP rotor (23) in the axis.

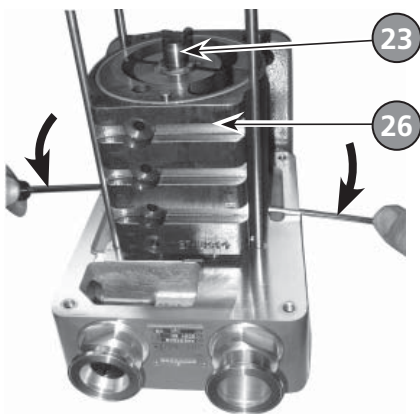

- 4 Release the BP rotor (23) from the BP stator (26) and the vanes.

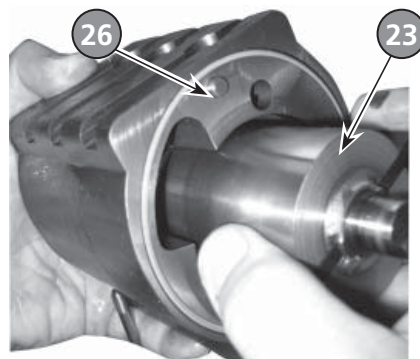

Disassembling the pump (cont'd)

Disassembling the pumping module with no flanged stator (see N - 6)

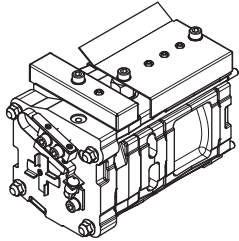

1 Remove the HP stator (34) by sliding it along the HP rotor (31). Remove the HP rotor and the vanes.

2 Insert two screwdrivers in the notches and release the central plate (29) in the axis.

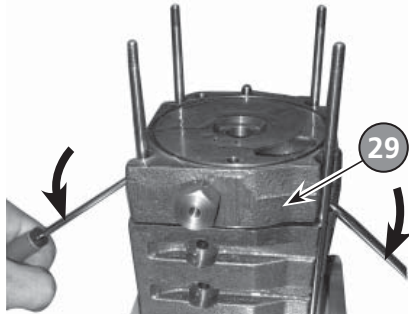
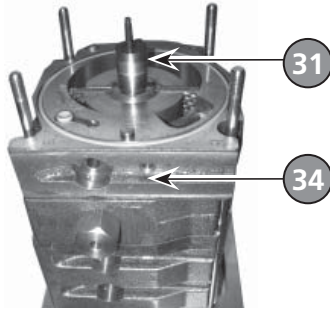

3 Insert two screwdrivers in the notches and release the BP stator (26) by sliding it along the BP rotor (23). Remove the BP rotor and the vanes.

4 Release the front plate (19).

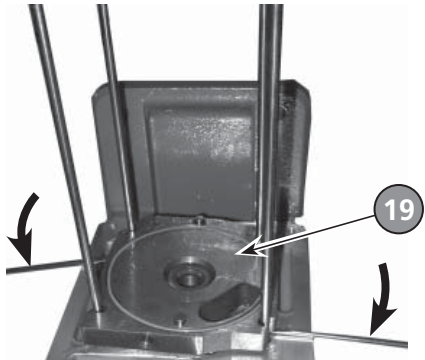
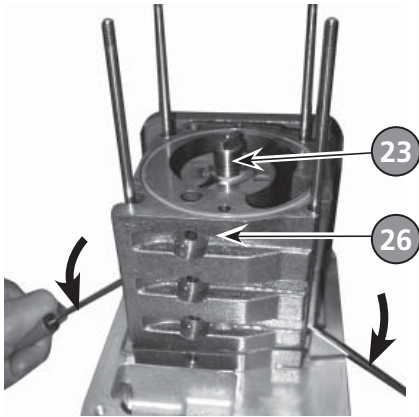

Note : If one of the pumping module part with no flanged stator is damaged and must be replaced, it is necessary to replace it by new parts from a flanged stator configuration (refer to N - 21, N - 23 for spare part list).

Cleaning components

Cleaning metal components

Solvents are required to clean components.

Standard precautions should be taken in compliance with the manufacturer's instructions.

After use in mineral or synthetic oil, clean the metal components with a mineral products based solvent such as **AXAREL**⁽¹⁾, **CARECLEAN**⁽²⁾, **PREMACLEAN**⁽³⁾, **NAPHTESOL**⁽⁴⁾. Proceed as follows:

- Clean when cold or hot (max. 45 °C) by dipping or using a cloth
- Vacuum dry in a ventilated oven
- **The component must be cleaned a second time with alcohol.**

After use in (perfluorinate) synthetic oil, clean the metal components in a solvent such as **GALDEN S 90**^{TM(5)} and proceed as follows:

- Clean when cold by dipping or using a cloth
- Dry the components in the air or with compressed air

After use in (non-perfluorinate) synthetic or mineral oil, clean the metal components with a solvent such as alcohol and proceed as follows:

- Clean when cold by dipping or using a cloth
- Dry the components in the air
- Industrial washing solutions can also be used. The cleaning operation should be followed by vacuum drying.

Cleaning the oil level sight glass

I, SD, SDI, C2 series pumps

When cleaning this plastic sight glass, avoid contact with alcohol or alcohol-based washing solutions. Clean the component with a solvent, but do not steep it, and rinse it immediately.

C1 series pumps

The sight glass of these pumps is made of glass: it can be cleaned with common used solvents.

(1) DUPONT DE NEMOURS registered trademark

(2) CASTROL registered trademark

(3) DOW registered trademark

(4) Nippon Oil Corporation registered trademark

(5) MONTEDISON registered trademark

Replacement of shaft seals

- Specific tools**
- Specific extraction tool.
 - Specific assembly mandrel.
 - A support plate (or washer).

- Recommended tools**
- A flat screwdriver .
 - A hammer.

Extracting a shaft seal from its housing

- Flange (**picture 1**): the seal is extracted using a screwdriver, resting on the plate (or washer) so as not to damage the seal housing, or
- Flanged stator (**picture 2**): the seal is extracted with the specific extraction tool.

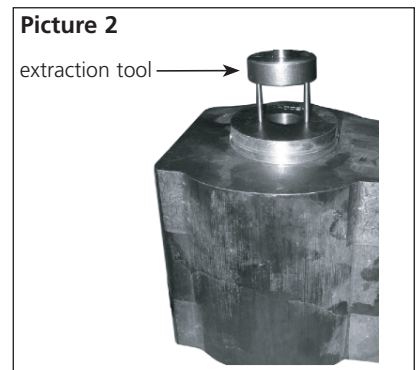
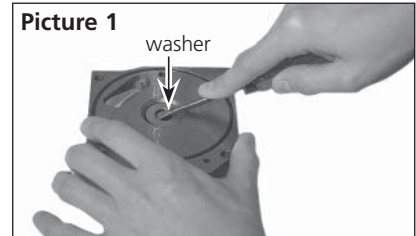

Assembling the shaft seal

The seal housing and the seal lip are lubricated with the lubricant used in the pump. The flange is resting on a flat surface.

According to the direction of assembly, the seal is fitted on the assembly mandrel.

Using a press or a hammer, the seal is inserted in its housing.

Check the position of the seal: it must lean against its bearing.

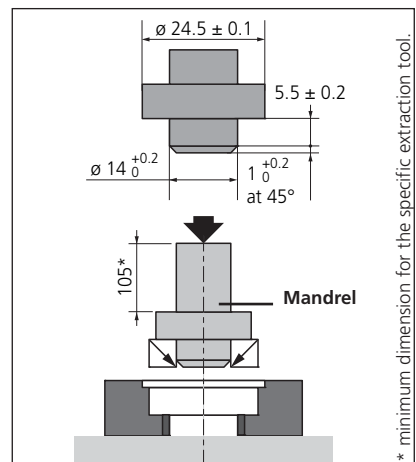

Direction of assembly of shaft seals

They are fitted using the assembly mandrel according to the direction of assembly below:

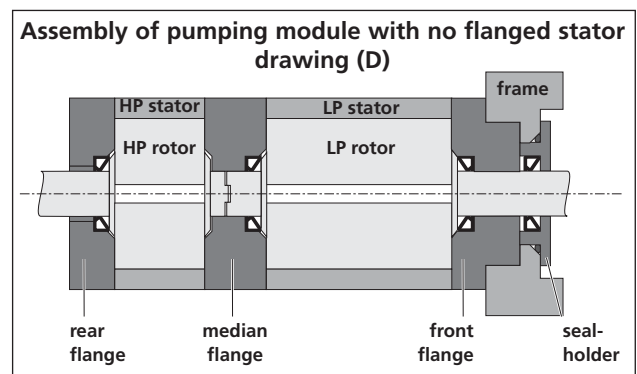
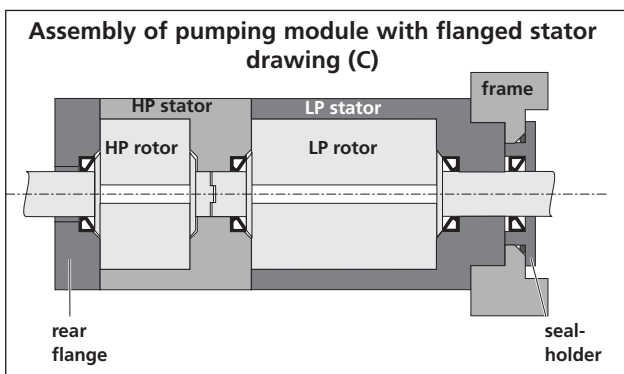

Reassembling the pump

Component preparation

- All surfaces in contact are coated with oil (rotors, vanes...).
- Check that the lubrication holes are not blocked.
- Observe the **nominal clamping torques for the reassembly of the functional block** (see chapter "Nomenclature").
- Rest the frame (42) on a flat surface in order to raise the pump.

Reassembling the pumping module with flanged stator (see page N – 10)

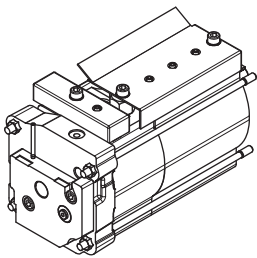

2 stages models: steps 1 to à 6

- 1** Place the BP stator (26) on the frame (42).
If there is no centering pin, align the top of the stator with the exhaust notch in the housing.

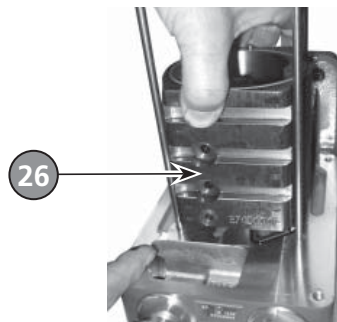

- 2** For not damage the shaft seal, use protective sleeve on the rotor axis (or wrap end of shaft with adhesive tape) and oil it.

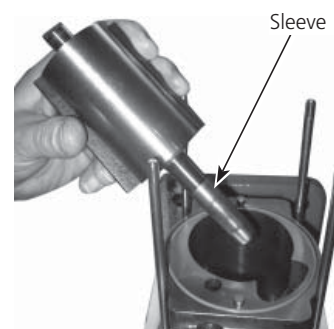

- 3** Slide the BP rotor (23) equipped with its vanes and springs (rounded edges facing outwards) in the BP stator (26). Remove the protective sleeve.

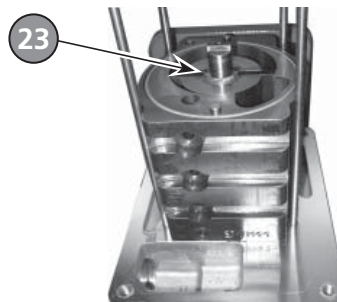

- 4** Place the HP stator (34) on the BP stator (26).

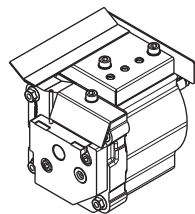
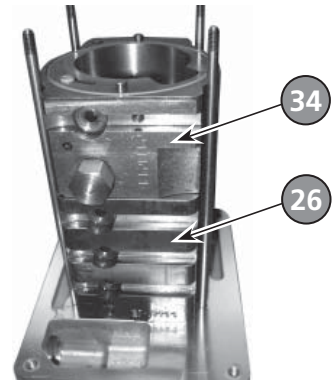

1 stage models: steps 1, 2, 3 and 6

- 5** Slide the HP rotor (31) equipped with its vanes and springs (rounded edges facing outwards) in the HP stator (34).

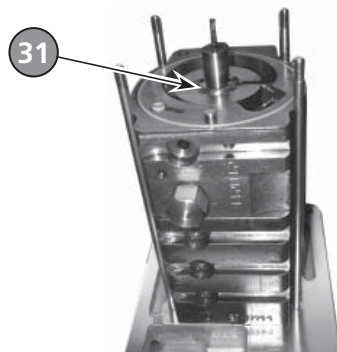

- 6** Place the rear flange (7) on the HP stator (34).

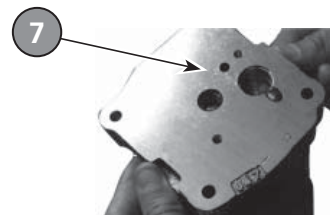

Reassembling the pump (cont'd)

Reassembling the pumping module with no flanged stator (see page N – 6)

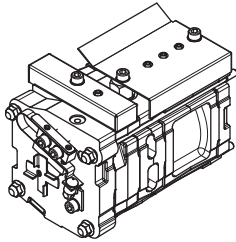

- 1** Fit the front plate (19) on the frame (42).

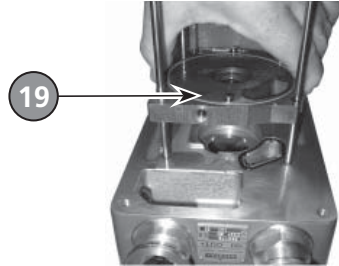

- 2** For not damage the shaft seal, use protective sleeve on the rotor axis (or wrap end of shaft with adhesive tape) and oil it.

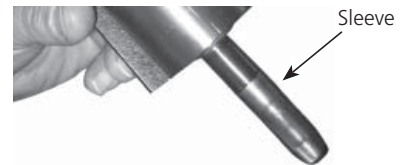

- 3** Place the BP Rotor (23) equipped with its vanes and springs (rounded edges facing outwards) on the front plate (19). Remove the protective sleeve.

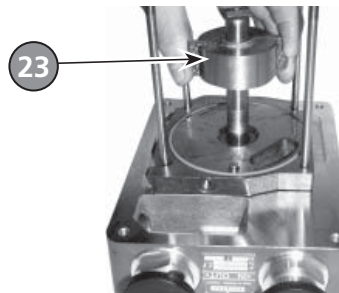

- 4** Slide the BP stator (26) on the BP rotor (23).

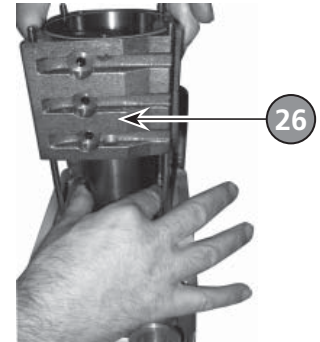

- 5** Place the central plate (29) on the BP stator (26).

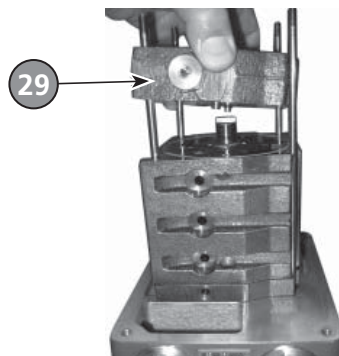

- 6** Place the HP rotor (31) equipped with its vanes and springs (rounded edges facing outwards) on the central plate (29).

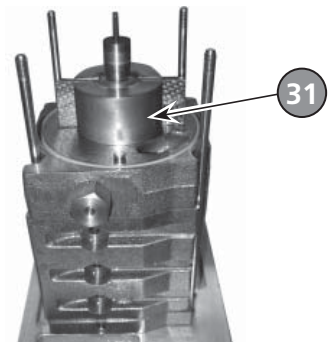

- 7** Slide the HP stator (34) on the HP rotor (31).

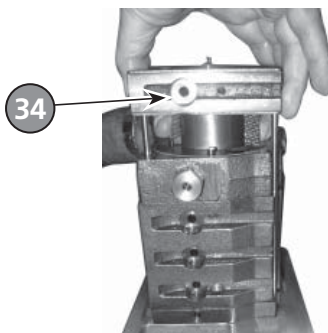

- 8** Place the rear plate (7) on the HP stator (31).

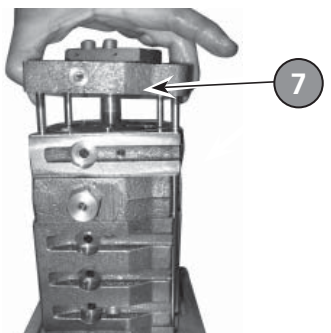

Reassembling the oil system

Spinner-cam, SD and SDI pumps
(except 1015 SD)
(see page N – 16)

Spinner-cam settings

Check that the nozzle is not blocked by sending a jet of compressed air through it.

Place the spinner-cam system on the rear plate (4) and fix it with the clips (7).

Offset the spinner-cam (a) by pressing on the blades.

Turn the shaft up to the maximum displacement of the lever (b).

The distance between the seat (c) and the stop valve (d) must be 0.9 to 1.2 mm (0.035 to 0.047 inch): it is set by adjusting the orientation of the lever.

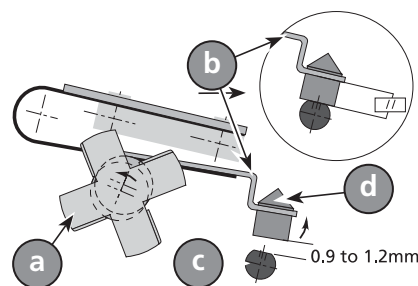

The stop valve face must be perpendicular to the axis of the oil inlet hole; when free, the stop valve should rest on its seat: check the parallelism of the lever in relation to the bearing face of the stop valve seat. Orient the seat to obtain the correct setting.

Oil pump, I, C1 and C2 pumps
(and 1015 SD)
(see page N – 14)

Oil pump settings

In the rear plate (7), place the Oldham coupling (5), the vane (4) and the rotor (3).

Screw the seat (9) equipped with its O-ring (8). Place the piston (11) with its antiskid-back device (10), the spring (12), the cylinder (13) and the washer (14).

Position the rotor of the oil pump so that the slot is horizontal (or parallel with the pump base). To turn it, use the fan.

Reassembling the exhaust valve cover

(see page N – 6)

Pump in a horizontal position, pour a small quantity of oil beforehand around the exhaust valve holes.

Place the valves (2) or (11) equipped with the springs (3) or (12)

Place the valve covers (6) or (17) and fix them with screws and washers.

Reassembling the bubble device

C2 pump (see page N – 20)

Insert the bubbler (8) equipped with its o-ring in the frame.

Position the tube fastener (9) on the pin and tighten the nut on the rear plate (7).

Insert the ball (4), the spring (5) in the coupling (2) and tighten it on the connector (6).

Reassembling the oil casing

(see page N – 6)

Fit the oil casing (6) equipped with its o-ring (11) on the frame (42).

Tighten it with screw (9) and washers (10) (after making sure that the seal is positioned in its seal groove).

Reassembling the oil level sight glass

(see page N – 2)

Place the o-ring (5) in its groove and fit the sight glass (4), the flat ring (4a) (according to the model), the oil sight glass cover (3) and tighten with screws (2). Comply with the recommended tightening torque.

CAUTION

C1 series pump: The sight glass is made of glass: gradually tighten the two attachment screws in alternation to avoid placing the sight glass under stress.

Reassembling the gas ballast

(see page N – 2)

Position the oil case feed-through (49) equipped with its o-ring (48) in its housing by centering it on the gas ballast tube (46). Assemble using the screws (52).

Equip the adjustment knob (55) with the sleeve (53) and the spring (54). Position the assembly in the cover (58) and secure on the oil case feed-through (49) with screws (57).

Reassembling the pump (cont'd)

Reassembling the seal-holder (see page N – 2)

(See page 7).

Reassembling the fan and the motor side components (see page N – 2)

Fit the shaft key (22) (N – 10) on HP rotor.
Fit the coupling fan (33) and secure it with the screw (28) and washer (26).
Fit the drive key on the motor shaft. Install the motor coupling (3) (N – 18) down to the stop on the motor shaft and secure it with the screw (2) (N – 18).
Install the plastic coupling (4) (N – 18) on the motor coupling (3) (N – 18).
Fit the motor on the frame and secure with the 4 mounting bolts (5) (N – 18).

Fill with oil

After reassembling, fill the pump with oil before start-up the pump (see *Operating instructions*).

Reassembling of the pumping pipe (model SDI)

Position one the end of the pipe (38) into the housing hole designed for this purpose and the other end on the stator (34).
Do not forget to install o-rings (39) and (40) after having checked their status (no cuts).

Service

Pfeiffer Vacuum offers first-class customer service!

- On-Site maintenance for many products
- Overhaul / repair in the nearby Service Location
- Fast replacement with refurbished exchange products in mint condition
- Advice on the most cost-efficient and quickest solution

Detailed information, addresses and forms at: www.pfeiffer-vacuum.com (Service).

Overhaul and repair in the Pfeiffer Vacuum Service Center

The following general recommendations will ensure a fast, smooth servicing process:
→ Fill out the «Service Request/Product return» form and send it to your local Pfeiffer Vacuum Service contact.

- Include the confirmation on the service request from Pfeiffer Vacuum with your shipment.
- Fill out the declaration of contamination and include it in the shipment (mandatory!). The Declaration of contamination is valid for any product/device including a part exposed to vacuum.
- Dismantle all accessories and keep them.
- Close all the ports flange openings by using the original protective covers or metallic airtight blank flanges for contaminated devices.

If possible, send pump or unit in its original packaging.

Sending of contaminated pumps or devices

No devices will be accepted if they are contaminated with micro-biological, explosive or radioactive substances. "Hazardous substances" are substances and compounds in accordance with the hazardous goods regulations (current version).

- Neutralize the pump by flushing it with nitrogen or dry air.
- Close all openings airtight.
- Seal the pump or device in suitable protective film.
- Return the pump/device only in a suitable and sturdy transport container and send it in while following applicable transport conditions.

Pump or device returned without declaration of contamination form fully completed and/or non-secured in a suitable packaging, will be decontaminated and/or returned at the shipper's expense.

Exchange or repaired devices

The factory operating parameters are always preset with exchange or repaired devices. If you use specific parameters for your application, you have to set these again.

Service orders

All service orders are carried out exclusively according to our general terms and conditions for the repair and maintenance, available in our website.

Composants de maintenance / Maintenance components / Ersatzteilliste

Plan de montage cuve et bâti	Oil casing and central housing assembly drawing	Gesamtplan Ölbehälter und Pumpenträger.....	2 / 4
Nomenclature cuve et bâti.....	Oil casing and central housing part list	Nomenklatur Ölbehälter und Pumpenträger.....	3 / 5
Plan du bloc fonctionnel (avec stator non flasqué) (D).....	Pumping module drawing (with no flanged stator) (D)	Gesamtplan: Funktionsblock mit Stator und Flanschen (D).....	6 / 8
Nomenclature du bloc fonctionnel..... (avec stator non flasqué) (D)	Pumping module part list (with no flanged stator) (D)	Nomenklatur: Funktionsblock mit Stator und Flanschen (D).....	7 / 9
Plan du bloc fonctionnel (avec stator flasqué) (C).....	Pumping module drawing (with flanged stator) (C)	Gesamtplan: Funktionsblock mit Stator-Monoblock (C)	10 / 12
Nomenclature du bloc fonctionnel..... (avec stator flasqué) (C)	Pumping module part list (with flanged stator) (C).....	Nomenklatur: Funktionsblock mit Stator-Monoblock (C).....	11 / 13
Plan du système de lubrification pompe à huile (A).....	Oil pump system drawing (A)	Gesamtplan (A) Ölpumpsystem	14
Nomenclature du système de lubrification	Oil pump system part list (A).....	Nomenklatur (A) Ölpumpsystem.....	15
pompe à huile (A)			
Plan du système de lubrification levier moulinet (B).....	Oil system drawing (B).....	Gesamtplan (B) Flügelrad-Ölsystem	16
Nomenclature du système de lubrification	Oil system part list (B).....	Nomenklatur (B) Flügelrad-Ölsystem.....	17
levier moulinet (B)			
Plan ensemble motorisation (M).....	Motor assembly drawing (M).....	Gesamtplan (M) Motor.....	18
Nomenclature ensemble motorisation (M).....	Motor assembly part list (M)	Nomenklatur (M) Motor	19
Plan du système bulleur	Bubbler system drawing	Gesamtplan Bubbler system	20
Nomenclature du système bulleur.....	Bubbler system part list.....	Nomenklatur Bubbler system.....	20
Remplacement des pièces du bloc fonctionnel non flasqué.....	Pumping module (with no flanged stator) spare parts.....	Pumpenblock (mit Stator und Flanschen) Unterhaltung Teile.....	21

Plan de montage cuve et bâti
Oil casing and central housing assembly drawing
Ölbehälter und Pumpenträger Gesamtplan

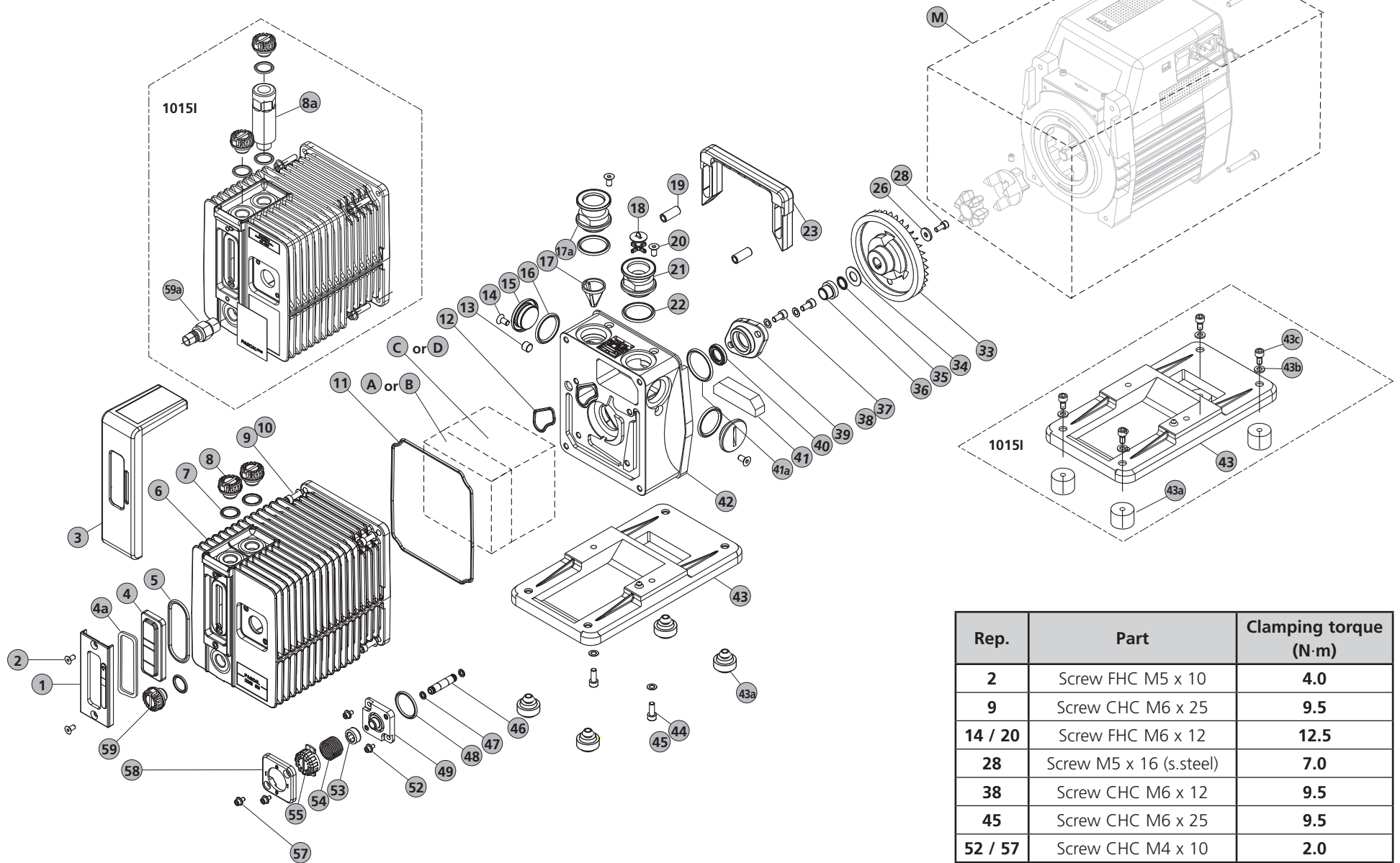

Rep.	Part	Clamping torque (N·m)
2	Screw FHC M5 x 10	4.0
9	Screw CHC M6 x 25	9.5
14 / 20	Screw FHC M6 x 12	12.5
28	Screw M5 x 16 (s.steel)	7.0
38	Screw CHC M6 x 12	9.5
45	Screw CHC M6 x 25	9.5
52 / 57	Screw CHC M4 x 10	2.0

Plan de montage cuve et bâti
Oil casing and central housing assembly drawing
Ölbehälter und Pumpenträger Gesamtplan

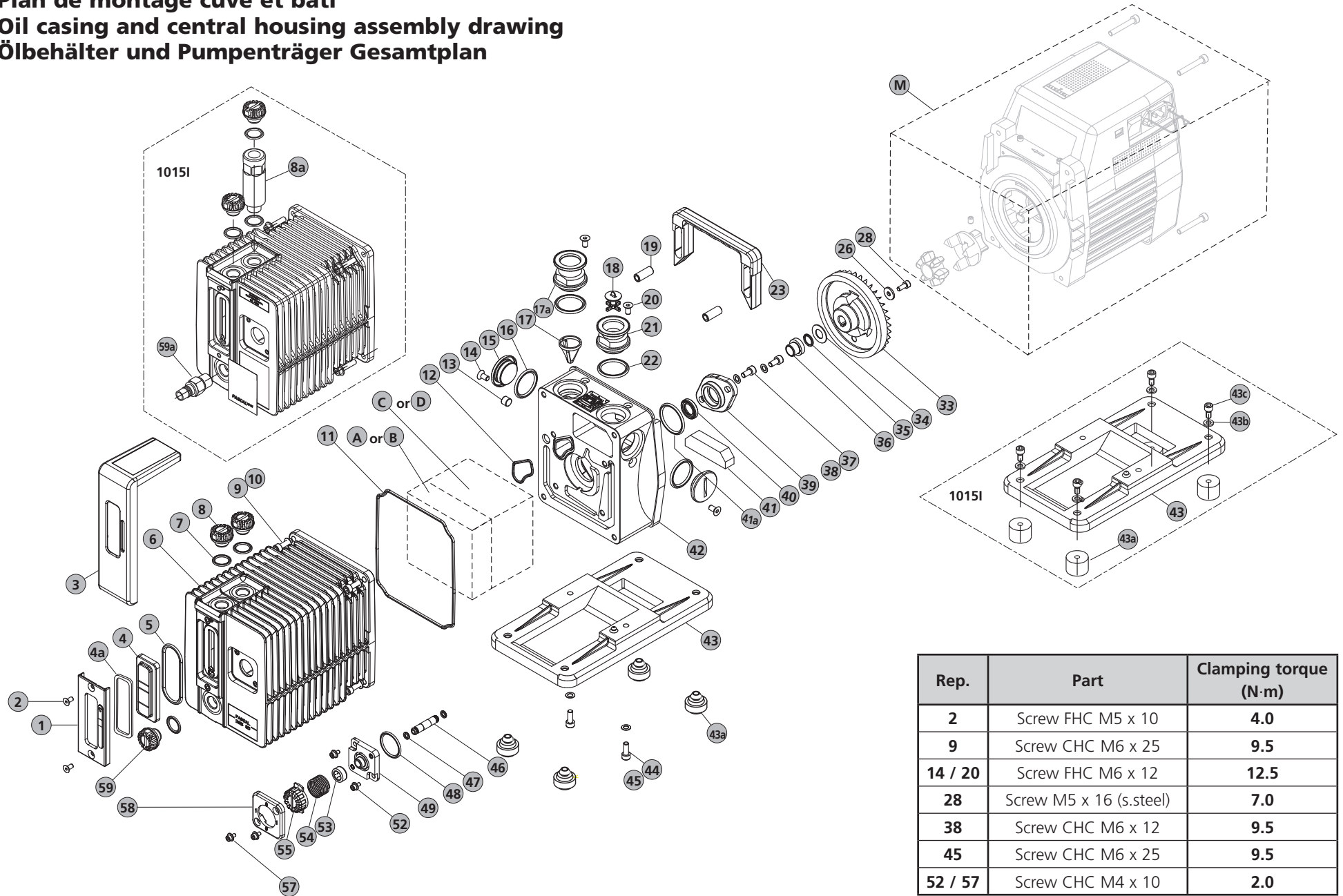

Rep.	Part	Clamping torque (N·m)
2	Screw FHC M5 x 10	4.0
9	Screw CHC M6 x 25	9.5
14 / 20	Screw FHC M6 x 12	12.5
28	Screw M5 x 16 (s.steel)	7.0
38	Screw CHC M6 x 12	9.5
45	Screw CHC M6 x 25	9.5
52 / 57	Screw CHC M4 x 10	2.0

Nomenclature cuve et bâti / Oil casing and central housing part list / Ölbehälter und Pumpenträger Nomenklatur

REP	DÉSIGNATION	SPECIFICATION	BENENNUNG	Types/model																	REF. P/N Bestell. Nr		
				2005 I	2010 I	2015 I	2021 I	1015 I	2005 SD	2005 SDI	2010 SD	2015 SD	2021 SD	1005 SD	1015 SD	2010 C2	2015 C2	2021 C2	2005 C1	2010 C1		2015 C1	2021 C1
34	Rondelle d'appui	Washer	Unterlegscheibe	1	1	1	1	1	1	1	1	1	1	1	1	1	1	1	1	1	1	1	065847
35	Joint torique c 2,7 - d 12,1 Bague R10	O-ring c 2.7 - d 12.1 - Ring R10	Dichtung c 2,7 - d 12,1 - Ring R10	1	1	1	1	1	1	1	1	1	1	1	1	1	1	1	1	1	1	1	●
36	Bague épaulée	Shouldered ring	Abnutzungsring	1	1	1	1	1	1	1	1	1	1	1	1	1	1	1	1	1	1	1	065823
37	Idem 10	Idem 10	Ebenso 10	2/8	2/8	2/8	2/8	2/8	2/8	2/8	2/8	2/8	2/8	2/8	2/8	2/8	2/8	2/8	2/8	2/8	2/8	2/8	⊕
38	Vis CHC M6 x 12	Screw CHC M6 x 12	Schraube CHC M6 x 12	2	2	2	2	2	2	2	2	2	2	2	2	2	2	2	2	2	2	2	⊕
39	Porte joint	Seal holder	Lippendichtung-sockel	1	1	1	1	1	1	1	1	1	1	1	1	1	1	1	1	1	1	1	A333660
40	Joint à lèvres 15 x 25,5 x 4,6 FMP81	Shaft seal 15 x 25.5 x 4.6 FMP81	Lippendichtung 15 x 25,5 x 4,6 FMP81	1	1	1	1	1	1	1	1	1	1	1	1	1	1	1	1	1	1	1	● *
41	Feutre	Felt	Filz	1	1	1	1	1	1	1	1	1	1	1	1	1	1	1	1	1	1	1	● *
41a	Joint torique c 3,6-d 34,1	O-ring c 3.6-d 34.1	Dichtung c 3,6 - d 34,1	1	1	1	1	1	1	1	1	1	1	1	1	1	1	1	1	1	1	1	● *
42	Bâti équipé*	Equipped central housing*	Pumpenträger einrichtet*	1	1	1	1	1															1033845
42	Bâti équipé*	Equipped central housing*	Pumpenträger einrichtet*						1														1033855
42	Bâti équipé*	Equipped central housing*	Pumpenträger einrichtet*							1													1058345
42	Bâti équipé*	Equipped central housing*	Pumpenträger einrichtet*													1	1	1	1	1	1	1	1058325
43	Socle	Base	Fuss	1	1	1	1		1	1	1	1	1	1	1	1	1	1	1	1	1	1	108712
43	Socle	Base	Fuss					1															1071345
43a	Amortisseur	Shock mount	Schwingungsdämpfer	4/4	4/4	4/4	4/4		4/4	4/4	4/4	4/4	4/4	4/4	4/4	4/4	4/4	4/4	4/4	4/4	4/4	4/4	065790
43a	Amortisseur	Shock mount	Schwingungsdämpfer					4/4															082691
43b	Rondelle	Washer	Unterlegscheibe					4/4															⊕
43c	Vis CHC M6 x 12	Screw CHC M6 x 12	Schraube CHC M6 x 12					4/4															⊕
44	Idem 10	Idem 10	Ebenso 10	2/8	2/8	2/8	2/8		2/8	2/8	2/8	2/8	2/8	2/8	2/8	2/8	2/8	2/8	2/8	2/8	2/8	2/8	⊕
45	Idem 9	Idem 9	Ebenso 9	2/6	2/6	2/6	2/6		2/6	2/6	2/6	2/6	2/6	2/6	2/6	2/6	2/6	2/6	2/6	2/6	2/6	2/6	⊕
46	Tube lest d'air	Gas ballast tube	Gasballastrohr	1	1	1	1		1	1	1	1	1			1	1	1	1	1	1	1	104631
46	Tube lest d'air	Gas ballast tube	Gasballastrohr											1									065842
46	Tube lest d'air	Gas ballast tube	Gasballastrohr					1						1									065839
47	Joint torique c 1,9 - d 5,7 Bague R5	O-ring c 1.9 - d 5.7 - Ring R5	Dichtung c 1,9 - d 5,7 - Ring R5	2	2	2	2		2	2	2	2	2	2	2	2	2	2	2	2	2	2	●
48	Joint torique c 3 - d 28	O-ring c 3 - d 28	Dichtung c 3 - d 28	1	1	1	1		1	1	1	1	1	1	1	1	1	1	1	1	1	1	●
49	Traversée de cuve	Oil case feedthrough	Ölbehälterdurchfuhrung	1	1	1	1																102853
49	Traversée de cuve	Oil case feedthrough	Ölbehälterdurchfuhrung					1	1	1	1	1	1	1									102852
49	Traversée de cuve	Oil case feedthrough	Ölbehälterdurchfuhrung												1	1	1	1	1	1	1	1	100952
52	Vis M4 x 10	Screw M4 x 10	Schraube M4 x 10	2/4	2/4	2/4	2/4	2/4	2/4	2/4	2/4	2/4	2/4	2/4	2/4	2/4	2/4	2/4	2/4	2/4	2/4	2/4	⊕
53	Manchon lest d'air	Gas ballast sleeve	Gasballastmuffe	1	1	1	1	1	1	1	1	1	1	1	1	1	1	1	1	1	1	1	●
54	Ressort lest d'air	Gas ballast spring	Gasballastfeder	1	1	1	1		1	1	1	1	1	1	1					1	1	1	■
55	Bouchon de manoeuvre	Gas ballast knob	Gasballastknopf	1	1	1	1		1											1	1	1	102846
55	Bouchon de manoeuvre	Gas ballast knob	Gasballastknopf							1	1	1	1	1	1								102845
57	Idem 52	Idem 52	Ebenso 52	2/4	2/4	2/4	2/4	2/4	2/4	2/4	2/4	2/4	2/4	2/4	2/4	2/4	2/4	2/4	2/4	2/4	2/4	2/4	⊕
58	Couvercle lest d'air	Gas ballast cover	Gasballastdeckel	1	1	1	1																107789
58	Couvercle lest d'air	Gas ballast cover	Gasballastdeckel						1	1	1	1	1	1									107790
58	Couvercle lest d'air	Gas ballast cover	Gasballastdeckel													1	1	1					107792
58	Couvercle lest d'air	Gas ballast cover	Gasballastdeckel					1															107793
59	Idem 8	Idem 8	Ebenso 8	1/3	1/3	1/3	1/3		1/3	1/3	1/3	1/3	1/3	1/3	1/3					1/3	1/3	1/3	■
59	Idem 8	Idem 8	Ebenso 8													1/3	1/3	1/3	1/3	1/3	1/3	1/3	052752
59a	Raccord rapide	Quick connect	Schnellkupplung					1															107523

● Lot de joints / Seal kit / Dichtungssatz ■ Kit de révision / Overhaul kit / Revision kit ⊕ Lot visserie / Screw kit / Schraubensatz ○ Lot palettes / Vane kit / Schieberersatz * Kit joint avant / Front seal kit / Vorderer Dichtungssatz

* Pour les pompes utilisées dans les détecteurs (sauf pompe 1005I), utiliser le bâti A0067315

* For pumps used in detectors (except 1005I pump), use A0067315 housing

* Für Pumpen, die in den Lecksuchgeräten verwendet werden (außer Pumpe 1005I), den Rahmen A0067315 verwenden

Plan du bloc fonctionnel (avec stator non flasqué) (D)
Pumping module drawing (with no flanged stator) (D)
Gesamtplan: Funktionsblock mit Stator und Flanschen (D)

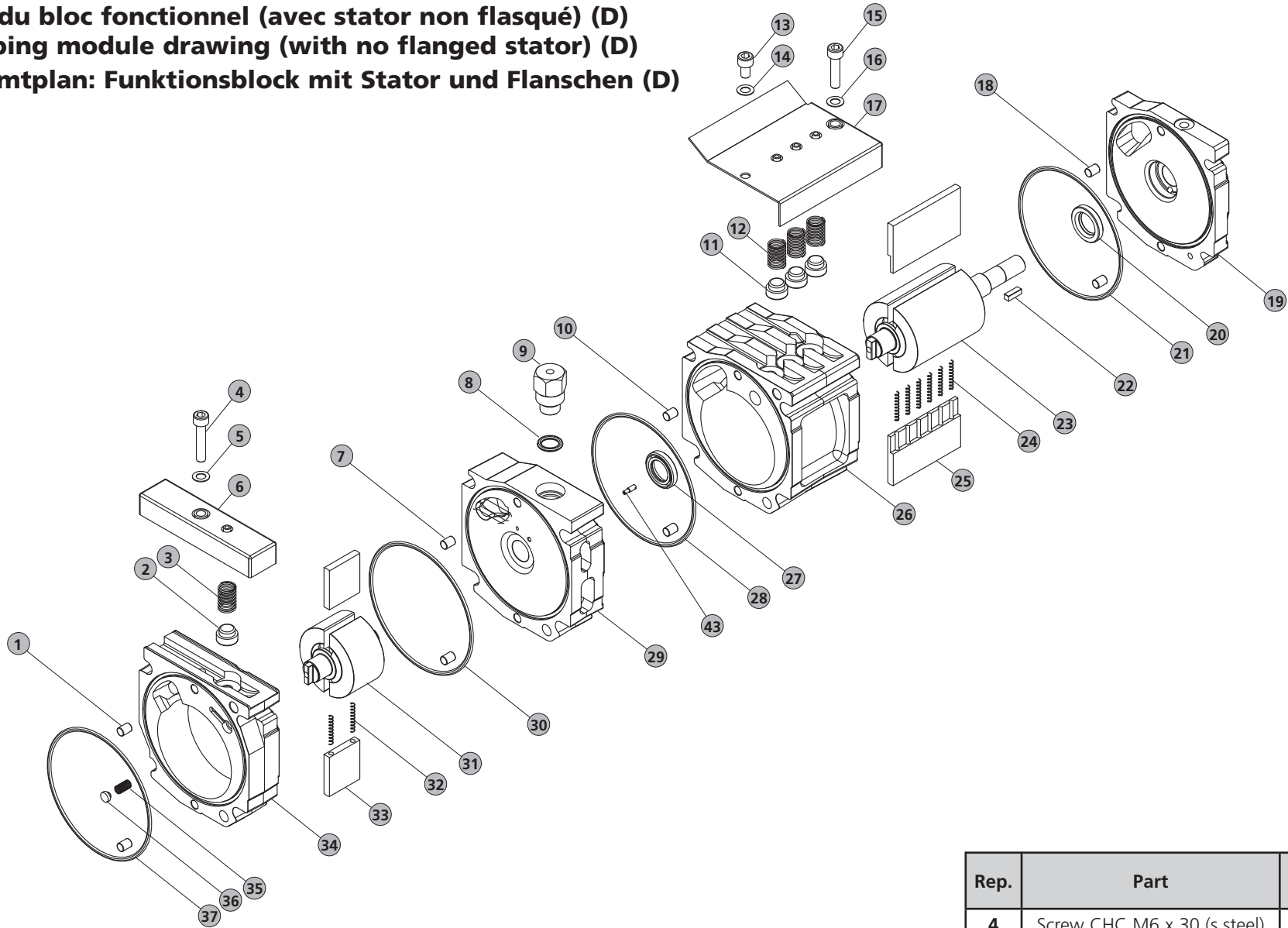

Rep.	Part	Clamping torque (N·m)
4	Screw CHC M6 x 30 (s.steel)	9.0
13	Screw CHC M6 x 10 (s.steel)	9.0
15	Screw CHC M6 x 25 (s.steel)	9.0

Plan du bloc fonctionnel (avec stator non flasqué) (D)
Pumping module drawing (with no flanged stator) (D)
Gesamtplan: Funktionsblock mit Stator und Flanschen (D)

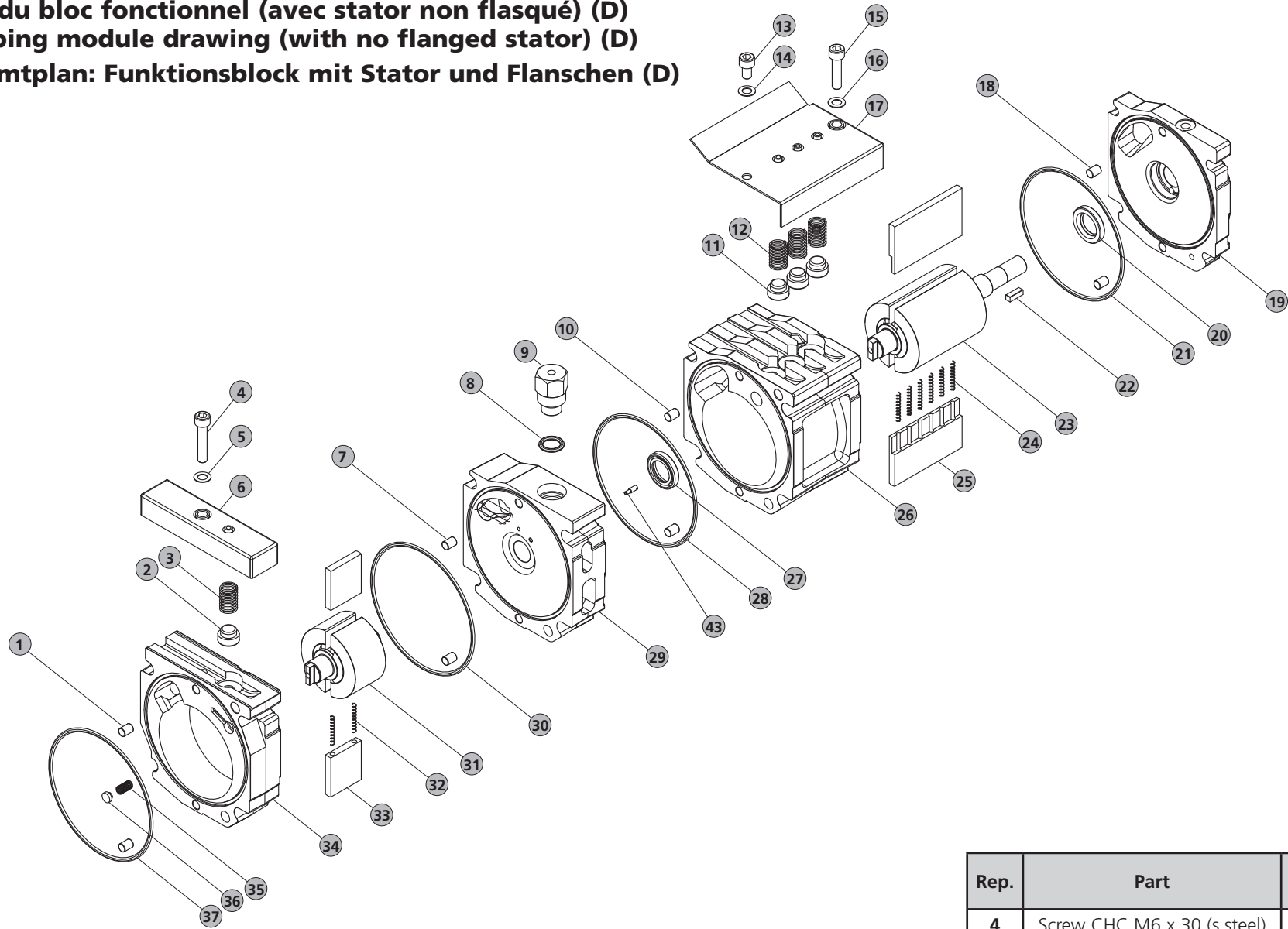

Rep.	Part	Clamping torque (N·m)
4	Screw CHC M6 x 30 (s.steel)	9.0
13	Screw CHC M6 x 10 (s.steel)	9.0
15	Screw CHC M6 x 25 (s.steel)	9.0

Nomenclature du bloc fonctionnel (avec stator non flasqué) (D)

Pumping module list (with no flanged stator) (D)

Nomenklatur: Funktionsblock mit Stator und Flanschen (D)

REP	DÉSIGNATION	SPECIFICATION	BENENNUNG	Types/model																REF. P/N Bestell. Nr					
				2005 I	2010 I	2015 I	2021 I	2005 SD	2005 SDI	2010 SD	2015 SD	2021 SD	1005 SD	1015 SD	2010 C2	2015 C2	2021 C2	2005 C1	2010 C1		2015 C1	2021 C1			
25	Palette BP	LP vane	Niederdruckschieber	2	2	2	2	2	2	2	2	2	2	2	2	2	2	2	2	2	2	2	2	2	●○
26	Stator BP	LP stator	Niederdruckstator	1				1	1									1						103507S	
26	Stator BP	LP stator	Niederdruckstator		1					1											1			103512S	
26	Stator BP	LP stator	Niederdruckstator			1					1							1					1	103510S	
26	Stator BP	LP stator	Niederdruckstator				1					1											1	103393S	
26	Stator BP	LP stator	Niederdruckstator										1											103409S	
26	Stator BP	LP stator	Niederdruckstator											1										103882	
27	Idem 20	Idem 20	Ebenso 20	1/2	1/2	1/2	1/2	1/2	1/2	1/2	1/2	1/2	1/2				1/2	1/2	1/2	1/2	1/2	1/2	1/2	●	
28	Idem 21	Idem 21	Ebenso 21	1/4	1/4	1/4	1/4	1/4	1/4	1/4	1/4	1/4	1/4	1/2	1/2		1/4	1/4	1/4	1/4	1/4	1/4	1/4	●	
29	Flasque médian	Central plate	Zwischenflansche	1	1	1	1	1			1	1	1											103408S	
29	Flasque médian	Central plate	Zwischenflansche														1	1	1	1	1	1	1	103410S	
29	Flasque médian	Central plate	Zwischenflansche							1														105639	
30	Idem 21	Idem 21	Ebenso 21	1/4	1/4	1/4	1/4	1/4	1/4	1/4	1/4	1/4				1/4	1/4	1/4	1/4	1/4	1/4	1/4	1/4	●	
31	Rotor HP	HP rotor	Hochdruckrotor							1														065853S	
31	Rotor HP	HP rotor	Hochdruckrotor					1			1	1	1											065852S	
31	Rotor HP	HP rotor	Hochdruckrotor	1	1	1	1																	103417S	
31	Rotor HP	HP rotor	Hochdruckrotor														1	1	1	1	1	1	1	102854S	
32	Idem 24	Idem 24	Ebenso 24	2/4	2/6	2/8	2/8	2/4	2/4	2/6	2/8	2/8				2/6	2/8	2/8	2/4	2/6	2/8	2/8	2/8	●○	
33	Palette HP	HP vane	Hochdruckschieber	2	2	2	2	2	2	2	2	2				2	2	2	2	2	2	2	2	●○*	
34	Stator HP	HP stator	Hochdruckstator							1														065722S	
34	Stator HP	HP stator	Hochdruckstator	1	1	1	1	1			1	1	1			1	1	1	1	1	1	1	1	103409S	
35	Ressort clapet anti-retour	Spring of the antisuck-back	Federrückschlagventil	1	1	1	1	1	1	1	1	1	1			1	1	1	1	1	1	1	1	■	
36	Clapet anti-retour	Antisuck-back device	Rückschlagventil	1	1	1	1	1	1	1	1	1	1			1	1	1	1	1	1	1	1	065798	
37	Idem 21	Idem 21	Ebenso 21	1/4	1/4	1/4	1/4	1/4	1/4	1/4	1/4	1/4				1/4	1/4	1/4	1/4	1/4	1/4	1/4	1/4	●	
43	Gicleur	Injector	Düse																					105091	

● Lot de joints / Seal kit / Dichtungssatz

■ Kit de révision / Overhaul kit / Revision kit

⊕ Lot visserie / Screw kit / Schraubensatz

○ Lot palettes / Vane kit / Schieberratz

* Kit joint avant / Front seal kit / Dichtungssatz

* sauf C2 / except C2 / ausgenommen C2

Plan du bloc fonctionnel (avec stator flasqué) (C)
Pumping module drawing (with flanged stator) (C)
Gesamtplan: Funktionsblock mit Stator-Monoblock (C)

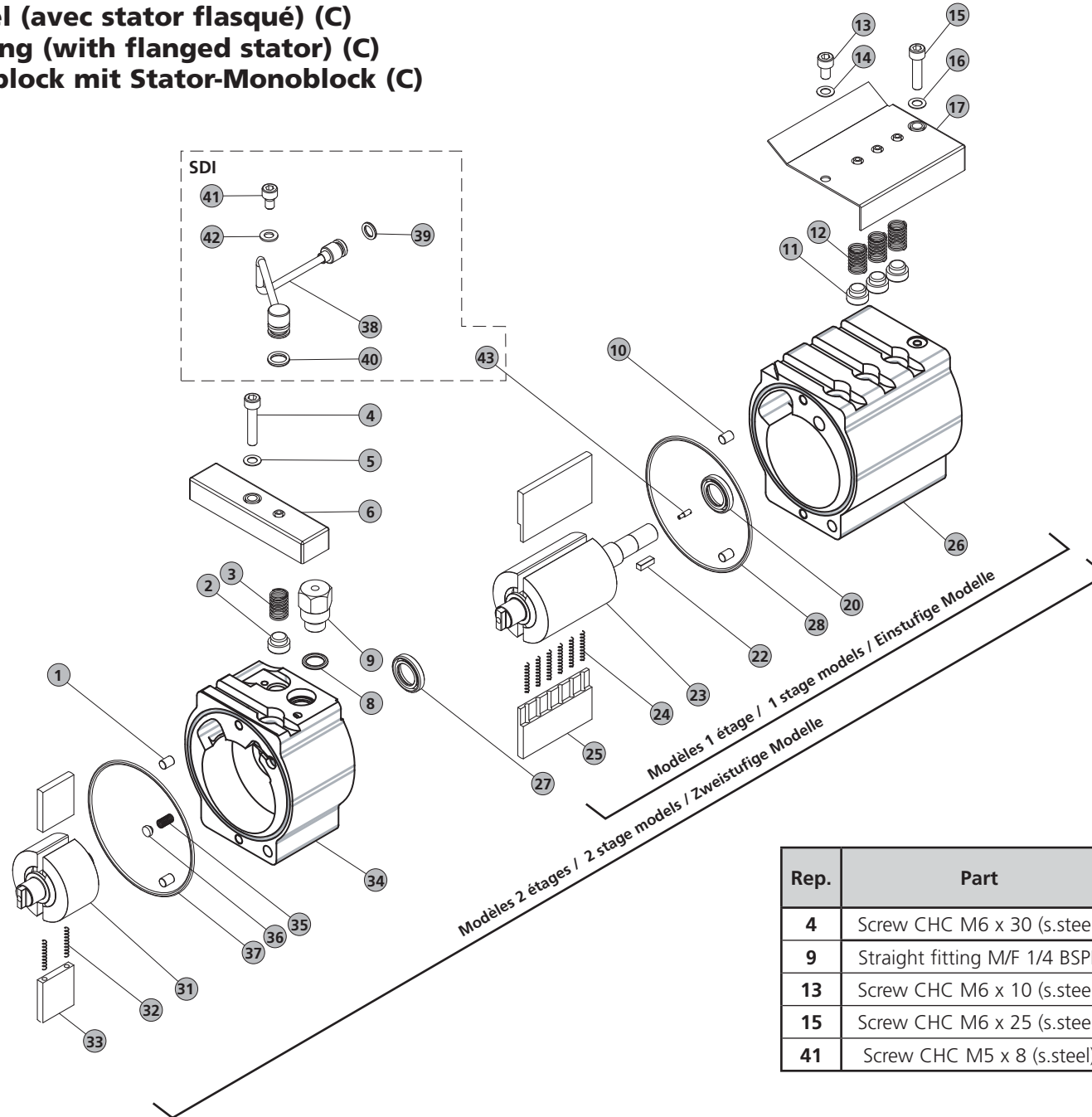

Rep.	Part	Clamping torque (N·m)
4	Screw CHC M6 x 30 (s.steel)	9.0
9	Straight fitting M/F 1/4 BSPP	18.0
13	Screw CHC M6 x 10 (s.steel)	9.0
15	Screw CHC M6 x 25 (s.steel)	9.0
41	Screw CHC M5 x 8 (s.steel)	7.0

Nomenclature du bloc fonctionnel (avec stator flasqué) (C)

Pumping module list (with flanged stator) (C)

Nomenklatur: Funktionsblock mit Stator-Monoblock (C)

REP	DÉSIGNATION	SPECIFICATION	BENENNUNG	Types/model																REF. P/N Bestell. Nr				
				2005 I	2010 I	2015 I	2021 I	1015 I	2005 SD	2005 SDI	2010 SD	2015 SD	2021 SD	1005 SD	1015 SD	2010 C2	2015 C2	2021 C2	2005 C1		2010 C1	2015 C1	2021 C1	
1	Goupille D6 LG8	Centering pin D6 LG8	Zentrierstift	1/4	1/4	1/4	1/5		1/5	1/5	1/5	1/4	1/4			1/4	1/4	1/4	1/4	1/4	1/5	1/5	■	
2	Soupape	Valve	Auslassventil	1	1/3	1/4	1/4		1	1	1/3	1/4	1/4			1/3	1/4	1/4	1/2	1/3	1/4	1/4	●	
3	Ressort de soupape	Valve spring	Ventilfeder	1	1/3	1/4	1/4		1	1	1/3	1/4	1/4			1/3	1/4	1/4	1/2	1/3	1/4	1/4	■	
4	Vis CHC M6 x 30	Screw CHC M6 x 30	Schraube CHC M6 x 30	1	1	1	1		1	1	1	1	1	1		1	1	1	1	1	1	1	✚	
4	Vis CHC M6 x 10	Screw CHC M6 x 10	Schraube CHC M6 x 10																				✚	
5	Rondelle	Washer	Unterlegscheibe	1	1/2	1/2	1/2		1	1	1/2	1/2	1/2			1/2	1/2	1/2	1	1/2	1/2	1/2	✚	
6	Capot de soupape HP	Valve cover HP	Ventilgehäusedeckel HD	1	1	1	1		1	1	1	1	1	1	1	1	1	1	1	1	1	1	A332166	
8	Joint torique c 2,7 - d 10,5 - Bague R9	O-ring c 2.7 - d 10.5 - Ring R9	Dichtung c 2,7 - d 10,5 - Ring R9	1	1	1	1		1	1	1	1	1			1	1	1	1	1	1	1	●	
9	Bouchon support capot	Cover holder	Gehäusedeckelhalter	1	1	1	1		1	1	1	1	1			1	1	1	1	1	1	1	103544	
10	Idem 1	Idem 1	Ebenso 1	1/4	1/4	1/4	1/4		1/4	1/4	1/4	1/4	1/4	1/2	1/2	1/4	1/4	1/4	1/4	1/4	1/4	1/4	1/4	■
11	Idem 2	Idem 2	Ebenso 2		2/3	3/4	3/4	3			2/3	3/4	3/4	1	3	2/3	3/4	3/4	1/2	2/3	3/4	3/4	●	
12	Idem 3	Idem 3	Ebenso 3		2/3	3/4	3/4	3			2/3	3/4	3/4	1	3	2/3	3/4	3/4	1/2	2/3	3/4	3/4	■	
13	Vis CHC M6 x 10	Screw CHC M6 x 10	Schraube CHC M6 x 10		1	1	1				1	1	1	1	1	1	1	1	1	1	1	1	✚	
14	Rondelle	Washer	Unterlegscheibe		1/2	1/2	1/2				1/2	1/2	1/2	1/2	1/2	1/2	1/2	1/2	1/2	1/2	1/2	1/2	✚	
15	Vis CHC M6 x 25	Screw CHC M6 x 25	Schraube CHC M6 x 25		1	1	1	2			1	1	1	2	2	1	1	1	1	1	1	1	✚	
16	Rondelle	Washer	Unterlegscheibe		1/3	1/3	1/3	2/2			1/3	1/3	1/3	1/2	2/2	1/3	1/3	1/3	1/3	1/3	1/3	1/3	✚	
17	Capot de soupape BP	Valve cover LP	Ventilgehäusedeckel ND		1						1					1					1		A332176	
17	Capot de soupape BP	Valve cover LP	Ventilgehäusedeckel ND			1						1					1				1		A332266	
17	Capot de soupape BP	Valve cover LP	Ventilgehäusedeckel ND				1						1					1				1	A332175	
17	Capot de soupape	Valve cover	Ventilgehäusedeckel											1									A332900	
17	Capot de soupape	Valve cover	Ventilgehäusedeckel					1															A216503	
20	Joint à lèvres 15 x 25,5 x 4,6	Shaft seal 15 x 25.5 x 4.6	Lippendichtung 15 x 25,5 x 4,6	1/2	1/2	1/2	1/2	1	1/2	1/2	1/2	1/2	1/2	1	1	1/2	1/2	1/2	1/2	1/2	1/2	1/2	1/2	●
22	Clavette Parallèle A4 x 4 x 12	Shaft key A4 x 4 x 12	Nutenstein A4 x 4 x 12	1	1	1	1	1	1	1	1	1	1	1	1	1	1	1	1	1	1	1	■	
23	Rotor BP	LP rotor	Niederdruckrotor	1					1	1													065745S	
23	Rotor BP	LP rotor	Niederdruckrotor		1						1												065749S	
23	Rotor BP	LP rotor	Niederdruckrotor			1						1											065750S	
23	Rotor BP	LP rotor	Niederdruckrotor				1						1										065751S	
23	Rotor	Rotor	Rotor											1									103880S	
23	Rotor	Rotor	Rotor					1							1								103569S	
23	Rotor BP	LP rotor	Niederdruckrotor													1					1		065801S	
23	Rotor BP	LP rotor	Niederdruckrotor														1					1	065802S	
23	Rotor BP	LP rotor	Niederdruckrotor															1				1	065803S	
23	Rotor BP	LP rotor	Niederdruckrotor																1				065601S	
24	Ressort de palette	Vane spring	Schieberfeder	2/4	4/6	6/8	6/8	6	2/4	2/4	4/6	6/8	6/8	2	6	4/6	6/8	6/8	2/4	4/6	6/8	6/8	■○	
25	Palette BP	LP vane	Niederdruckschieber	2	2	2	2	2	2	2	2	2	2	2	2	2	2	2	2	2	2	2	2	■○
26	Stator BP	LP stator	Niederdruckstator	1					1	1													A006001S	
26	Stator BP	LP stator	Niederdruckstator		1						1												A006000S	
26	Stator BP	LP stator	Niederdruckstator			1						1											A005999S	
26	Stator BP	LP stator	Niederdruckstator				1						1										A005997S	
26	Stator	Stator	Stator											1									A006465S	

● Lot de joints / Seal kit / Dichtungssatz

■ Kit de révision / Overhaul kit / Revision kit

✚ Lot visserie / Screw kit / Schraubensatz

○ Lot palettes / Vane kit / Schiebessatz

* Kit joint avant / Front seal kit / Dichtungssatz

Plan du bloc fonctionnel (avec stator flasqué) (C)
Pumping module drawing (with flanged stator) (C)
Gesamtplan: Funktionsblock mit Stator-Monoblock (C)

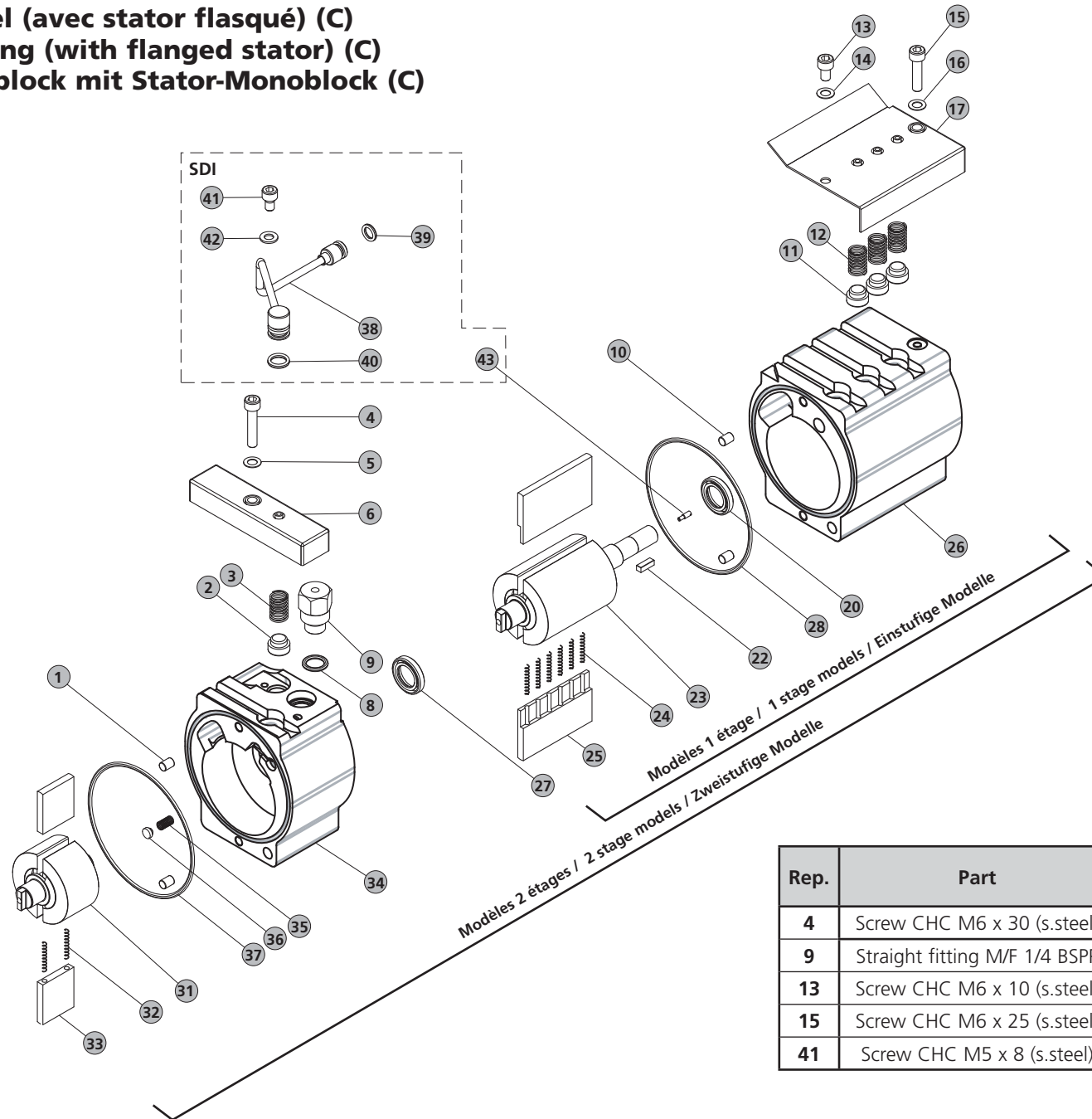

Rep.	Part	Clamping torque (N·m)
4	Screw CHC M6 x 30 (s.steel)	9.0
9	Straight fitting M/F 1/4 BSPP	18.0
13	Screw CHC M6 x 10 (s.steel)	9.0
15	Screw CHC M6 x 25 (s.steel)	9.0
41	Screw CHC M5 x 8 (s.steel)	7.0

Plan du système de lubrification pompe à huile (A)
Oil pump system drawing (A)
Ölpumpsystem Gesamtplan (A)

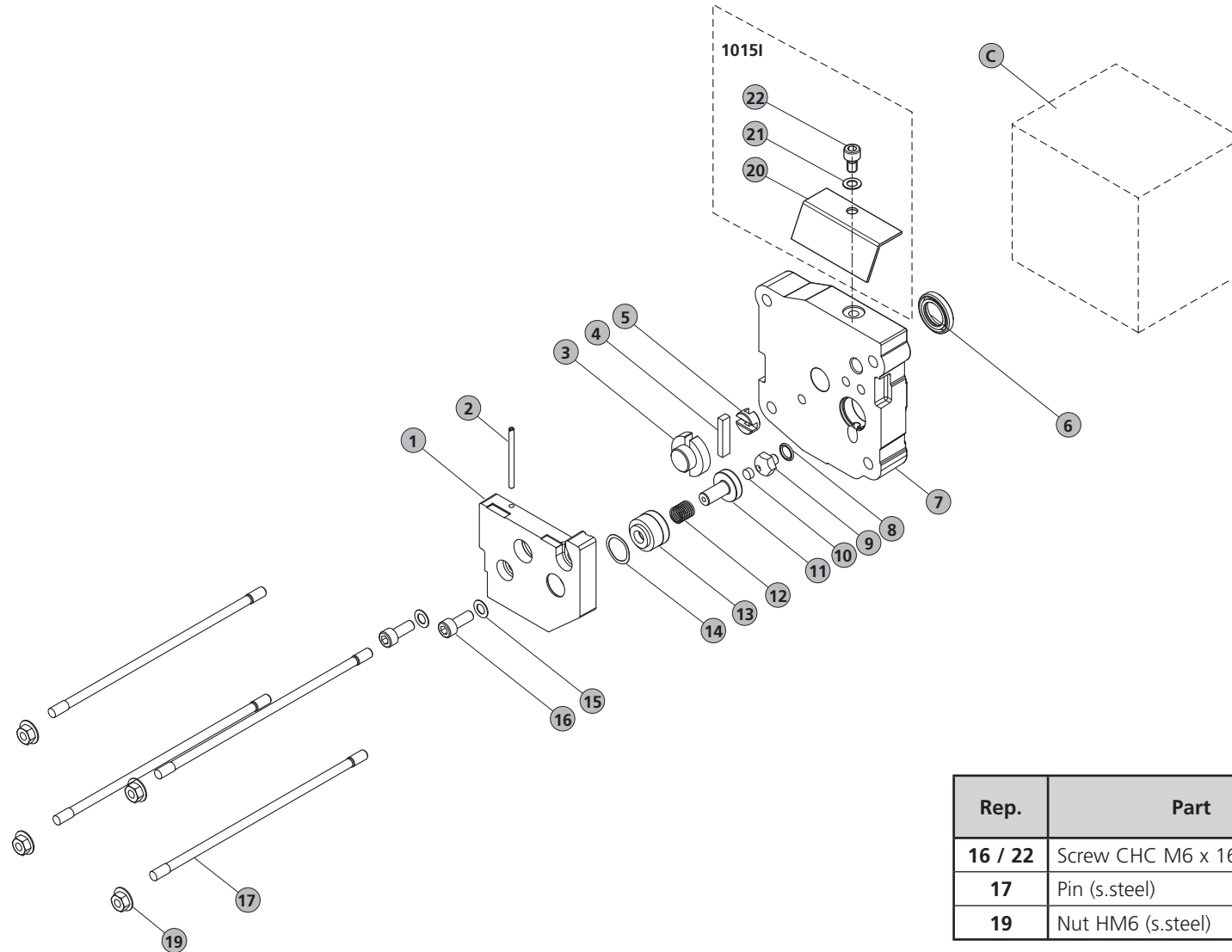

Rep.	Part	Clamping torque (N·m)
16 / 22	Screw CHC M6 x 16 (s.steel)	9.0
17	Pin (s.steel)	14.0
19	Nut HM6 (s.steel)	9.5

Plan du système de lubrification levier moulinet (B)
Oil system drawing (B)
Flügenrech-Ölsystem Gesamtplan (B)

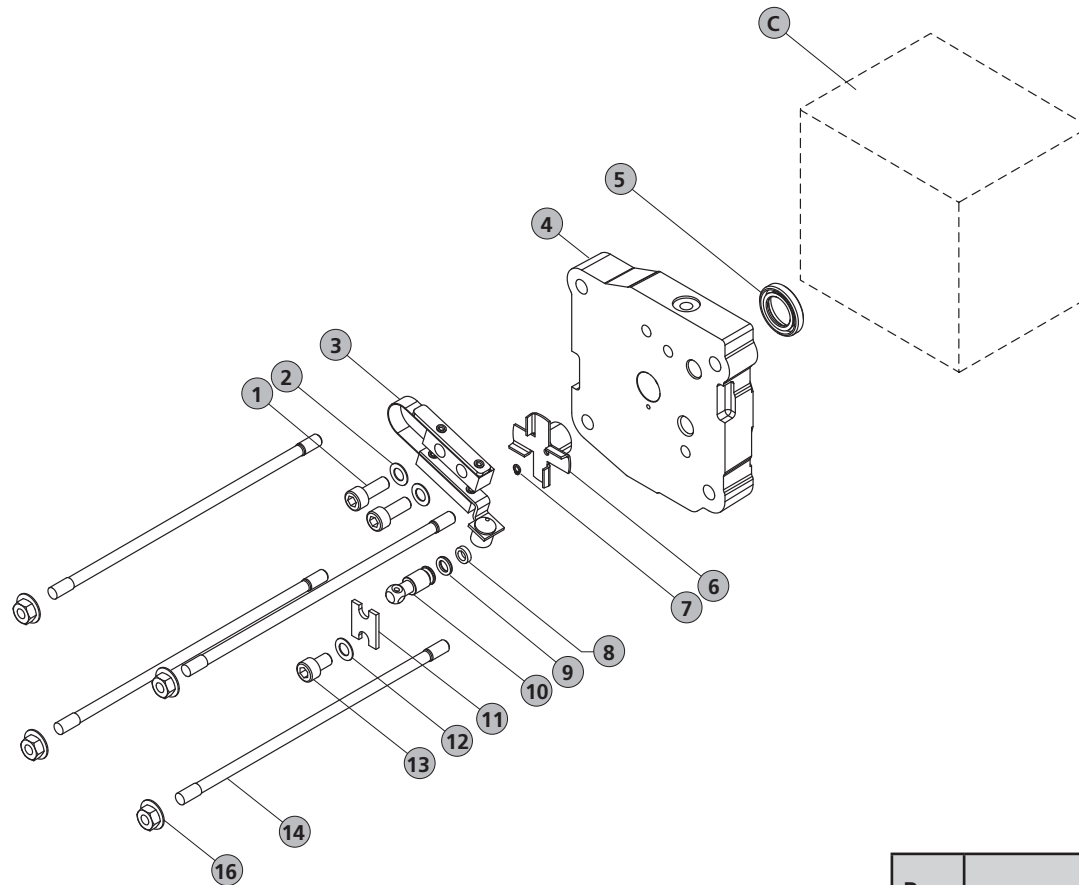

Rep.	Part	Clamping torque (N·m)
1	Screw CHC M6 x 16 (s.steel)	9.0
13	Screw CHC M6 x 10 (s.steel)	9.0
14	Pin (s.steel)	14.0
16	Nut (s.steel)	9.5

Nomenclature du système de lubrification levier moulinet / Oilsystem part list / Flügenrechölssystem Nomenklatur

REP	DÉSIGNATION	SPECIFICATION	BENENNUNG	Types/model						REF. P/N Bestell. Nr
				2005 SD	2005 SDI	2010 SD	2015 SD	2021 SD	1005 SD	
1	Vis CHC M6 x 16	Screw CHC M6 x 16	Schraube CHC M6 x 16	2	2	2	2	2	2	✚
2	Rondelle	Washer	Unterlegscheibe	2/3	2/3	2/3	2/3	2/3	2/3	✚
3	Levier oscillant	Equipped lever	Hebel	1	1	1	1	1	1	■
4	Flasque arrière	Rear plate	Hintererflansche	1	1	1	1	1	1	1034855
5	Joint à lèvres 15 x 25,5 x 4,6	Shaft seal 15 x 25.5 x 4.6	Lippendichtung 15 x 25,5 x 4,6	1	1	1	1	1	1	●
6	Came moulinet	Impeller	Flügenrech	1	1	1	1	1	1	052721
7	Bague d'arrêt	Clips	Sprengring	1	1	1	1	1	1	■
8	Rondelle	Washer	Unterlegscheibe	1		1	1	1		052758
8	Gicleur	Jet	Düse						1	102910
8	Gicleur	Jet	Düse		1					103314
9	Joint torique c 1,9 - d 5,7 - Bague R5	O-ring c 1.9 - d 5.7 - Ring R5	Dichtung c 1,9 - d 5,7 - Ring R5	1	1	1	1	1	1	●
10	Siège de clapet	Seat	Ventilsitz	1	1	1	1	1	1	052718
11	Bride	Flange	Klammer	1	1	1	1	1	1	052569
12	Idem 2	Idem 2	Ebenso 2	1/3	1/3	1/3	1/3	1/3	1/3	✚
13	Vis CHC M6 x 10	Screw CHC M6 x 10	Schraube CHC M6 x 10	1	1	1	1	1	1	✚
14	Goujon M6-129 / 19	Pin M6-129 / 19	Stift M6-129 / 19	4	4					102855
14	Goujon M6-142 / 12	Pin M6-142 / 12	Stift M6-142 / 12			4				065806
14	Goujon M6-164 / 12	Pin M6-164 / 12	Stift M6-164 / 12				4			065805
14	Goujon M6-187 / 12	Pin M6-187 / 12	Stift M6-187 / 12					4		065804
14	Goujon M6-72 / 19	Pin M6-72 / 19	Stift M6-72 / 19						4	065636
14	Goujon M6-84 / 12	Pin M6-84 / 12	Stift M6-84 / 12							103524
16	Ecrou à embase HM6	Shouldered nut HM6	Schraubenmutter HM6	4	4	4	4	4	4	✚

● Lot de joints / Seal kit / Dichtungssatz

■ Kit de révision / Overhaul kit / Revision kit

✚ Lot visserie / Screw kit / Schraubensatz

Sous-ensemble B / Subassembly B / Gesamtplan B

Plan ensemble motorisation (M)
Motor assembly drawing (M)
Motor Gesamtplan (M)

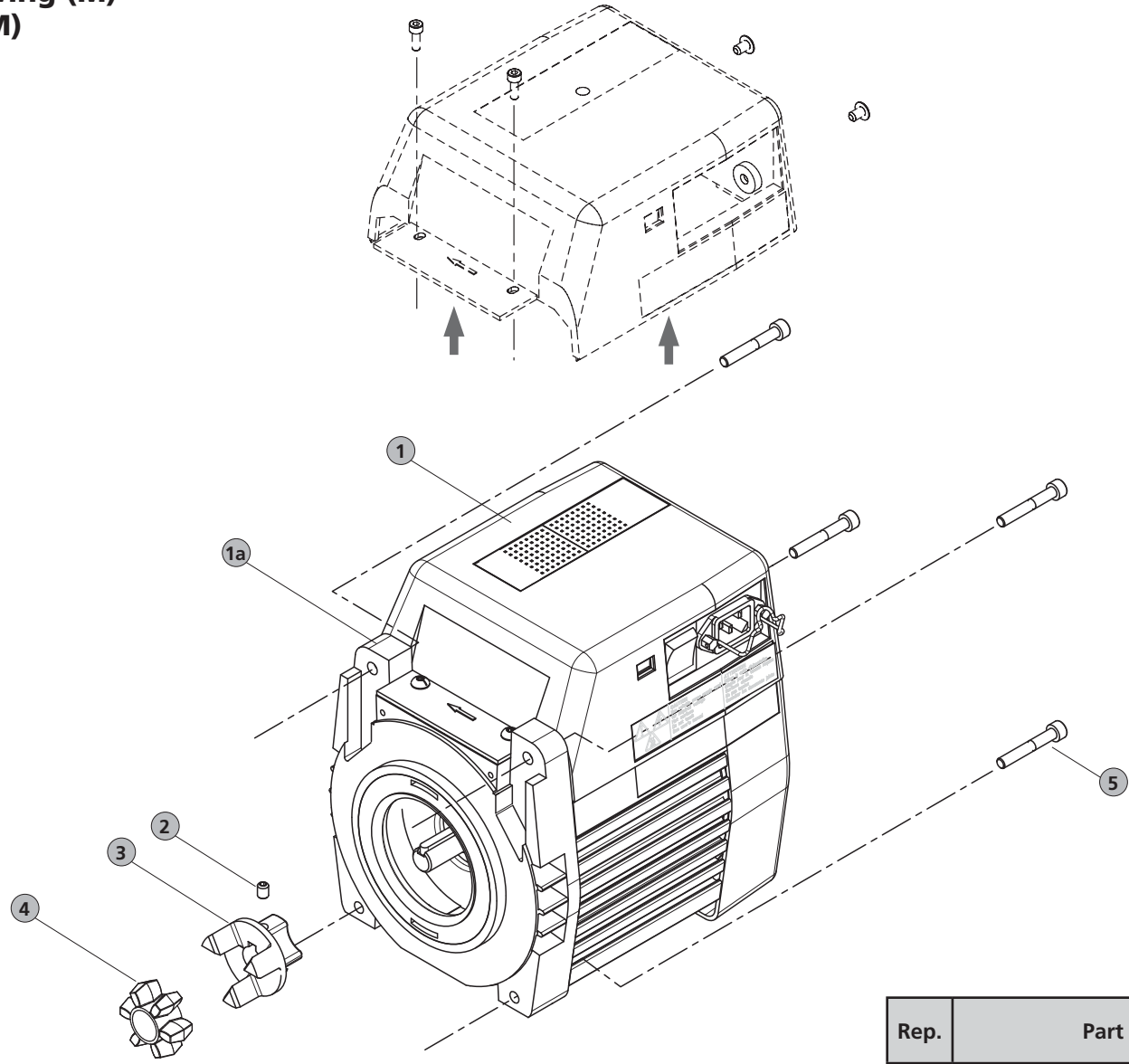

Rep.	Part	Clamping torque (N·m)
5	Screw CHc M6 x 40 (s.steel)	9.5
2	Screw Hc M6 x 8.8 (s.steel)	2.5

Nomenclature ensemble motorisation (M) / Motor assembly part list (M) / Motor Gesamtheit Nomenklatur (M)

MOTEUR UNIVERSEL / UNIVERSAL MOTOR / UNIVERSELLE MOTOR					
REP	DÉSIGNATION	SPECIFICATION	BENENNUNG	Qty	REF. P/N Bestell. Nr
1	Moteur monophasé standard avec interrupteur*	Single phase motor with on/off switch*	Wechselstrommotor* mit Schalter	1	108694
1	Moteur monophasé sans interrupteur*	Single phase motor without switch*	Wechselstrommotor* ohne Schalter*	1	108698
1	Moteur triphasé standard	Three-phase motor	Drehstrommotor	1	108695
1	Moteur monophasé Japon, basse tension, avec interrupteur*	Japanese single phase motor, LV, with on/off switch*	Niederspannung-Japan-Wechselstrommotor* mit Schalter	1	108802S
1a	Kit d'adaptation pour moteur bride CEI (bride CEI + vis + 1/2 manchon + intercalaire)	CEI flange motor coupling kit (CEI flange + screw + motor side coupling+ plastic coupling)	CEI Klammer Motorflanschssatz (Klammer Motorflanschssatz + Schraube + Kupplugshälfte + Kuppelungsstern)	1	104558S
2	Vis Hc M6 x 8,8	Screw Hc M6 x 8.8	Schraube Hc M6 x 8,8	1	❖
3	1/2 Manchon moteur	Motor side coupling	Kupplungshälfte	1	065742
4	Intercalaire	Plastic coupling	Kupplungstern	1	■
5	Vis CHc M6 x 40	Screw CHc M6 x 40	Schraube CHc M6 x 40	4	❖

* Moteur livré sans câble mais équipé avec 2+3+4

* Delivered without cable but equipped with 2+3+4

* ohne Netzkabel aber mit 2+3+4 einrichtet

● Lot de joints / Seal kit / Dichtungssatz

■ Kit de révision / Overhaul kit / Revision kit

❖ Lot visserie / Screw kit / Schraubensatz

CÂBLE ÉLECTRIQUE POUR MOTEUR MONOPHASÉ / ELECTRICAL CABLE FOR SINGLE PHASE MOTOR / NETZKABEL FÜR WECHSELSTROMMOTOR (L = 2M)			
DÉSIGNATION	SPECIFICATION	BENENNUNG	REF. P/N Bestell. Nr
USA (Basse tension)	USA (Low voltage)	Netzkabel (Niederspannung) (USA)	103567
USA (Haute tension)	USA (High voltage)	Netzkabel (Hochspannung) (USA)	103898
EUROPE	EUROPE	Netzkabel (EUROPA)	103566
JAPON (Basse tension)	JAPAN (Basse tension)	Netzkabel (Niederspannung) (JAPAN)	103567
JAPON (Haute tension)	JAPAN (Haute tension)	Netzkabel (Hochspannung) (JAPAN)	104559
ROYAUME UNI	UNITED KINGDOM	Netzkabel (GB)	104411
SUISSE (Coudé)	SWITZERLAND (elbow)	Netzkabel (SCHWEIZ)	A459212

Plan du système bulleur
Bubbler system drawing
Bubbler system Gesamtplan

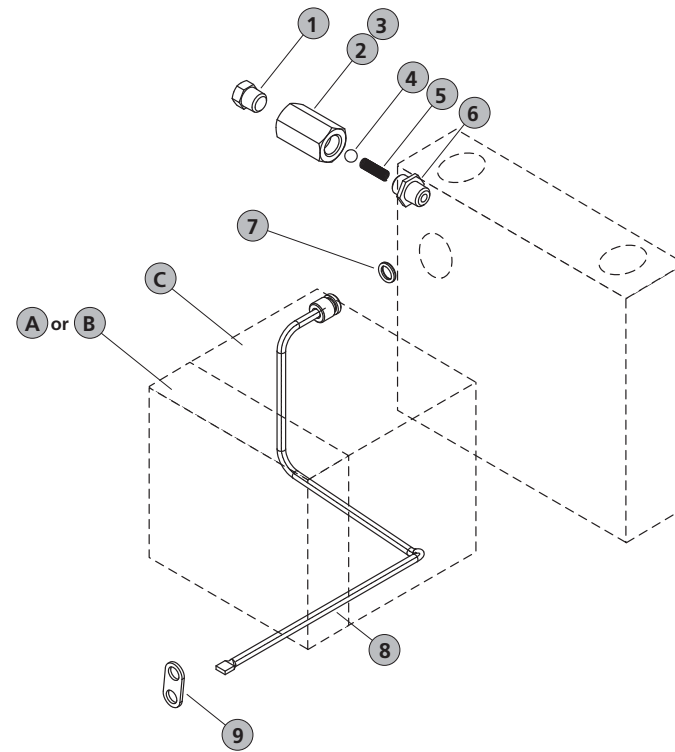

Nomenclature du système bulleur / Bubbler system part list / Bubbler system Nomenklatur

REP	DÉSIGNATION	SPECIFICATION	BENENNUNG	Types/model			REF. P/N Bestell. Nr
				2010 C2	2015 C2	2021 C2	
1	Bouchon 1/8 NPT	Plug 1/8 NPT	Blindstopfen 1/8 NPT	1	1	1	082926
2	Manchon	Coupling	Kupplung	1	1	1	065866
3	Ruban teflon	Teflon band	Teflon band	1	1	1	060975
4	Bille inox 18/8 d. 5,8	Ball 18/8 d. 5.8	Kugel 18/8 d, 5,8	1	1	1	087593
5	Ressort	Spring	Feder	1	1	1	065149
6	Raccord G 1/8 -1/8 NPT	Connector G 1/8 -1/8 NPT	Verbindungselement	1	1	1	065867
7	Joint torique c 1,9 - d 7,2	O-ring c 1.9 - d 7.2	Dichtung c 1,9 - d 7,2	1	1	1	●
8	Bulleur	Bubbler	Bubler	1	1		065836
8	Bulleur	Bubbler	Bubler			1	065835
9	Attache tube	Tube fastener	Rohrbefestigung	1	1	1	065835

● Lot de joints / Seal kit / Dichtungssatz

■ Kit de révision / Overhaul kit / Revision kit

⊕ Lot visserie / Screw kit / Schraubensatz

Remplacement des pièces du bloc fonctionnel non flasqué Pumping module (with no flanged stator) spare parts Pumpenblock (mit Stator und Flanschen) Unterhaltung Teile

Modèles 2 étages / 2 stage models / Zweistufige Modelle

Modèle Model Modelle	Bloc fonctionnel / Pumping module / Pumpenblock				
	non flasqué / no flanged mit Stator und Flanschen		flasqué / flanged mit Stator-Monoblock		
	Pièce à remplacer Part to be replaced Zu ersetzender Teil	Référence P/N Bestell. Nr	Référence P/N Bestell. Nr		
2005 C1	Flasque avant (C) Front plate Einrichtet vorderer Flansche	19 103396S	A006037S	-	
2010 C1 / C2			A006038S	A332176	
2015 C1 / C2			A006039S	A332266	
2021 C1 / C2			A006040S	A332175	
2005 I / SD / SDI	Flasque avant (standard) Front plate Einrichtet vorderer Flansche	19 103401S	A006001S	-	
2010 I / SD			A006000S	A332176	
2015 I / SD			A005999S	A332266	
2021 I / SD			A005997S	A332175	
2005 C1	Flasque médian (C) Central plate Zwischenflansche	29 103410S	A006042S	+ 6 A332166	
2010 C1 / C2			A005996S		
2015 C1 / C2			A006496S		
2021 C1 / C2			A006496S		
2005 I / SD	Flasque médian (standard) Central plate Zwischenflansche	29 103408S	A005996S	+ 6 A332166	
2010 I / SD			A006496S		
2015 I / SD			A006496S		
2021 I / SD			A006496S		
2005 SDI *		105639	A006496S		
2005 C1	Stator HP HP stator Hochdruckstator	34 103409S	A006042S	+ 6 A332166	
2010 C1 / C2			A005996S		
2015 C1 / C2			A006496S		
2021 C1 / C2			A006496S		
2005 I / SD			065722S		A006496S
2010 I / SD					A006496S
2015 I / SD			A006496S		
2021 I / SD			A006496S		
2005 SDI *			A006496S		
2005 I / SD / SDI	Stator BP LP stator Niederdruckstator	103507S	A006001S	-	
2005 C1		103512S	A006037S	+ 17 A332176	
2010 I / SD		103510S	A006000S		
2010 C1 / C2		103510S	A006038S		
2015 I / SD		103393S	A005999S		
2015 C1 / C2			A006039S		
2021 I / SD			A005997S		
2021 C1 / C2			A006040S		

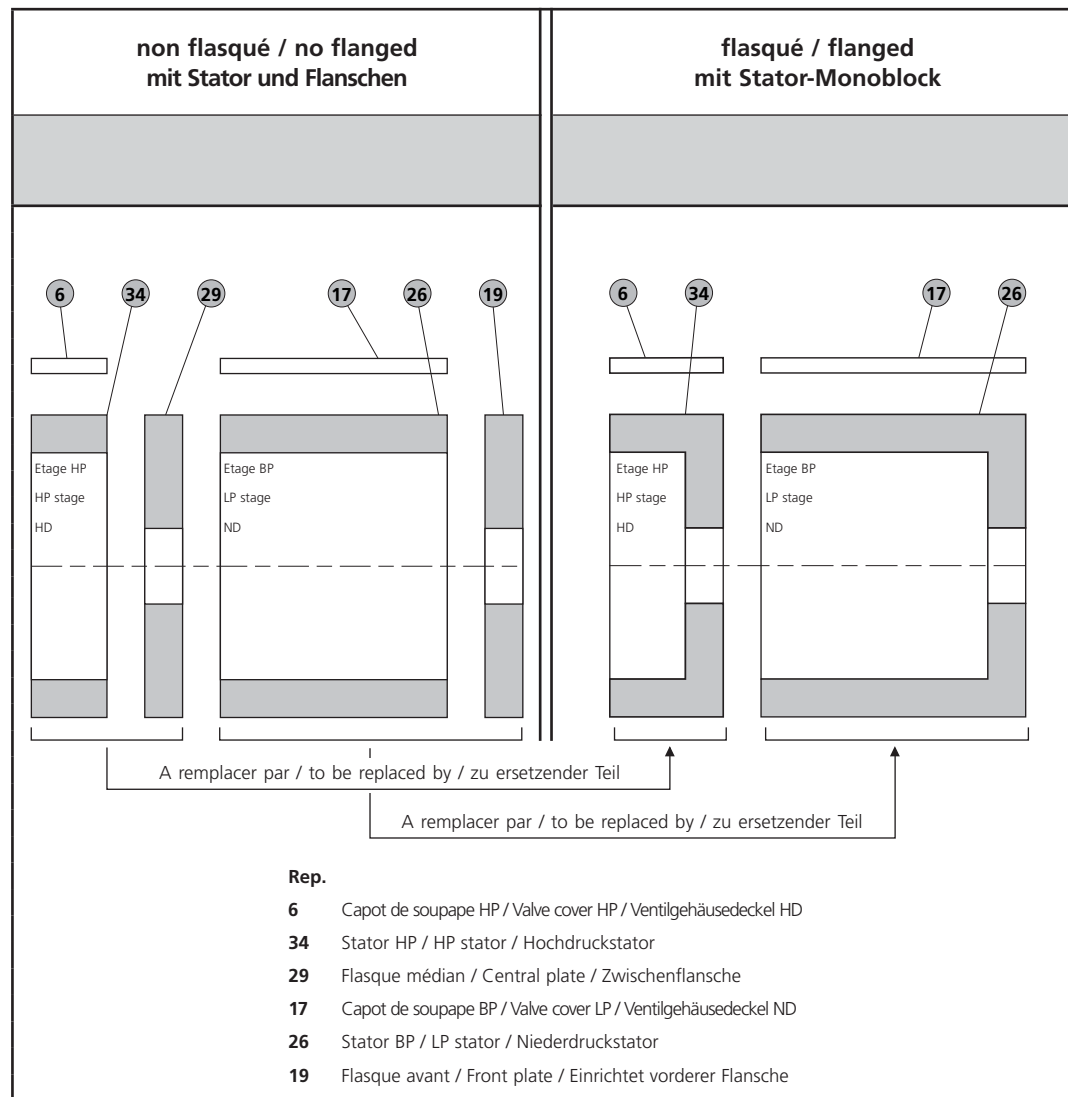

* Dans ce cas, changer également le rotor HP (31) (voir nomenclature du bloc fonctionnel avec stator flasqué (C) (page N-13)) et utiliser le kit de révision SDI (voir page 47).

* In this case, replace also HP rotor (31) (refer to pumping module with flanged stator (C) (page N-13)) and use a SDI Overhaul kit (see page 47).

* In diesem Fall ebenfalls den Hochdruckrotor (31) auswechseln (siehe Nomenklatur des Funktionsblocks mit geflanschem Stator (siehe Seite N - 13)) und SDI-Revision kit verwenden (siehe Seite 47).

Remplacement des pièces du bloc fonctionnel non flasqué Pumping module (with no flanged stator) spare parts Pumpenblock (mit Stator und Flanschen) Unterhaltung Teile

Modèles 2 étages / 2 stage models / Zweistufige Modelle

Modèle Model Modelle	Bloc fonctionnel / Pumping module / Pumpenblock								
	non flasqué / no flanged mit Stator und Flanschen		flasqué / flanged mit Stator-Monoblock						
	Pièce à remplacer Part to be replaced Zu ersetzender Teil	Référence P/N Bestell. Nr	Référence P/N Bestell. Nr						
2005 C1	Capot de soupape HP Valve cover HP Ventilgehäusedeckel HD	6	103521	34	A006042S	+	6	A332166	
2010 C1 / C2					A005996S				
2015 C1 / C2					A006496S				
2021 C1 / C2					26	A006001S	+	17	
2005 I / SD						A006037S			
2010 I / SD						A006000S			A332176
2015 I / SD		A006038S	A005999S	A332266					
2021 I / SD		A006039S	A005997S	A332175					
2005 SDI*		103394	A006040S						
2005 I / SD / SDI	Capot de soupape BP Valve cover LP	-							
2005 C1	Ventilgehäusedeckel ND	17	103523	26	A006001S	+	17		
2010 I / SD					A006037S				
2010 C1 / C2					A006000S			A332176	
2015 I / SD					A006038S			A005999S	A332266
2015 C1 / C2					A006039S			A005997S	A332175
2021 I / SD					A005997S				
2021 C1 / C2		103394	A006040S						

- * Dans ce cas, changer également le rotor HP (31) (voir nomenclature du bloc fonctionnel avec stator flasqué (C) (page N-13)) et utiliser le lot de maintenance SDI (voir page 47).
- * In this case, replace also HP rotor (31) (refer to pumping module with flanged stator (C) (page N-13)) and use a SDI Overhaul kit (see page 47).
- * In diesem Fall ebenfalls den Hochdruckrotor (31) auswechseln (siehe Nomenklatur des Funktionsblocks mit geflanschem Stator (siehe Seite N - 13)) und SDI-Revision kit verwenden (siehe Seite 47).

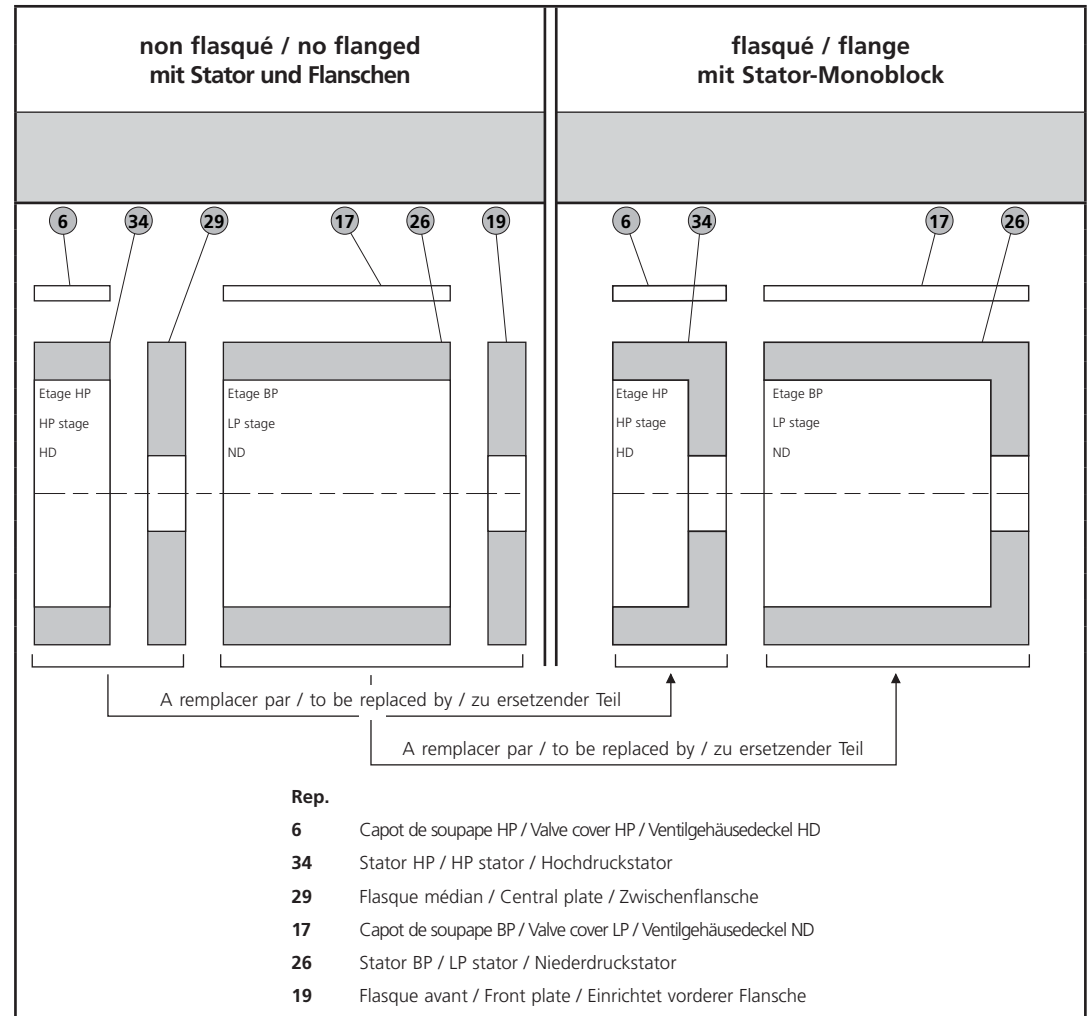

Remplacement des pièces, bloc fonctionnel non flasqué Pumping module (with no flanged stator) spare parts Pumpenblock (mit Stator und Flanschen) Unterhaltung Teile

Modèles 1 étage / 1 stage models / Einstufige Modelle

Modèle Model Modelle	Bloc fonctionnel / Pumping module / Pumpenblock			
	non flasqué / no flanged mit Stator und Flanschen		flasqué / flanged mit Stator-Monoblock	
	Pièce à remplacer Part to be replaced Zu ersetzender Teil	Référence P/N Bestell. Nr	Référence P/N Bestell. Nr	
1005 SD	Flasque avant (standard) Front plate	19 103401S	26 A006465S	+ 6 A332166
1015 SD	Einrichtet vorderer Flansche		26 A006466S	
1005 SD	Stator BP LP stator	26 103409S	26 A006465S	+ 6 A332166
1015 SD	Niederdruckstator		26 A006466S	
1005 SD	Capot de soupape BP Valve cover LP	6 103521	26 A006465S	+ 6 A332166
1015 SD	Ventilgehäusedeckel ND		26 A006466S	
Rep. 6 Capot de soupape / Valve cover / Ventilgehäusedeckel 26 Stator BP / LP stator / Niederdruckstator 19 Flasque avant / Front plate / Einrichtet vorderer Flansche				

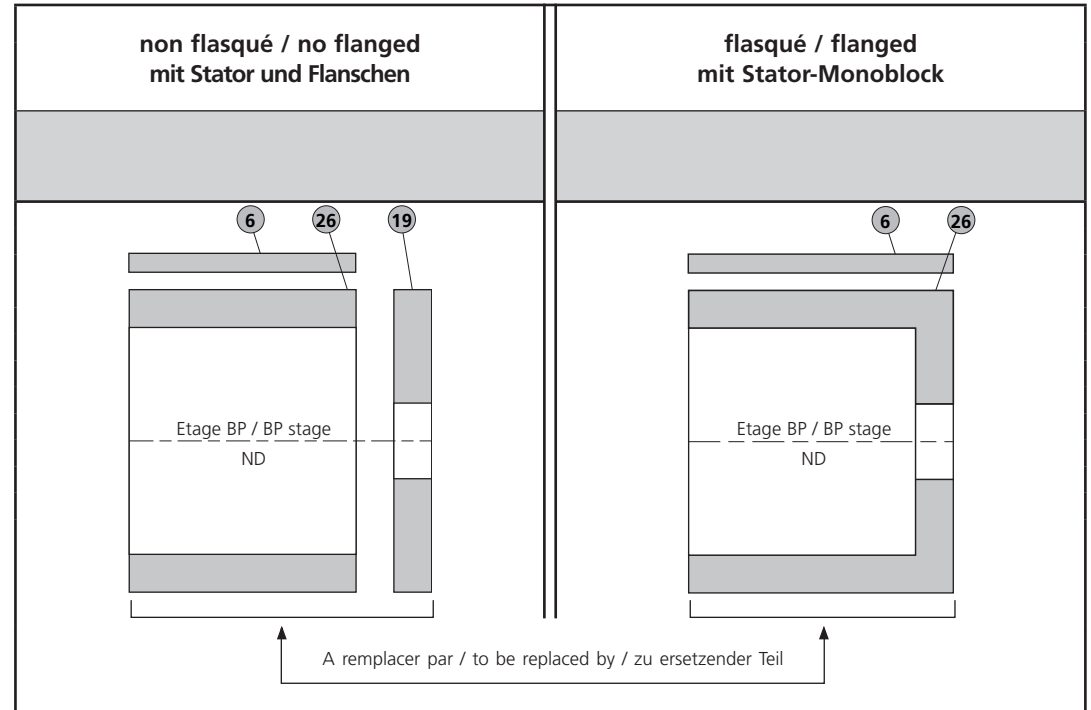

VACUUM SOLUTIONS FROM A SINGLE SOURCE

Pfeiffer Vacuum stands for innovative and custom vacuum solutions worldwide, technological perfection, competent advice and reliable service.

COMPLETE RANGE OF PRODUCTS

From a single component to complex systems:

We are the only supplier of vacuum technology that provides a complete product portfolio.

COMPETENCE IN THEORY AND PRACTICE

Benefit from our know-how and our portfolio of training opportunities!

We support you with your plant layout and provide first-class on-site service worldwide.

Ed 04 - Date 2017/04 - P/N: 103275MEN

* 103275 *

Are you looking for a
perfect vacuum solution?
Please contact us:

Pfeiffer Vacuum GmbH
Headquarters • Germany
T +49 6441 802-0
info@pfeiffer-vacuum.de

www.pfeiffer-vacuum.com

